

# **Vallejo Waterfront Planned Development Master Plan and Design Guidelines**

*Vallejo, California*



*March 13, 2007  
Amended June 2013  
Amended August 2013*





***Vallejo Waterfront  
Planned Development Master Plan and  
Design Guidelines***





# Table of Contents

PREAMBLE ..... I

PLANNED DEVELOPMENT MASTER PLAN ..... PDMP-I

- 1. Introduction ..... PDMP-I
  - 1.1 Plan Area and Setting ..... PDMP-I
  - 1.2 Planning Process ..... PDMP-3
  - 1.3 Project Objectives ..... PDMP-4
  - 1.4 Planning Goals ..... PDMP-5
    - 1.4.1 Planning Goals for Private Development ..... PDMP-5
    - 1.4.2 Planning Goals for Public Spaces ..... PDMP-5
  - 1.5 Vision Statement ..... PDMP-6
- 2. PDMP Summary ..... PDMP-6
- 3. Overriding PDMP Goals and Policies ..... PDMP-7
  - 3.1 Pedestrian-Oriented Mixed Use District ..... PDMP-7
  - 3.2 Integrated Urban Fabric ..... PDMP-8
  - 3.3 Visual Access and Orientation ..... PDMP-9
  - 3.4 Quality Urban Design ..... PDMP-9
  - 3.5 Sustainability ..... PDMP-10
- 4. Development Policies and Standards ..... PDMP-11
  - 4.1 Land Use Categories ..... PDMP-11
  - 4.2 Design Policies and Standards for Private Development ..... PDMP-11
    - 4.2.1 Overall Design ..... PDMP-12
    - 4.2.2 Residential ..... PDMP-16
    - 4.2.3 Commercial and Office ..... PDMP-17
    - 4.2.4 Light Industrial ..... PDMP-20
  - 4.3 Design Policies and Standards for Public Spaces ..... PDMP-20
- 5. Circulation and Parking ..... PDMP-24
  - 5.1 Circulation ..... PDMP-24
  - 5.2 Parking ..... PDMP-25
- 6. Landscaping ..... PDMP-26
- 7. Signage ..... PDMP-26
- 8. Street Furnishings and Public Art ..... PDMP-27
- 9. Project Development Profiles ..... PDMP-27
  - 9.1 Northern Waterfront ..... PDMP-27
    - 9.1.1 Private Development ..... PDMP-27
    - 9.1.2 Public Spaces ..... PDMP-28
  - 9.2 Central Waterfront ..... PDMP-28
    - 9.2.1 Vallejo Station Concept: Public/Private Partnership ..... PDMP-28
    - 9.2.2 Public Spaces ..... PDMP-32
  - 9.3 Southern Waterfront ..... PDMP-32
    - 9.3.1 Private Development ..... PDMP-32
    - 9.3.2 Public Spaces ..... PDMP-32

**DESIGN GUIDELINES ..... I**

**I. INTRODUCTION ..... I**

    Selected Waterfront Master Plan Objectives ..... I

    Selected Waterfront Master Plan Goals ..... I

**A. Applicability and Organization of the Guidelines ..... 2**

    1. Relationship to Vallejo’s General Plan, Zoning, and Other Policies and Ordinances .....2

    2. Organization of the Design Guidelines Document .....2

    3. Design Principles of the Design Guidelines .....3

        3.1 The Public Realm.....3

        3.2 The Private Realm.....3

    4. Construction and Maintenance of the Public Realm .....3

**B. Framework of the Waterfront Guidelines ..... 4**

    1. Unifying Elements .....4

    2. Linkages and Transitions with the Surrounding City .....5

    3. The Districts of the Vallejo Waterfront .....5

**II. UNIFYING ELEMENTS AND LINKAGES ..... 7**

**A. Waterfront Promenade, Parks, and Open Spaces ..... 7**

    1. Vision .....7

    2. General Parks and Open Space Guidelines.....8

    3. Waterfront Promenade .....8

    4. Construction and Maintenance of Improvements ..... 10

**B. Street Trees, Lighting, and Furnishings..... 11**

    1. Streetscape Elements..... 11

        1.1 Light Fixtures..... 12

            “Waterfront” Standard ..... 12

            “Promenade” Fixtures..... 13

            “Downtown” Standard ..... 14

        1.2 Street Furnishings ..... 14

            Benches ..... 15

            Tree Grates..... 15

            Bicycle Racks ..... 16

            Trash/Recycling Receptacles..... 16

            Bollards ..... 17

            Newspaper Racks..... 17

    2. Trees for Waterfront Streets ..... 18

**C. Major Streets ..... 21**

    1. Mare Island Way .....21

    2. Georgia Street Extension .....24

    3. Marin Street Extension.....24





D. Gateways ..... 25

    1. Primary Gateways ..... 25

    2. Secondary Gateways ..... 26

III. WATERFRONT DISTRICT GUIDELINES ..... 27

A. Guidelines for All Districts ..... 27

    1. Public Realm Guidelines ..... 27

    2. Private Realm Guidelines ..... 27

        2.1 Green Site and Building Design ..... 28

        2.2 Site Design and Building Orientation ..... 30

            2.2.1 Relationship of Buildings to Streets and Open Spaces ..... 30

            2.2.2 Building Entries and Access ..... 31

            2.2.3 Visibility of Ground Floor Activity ..... 33

            2.2.4 Outdoor Recreation, Dining and Display ..... 34

            2.2.5 Off-Street Parking and Drop-off Areas ..... 34

            2.2.6 Off-Street Loading and Service Access ..... 36

        2.3 Human Scale and Building Contribution to the Public Realm ..... 38

            2.3.1 Building Form ..... 38

            2.3.2 Building Articulation ..... 42

            2.3.3 Detailed Design of Outdoor Dining and Display ..... 49

            2.3.4 Transition from Public Realm to Interior Space ..... 50

            2.3.5 Utilities and Mechanical Equipment ..... 51

            2.3.6 Signage ..... 52

B. Southern Waterfront District ..... 55

    1. District Character and Context ..... 55

    2. Public Realm Guidelines ..... 56

        2.1 Waterfront Promenade, Parks, and Open Space Guidelines ..... 56

            2.1.1 Waterfront Promenade Design Elements ..... 56

            2.1.2 Parks and Open Space ..... 57

        2.2 Circulation Guidelines ..... 64

            2.2.1 Street Guidelines ..... 64

        2.3 Gateways ..... 75

            2.3.1 Primary Gateway ..... 75

            2.3.2 Secondary Gateway ..... 75

    3. Private Realm Guidelines ..... 76

        3.1 Site Design and Building Orientation ..... 76

            3.1.1 Relationship of Buildings to Streets and Open Spaces ..... 76

            3.1.2 Building Entries and Access ..... 80

            3.1.3 Visibility of Ground Floor Activity in Mixed-use Buildings ..... 82

            3.1.4 Off-Street Parking Areas ..... 83

            3.1.5 Off-Street Loading and Service Access ..... 87

        3.2 Human Scale and Building Contribution to the Public Realm ..... 88

            3.2.1 Building Form ..... 88

            3.2.2 Building Articulation ..... 91

            3.2.3 Transition from Public Realm to Interior Space ..... 92

            3.2.4 Fences and Low Walls ..... 93

            3.2.5 Utilities and Mechanical Equipment ..... 93

<b>C. Central Waterfront District</b> .....	<b>95</b>
1. District Character and Context.....	95
2. Public Realm Guidelines.....	96
2.1 Waterfront Promenade, Parks, and Open Space Guidelines.....	96
2.1.1 Promenade Overlooks.....	96
2.1.2 Parks and Open Space.....	98
Northern End of Service Club Area (Area A).....	98
Service Club Area at Capitol Street (Area B).....	100
Park and Drop-off Area North of Ferry Building (Area C).....	102
Ferry Terminal Plaza (Area D).....	104
Southern End of Independence Park (Area E).....	106
Vallejo Station Paseo Park (Area F).....	108
Festival Green Extension South of Civic Center Drive.....	112
Public Paseo Through Residential Block.....	114
2.2 Circulation Guidelines.....	114
2.2.1 Street Guidelines.....	114
2.3 Gateways.....	134
2.3.1 Primary Gateway.....	134
2.3.2 Secondary Gateways.....	134
3. Private Realm Guidelines.....	135
3.1 Site Design and Building Orientation.....	135
3.1.1 Relationship of Buildings to Streets and Open Spaces.....	135
3.1.2 Building Entries and Access.....	138
3.1.3 Visibility of Ground Floor Activity.....	140
3.1.4 Off-Street Parking and Drop-off Areas.....	140
3.1.5 Off-Street Loading and Service Access.....	141
3.1.6 Outdoor Recreation, Dining and Display.....	142
3.2 Human Scale and Building Contribution to the Public Realm.....	143
3.2.1 Building Form.....	144
3.2.2 Building Articulation.....	149
3.2.3 Transition from Public Realm to Interior Space.....	151
3.2.4 Utilities and Mechanical Equipment.....	152
<b>D. Northern Waterfront District</b> .....	<b>153</b>
1. District Character and Context.....	153
2. Public Realm Guidelines.....	155
2.1 Promenade Guidelines.....	155
2.2 Parks and Open Spaces Guidelines.....	158
2.2.1 New Wetland Park.....	158
2.2.2 New Promenade Park.....	161
2.2.3 Restaurant Outdoor Patios.....	162
2.2.4 Walls and Fences.....	163
2.3 Circulation Guidelines.....	164
2.3.1 Harbor Way.....	164
2.3.2 Mariner’s Cove Residential Streets.....	169
2.3.3 Mare Island Way and Mare Island Causeway Edges.....	172
2.3.4 Trail Connections.....	175
2.4 Gateways.....	177
2.4.1 Primary Gateway.....	177
2.4.2 Secondary Gateways.....	178



- 3. Private Realm Guidelines ..... 179
  - 3.1 Site Design and Building Orientation ..... 179
    - 3.1.1 Relationship of Buildings to Streets and Open Spaces ..... 179
    - 3.1.2 Building Entries and Access..... 183
    - 3.1.3 Visibility of Ground Floor Activity in Retail Buildings ..... 185
    - 3.1.4 Off-Street Parking Areas ..... 186
    - 3.1.5 Off-Street Loading and Service Access ..... 190
  - 3.2 Human Scale and Building Contribution to the Public Realm ..... 191
    - 3.2.1 Building Form ..... 191
    - 3.2.2 Building Articulation ..... 196
    - 3.2.3 Transition from Public Realm to Interior Space..... 197
    - 3.2.4 Utilities and Mechanical Equipment..... 198
    - 3.2.5 Signage ..... 198
  - 3.3 Neighborhood Open Space ..... 199
    - 3.3.1 Mariner’s Cove Landscaped Paseos and Garden Courts ..... 199

ACKNOWLEDGEMENTS ..... I

## List of Tables

Table 1: Parcel Development Profiles - The Waterfront Project .....	PDMP-33
Table 2: Parcel Development Profiles - The Vallejo Station Project .....	PDMP-35
Table 3: Permitted and Conditional Land Uses - Commercial and Industrial Types ....	PDMP-37
Table 2.B.1: Street Tree Recommendations .....	19
Table 3.A.1: Minimum Floor-to-Ceiling Heights .....	39
Table 3.A.2: Maximum Wall Segment on Publicly Accessible or Visible Facade .....	40
Table 3.A.3: Minimum Window Frontage Guidelines .....	44
Table 3.B.1: Residential Building Setbacks .....	77
Table 3.B.2: Entry Spacing Guidelines .....	82
Table 3.C.1: Entry Spacing Guidelines .....	139
Table 3.D.1: Building Setbacks and Separation .....	181

## List of Figures

Figure A: Vallejo Waterfront Parcel Boundaries Map .....	PDMP-2
Figure B: Parcels J and L and Boundaries Map .....	PDMP-2
Figure C: Proposed Project Land Uses .....	PDMP-6
Figure D: Parcel L - Vallejo Station Height Zone Diagram - Mare Island Way & Maine Street View .....	PDMP-14
Figure E: Parcel L - Vallejo Station Height Zone Diagram - Santa Clara & Georgia Street View .....	PDMP-14
Figure F: Parcel L - Vallejo Station Height Zone Diagram - Plan View .....	PDMP-15
Figure G: Prototypical Top Plate Location .....	PDMP-15
Figure H: Corner Plaza Diagram, Mare Island Way & Georgia Street.....	PDMP-34
Figure I.A.1: Location Maps.....	2
Figure I.B.1: Waterfront Framework Diagram .....	4
Figure I.B.2: Existing and Proposed Roads Addressed in the Guidelines .....	5
Figure I.B.3: Vallejo’s Three Waterfront Districts .....	6
Figure 2.A.1: Waterfront Parks and Open Space Framework .....	8
Figure 2.A.2: The existing promenade provides dramatic views but few amenities for users.....	9
Figure 2.A.3: Plan of Promenade Improvements .....	9
Figure 2.A.4: Section of Promenade Improvements .....	9
Figure 2.A.5 and Figure 2.A.6: Existing public “furniture” within the Waterfront does not create a unified identity. ....	10
Figure 2.A.7: Existing Street Furniture in Downtown.....	10
Figure 2.B.1: Street Furnishing and Light Fixture Concept Diagram .....	11
Figure 2.B.2: “Waterfront” Roadway Lighting Fixture .....	12
Figure 2.B.3: Pedestrian Scale Lighting Fixture Added to Existing Lamp.....	12
Figure 2.B.4: Promenade Fixture #1 .....	13
Figure 2.B.5: Promenade Fixture #2.....	14
Figure 2.B.6: “Downtown” Standard Lighting Fixture .....	14
Figure 2.B.7: Downtown and Waterfront Bench .....	15



Figure 2.B.8: Typical “Hoop” Bicycle Rack.....16

Figure 2.B.9: Downtown and Waterfront Trash/Recycling Receptacle ..... 16

Figure 2.B.10: Waterfront Bollard ..... 17

Figure 2.B.11: Newspaper Rack Example ..... 17

Figure 2.B.12: Diagram of Street Tree Selection within the Waterfront..... 18

Figure 2.C.1: Diagram of Existing and Proposed Streets Addressed in These Guidelines.....21

Figure 2.C.2: Concept for Mare Island Way Streetscape Along Parks and Open Spaces.....22

Figure 2.C.3: Pattern Option 1: Canary Palms.....23

Figure 2.C.4: Pattern Option 2: Frontier Elms.....23

Figure 2.D.1: Diagram of Primary and Secondary Gateways.....25

Figure 3.A.1: Innovative Solutions for Stormwater Crossings.....29

Figure 3.A.2: Raised planters can be used to provide benefits similar to swales.....29

Figure 3.A.3: Buildings should contribute to the public realm.....30

Figure 3.A.4: Buildings should create a direct relationship to sidewalks, plazas, and open spaces to take advantage of the activity in these spaces with ground floor retail or other active uses.....30

Figure 3.A.5: Residential uses should front sidewalks with primary entrances that incorporate porches, stoops, stairs, and the more active interior spaces. ....30

Figure 3.A.6: Some of the most active frontages are created by restaurants and cafes.....31

Figure 3.A.7: Corner entries emphasize important street and sidewalk intersections. ....32

Figure 3.A.8: Multi-family buildings can have individual unit entries accessed directly from the street. ....32

Figure 3.A.9: Plazas can create dynamic spaces where buildings are set back from the street.....32

Figure 3.A.10: Frequent Entries.....33

Figure 3.A.11: Transparency at the ground floor attracts window shoppers and passers by. .33

Figure 3.A.12: Outdoor dining enlivens sidewalks and other pedestrian spaces.....34

Figure 3.A.13 a and b: Figure a (top) is a preferred design for driveways where the sidewalk passes straight and level indicating the primacy of pedestrians. Where sidewalk widths are constrained, the design shown in Figure b (bottom) can be used.....35

Figure 3.A.14: A walkway within a parking lot is made into an attractive and safe pedestrian route with a trellis, landscaping and illuminating bollards.....36

Figure 3.A.15: A loading area is made attractive by incorporating it into the building design and minimizing its frontage along the sidewalk.....36

Figure 3.A.16: Aggregating the width of loading areas with auto driveways can create expansive paved surfaces that are unattractive pedestrian spaces.....37

Figure 3.A.17: (Example of Poor Design) An overly horizontal look paired with a lack of articulation and detail does not create a visually engaging building making perceived walking distances longer for pedestrians. ....38

Figure 3.A.18: Floor-to-ceiling heights at the ground-floor should be taller than upper floors. ....39

Figure 3.A.19: A well-defined base, middle, and top grounds the building and creates a distinct and identifiable termination with articulated eave.....39

Figure 3.A.20: (Example of Poor Design) A blank wall can encourage graffiti and creates frontages that are devoid of interest and activity.....40

Figure 3.A.21: (Example of Poor Design) Color changes alone do not create attractive building facades. Articulation and architectural detailing should also be incorporated.....40

Figure 3.A.22: Artwork can effectively enliven spaces and mask blank walls. ....40

Figure 3.A.23: A tower element provides a distinct architectural element at a street corner creating a memorable feature.....41

Figure 3.A.24: (Example of Poor Design) Roofs that are devoid of interest create abstract buildings that are less engaging to pedestrians.....41

Figure 3.A.25: Articulated rooflines effectively terminate the building and provide interest.....41

Figure 3.A.26: Well articulated massing and facades, ample fenestration, and rhythm in architectural elements create an attractive residential frontage.....42

Figure 3.A.27: Exaggerated and over-sized architectural detailing creates caricature buildings. ....42

Figure 3.A.28: Articulation in the form of an integrated seatwall and an attractive display increase and enhance the interaction between pedestrians and their surroundings.....43

Figure 3.A.29: A well articulated primary residential entry is made distinct from storefront entries with color, change in materials and articulation.....43

Figure 3.A.30: An attractive entry feature announces the primary entrance and emphasizes the street corner.....43

Figure 3.A.31: Attractive Residential Stairs .....44

Figure 3.A.32: Window recesses cast complex shadow lines, creating interest that attracts the eye of pedestrians.....44

Figure 3.A.33: (Example of Poor Design) Care must be taken to avoid situations where office blinds are frequently drawn to create some privacy.....44

Figure 3.A.34: Keeping window sills at 3 feet 6 inches of the finish floor allows desks to be placed against window walls.....45

Figure 3.A.35: (Example of Poor Design) Banks often close blinds for security reasons creating blank walls at the ground floor.....45

Figure 3.A.36: An inviting entry attracts shoppers with a high level of architectural detailing and transparency. ....45

Figure 3.A.37: Retail with High Ceiling and Transom Windows.....46

Figure 3.A.38: Architectural canopies shade a window while creating attractive articulation on a building facade. ....46

Figure 3.A.39: Material changes that do not occur at interior corners do not result in a sense of quality or care. ....46

Figure 3.A.40: (Example of Poor Design) Opaque and reflective glass can create a blank facade along sidewalks and pedestrian spaces.....47

Figure 3.A.41: Glass and metal canopy complements the contemporary architecture of this building and provides protection from rain at the building entrance.....48

Figure 3.A.42: Canvas awnings along these shop fronts provide a comfortable and shaded space for pedestrians to sit and rest, eat, or watch activity along the sidewalk.....48

Figure 3.A.43: Effective building lighting can highlight architectural features and create a comfortable and safe pedestrian environment.....49

Figure 3.A.44: Restaurants with operable window walls allow interior activity to spill out onto sidewalks and open spaces, encouraging a high level of interaction between the public and private realms.....49

Figure 3.A.45: A well-defined primary entrance combined with an appropriately scaled entry plaza to this multi-family building makes the entry inviting and easy to find.....50



Figure 3.A.46: Mechanical equipment can be accommodated within rooflines or behind parapets.....51

Figure 3.A.47: Pedestrian-oriented signs should display a high level of detail. Bright colors and interesting forms can still create a connection with drivers. ....52

Figure 3.A.48: Whimsical signs attract pedestrians with unique designs and contribute to creating memorable places.....52

Figure 3.A.49: Signage that is harmonious with a building’s architecture does not detract from its appearance, but contributes to the overall design. ....53

Figure 3.A.50: (Example of Poor Design) Care should be taken so that window signage does not overwhelm the street frontage, eliminate transparency, or create a chaotic and unattractive environment.....53

Figure 3.B.1: Southern Waterfront District Location.....55

Figure 3.B.2: Land Use Diagram for Southern District .....55

Figure 3.B.3: Promenade Section Location Diagram .....56

Figure 3.B.4: Section of Promenade in Southern Waterfront (typical) .....57

Figure 3.B.5: Area A Key Map .....58

Figure 3.B.6: Area A Guideline Diagram .....58

Figure 3.B.7: Sketch Concept for Area A.....59

Figure 3.B.8: Area B Key Map .....60

Figure 3.B.9: Area B Guideline Diagram .....60

Figure 3.B.10: Sketch Concept for Area B.....61

Figure 3.B.11: Area C Key Map.....62

Figure 3.B.12: Area C Guideline Diagram.....62

Figure 3.B.13: Sketch Concept for Area C .....62

Figure 3.B.14: Marin Street Extension and Section Location Diagram .....64

Figure 3.B.15: Section of Marin Street Extension South of Curtola Parkway .....65

Figure 3.B.16: Section of Marin Street Extension at Residential/Waterfront Park.....66

Figure 3.B.17: Section of Marin Street Extension North of Kaiser Place.....66

Figure 3.B.18: Concept for Marin Street Extension Streetscape at Residential Block .....67

Figure 3.B.19: Roundabout Option at Boat Launch Entry.....68

Figure 3.B.20: Three-Way Stop Option at Boat Launch Entry.....68

Figure 3.B.21: Kaiser Place and Section Location Diagram.....69

Figure 3.B.22: Kaiser Place Cross Section.....69

Figure 3.B.23: Solano Avenue and Section Location Diagram.....70

Figure 3.B.24: Landscape Buffer Treatment - Alternative 2 .....70

Figure 3.B.25: Solano Avenue Cross Section with Landscape Buffer - Alternative I .....70

Figure 3.B.26: Curtola Parkway and Section Location Diagram .....71

Figure 3.B.27: Curtola Parkway Partial Cross Section .....71

Figure 3.B.28: Concept for Streetscape For Curtola Parkway .....72

Figure 3.B.29: Sonoma Boulevard and Section Location Diagram.....73

Figure 3.B.30: Sonoma Boulevard Partial Cross Section.....73

Figure 3.B.31: Mare Island Way and Section Location Diagram.....74

Figure 3.B.32: Partial Section of Mare Island Way at Retail South of Marin Street Extension in Southern Waterfront District.....74

Figure 3.B.33: Diagram of Primary and Secondary Gateways .....75

Figure 3.B.34: Diagram of Relationship of Buildings to Public Realm for the Residential Neighborhood .....76

Figure 3.B.35: R&D/Light Industrial building entries should be designed as gathering places. ....81

Figure 3.B.36: A parking “orchard” provides evenly spaced trees that provide distributed shading .....84

Figure 3.B.37: Buffer sidewalk from surface parking along Solano Avenue.....85

Figure 3.B.38: Units and porches can step down to grade to hide the parking podium behind.....86

Figure 3.B.39: Alternatively, porches, stoops, and stairs can screen the parking podium .....86

Figure 3.B.40: Human-scaled Form and Articulation of Two Story Mixed-Use Building .....88

Figure 3.B.41: Massing and Articulation Diagram for Residential Neighborhood .....89

Figure 3.B.42: Use of Bays, Decks, and Trellises to Create Facade Variation and a Human-Scale .....90

Figure 3.B.43: Building that Anchors a Corner Location .....90

Figure 3.B.44: Poor Example of Rooflines - Not Enough Relief or Variation .....91

Figure 3.B.45: Good Example of Rooflines - Eaves Create Shadow Line and Form that Relates to Interior Use.....91

Figure 3.C.1: Central Waterfront District Location.....95

Figure 3.C.2: Locations of Seating Overlooks.....96

Figure 3.C.3: Section Location Diagram.....97

Figure 3.C.4: Plan of Proposed Promenade Overlook (Option 1) .....97

Figure 3.C.5: Cross Section A-A' of Proposed Promenade Overlook (Option 1).....97

Figure 3.C.6: Plan of Proposed Promenade Overlook (Option 2) .....97

Figure 3.C.7: Cross Section B-B' of Proposed Promenade Overlook (Option 2) .....97

Figure 3.C.8: Key Map for Northern End of Service Club Area (Area A).....98

Figure 3.C.9: Guideline Diagram for Northern End of Service Area (Area A).....98

Figure 3.C.10: Sketch Concept for Northern End of Service Area (Area A) .....99

Figure 3.C.11: Key Map for Northern End of Service Club Area (Area B) .....100

Figure 3.C.12: Guideline Diagram for Service Club Area at Capitol Street (Area B) .....101

Figure 3.C.13: Sketch Concept for Service Club Area at Capitol Street (Area B) .....101

Figure 3.C.14: Key Map for Park and Drop-off Area North of Ferry Building (Area C) .....102

Figure 3.C.15: Guideline Diagram for Park and Drop-off Area North of Ferry Building (Area C) .....102

Figure 3.C.16: Sketch Concept for Park and Drop-off Area North of Ferry Building (Area C) .....103

Figure 3.C.17: Key Map for Ferry Terminal Plaza (Area D).....104

Figure 3.C.18: Ferry Queue Bench – Landscapeforms ‘Presidio’ Backless Bench With Arms105

Figure 3.C.19: Guideline Diagram for Ferry Terminal Plaza (Area D).....105

Figure 3.C.20: Key Map for Southern End of Independence Park (Area E).....106

Figure 3.C.21: Guideline Diagram for Southern End of Independence Park (Area E).....107

Figure 3.C.22: Key Map for Vallejo Station Paseo Park (Area F) .....108

Figure 3.C.23: Guideline Diagram for Vallejo Station Paseo Park (Area F) .....109

Figure 3.C.24: Sketch Concept for Vallejo Station Paseo Park (Area F).....111

Figure 3.C.25: Sketch Concept for Vallejo Station Paseo Park (Area F).....111



Figure 3.C.26: Partial Cross Section of Retail Frontage along Festival Green..... 113

Figure 3.C.27: Plan View of Retail Frontage along Festival Green..... 113

Figure 3.C.28: Georgia Street Extension and Section Location Diagram ..... 114

Figure 3.C.29: Section of Georgia Street Extension at Unity Plaza ..... 115

Figure 3.C.30: Crosswalk System with Countdown Signal and Audible Device for the Visually Impaired ..... 116

Figure 3.C.31: Georgia Street/Civic Center Drive Intersection Alternative ..... 117

Figure 3.C.32: Festival Green Extension at Civic Center Drive Alternative ..... 117

Figure 3.C.33: Cross Section of Civic Center Drive at Residential and Public Parking Garage..... 118

Figure 3.C.34: Santa Clara Street and Section Location Diagram..... 119

Figure 3.C.35: Concept Plan of Reconfigured Santa Clara Street Transit Center..... 119

Figure 3.C.36: Santa Clara Street Cross Section (Option 1)..... 120

Figure 3.C.37: Santa Clara Street Cross Section (Option 2)..... 121

Figure 3.C.38: Santa Clara Street Cross Section (Option 3)..... 122

Figure 3.C.39: Partial Cross Section of Santa Clara Street at Public Parking Garage (in current surface parking lot of City Hall) ..... 123

Figure 3.C.40: Maine Street and Section Location Diagram ..... 124

Figure 3.C.41: Concept Plan of Reconfigured Maine Street ..... 124

Figure 3.C.42: Maine Street Cross Section ..... 125

Figure 3.C.43: Partial Cross Section of Capitol Street at Residential ..... 126

Figure 3.C.44: Mare Island Way and Section Location Diagram ..... 127

Figure 3.C.45: Partial Section of Mare Island Way at Retail ..... 127

Figure 3.C.46: Section of Mare Island Way at Residential..... 128

Figure 3.C.47: Final improvements along Mare Island Way at future extension of Festival Green ..... 128

Figure 3.C.48: Partial Section of Mare Island Way at Restaurant Parking Lot (interim recommendations)..... 129

Figure 3.C.49: Partial Section of East side of Mare Island Way at Festival Green ..... 129

Figure 3.C.50: Mare Island Way between Georgia Street and Maine Street..... 130

Figure 3.C.51: Section of Mare Island Way at Ferry Plaza ..... 131

Figure 3.C.52: Concept for Mare Island Way Streetscape Along Vallejo Station Between Georgia Street and Entry to Ferry Parking..... 131

Figure 3.C.53: Section of Mare Island Way at Ferry Building..... 132

Figure 3.C.54: Crosswalk Design for Mare Island Way at Georgia Street..... 132

Figure 3.C.55: Corner Plaza Diagram, Mare Island Way & Georgia Street..... 132

Figure 3.C.56: Section of Mare Island Way South of Entry to Ferry Parking ..... 133

Figure 3.C.57: Diagram of Primary and Secondary Gateways ..... 134

Figure 3.C.58: Vallejo Station Public and Private Realm Diagram..... 135

Figure 3.C.59: A Well-Defined Building Wall. .... 136

Figure 3.C.60: Ground-floor Residential Entries in an Urban Environment..... 137

Figure 3.C.61: The corner of Georgia Street and Mare Island Way should offer a dynamic and lively place that attracts people..... 137

Figure 3.C.62: Parking garages can be designed to support a high-quality pedestrian environment..... 137

Figure 3.C.63: Frequent store entries activate a street frontage..... 138

Figure 3.C.64: Table 3.C.1 provides guidelines that allow flexibility in the location of entrances for various types of uses. .... 139

Figure 3.C.65: Recessed building entries commonly found in Vallejo’s Downtown provide display or seating space as well as clear space for pedestrians along sidewalks..... 140

Figure 3.C.66: Example of a Well-Designed Entry For a Modern Building Style. .... 140

Figure 3.C.67: (Example of Poor Design) Excessive blank walls along a parking garage creates an uninviting and inactive street frontage and should be avoided..... 141

Figure 3.C.68: A parking structure that accommodates retail at the ground floor and provides interest along the facades creates a much friendlier and lively street frontage..... 141

Figure 3.C.69: (Example of Poor Design) Planters should not exceed a comfortable pedestrian-scaled height. These are too tall..... 141

Figure 3.C.70: Open railings and glass awnings create a transition between sidewalk and the building interior, yet still create an inviting street frontage..... 142

Figure 3.C.71: Human-scale facade design engages the pedestrian’s eye, strengthening their relationship to the pedestrian..... 143

Figure 3.C.72: Example of Building Massing and Scale that Provides Definition to the Corner of Georgia Street and Mare Island Way ..... 144

Figure 3.C.73: The facades of single buildings can be broken up to create a more dynamic street frontage with multiple facade designs, colors and materials..... 145

Figure 3.C.74: Taller buildings should be designed to step back or modulated in order to create compatible building forms on either side of a street. .... 146

Figure 3.C.75: Building Massing and Height Diagram for Vallejo Station ..... 146

Figure 3.C.76: New buildings should complement the scale and articulation of adjacent buildings..... 147

Figure 3.C.77: Transom windows emphasize taller ceiling heights at the ground floor..... 148

Figure 3.C.78: Bays, recesses and overhangs break up the building’s facade to create a dynamic frontage. .... 148

Figure 3.C.79: Facade variation makes Vallejo’s Downtown an engaging and memorable place to visit. New buildings, should also provide variety..... 148

Figure 3.C.80: Juliet balconies can be found on buildings in Vallejo’s Downtown..... 150

Figure 3.C.81: Facades with simple massing are balanced by a series of Juliet balconies that create a human-scaled connection between upper floors and the street. .... 150

Figure 3.D.1: Northern Waterfront District Location..... 153

Figure 3.D.2: Promenade in Eucalyptus Grove ..... 153

Figure 3.D.3: Mariner’s Cove - Proposed Open Spaces, Streets and Development ..... 154

Figure 3.D.4: View from Promenade Across Jazz Festival Green ..... 154

Figure 3.D.5: Promenade Segments in the Northern Waterfront..... 155

Figure 3.D.6: View Across Marina to Causeway Bridge ..... 155

Figure 3.D.7: Photo of Existing Allee of Trees..... 155

Figure 3.D.8: Promenade along the Promenade Park ..... 156

Figure 3.D.9: Example of Promenade Focal Element ..... 156

Figure 3.D.10: Promenade Adjacent to Waterfront Park..... 156

Figure 3.D.11: Example of Allee Envisioned for Connection Between Harbor Way and Promenade. .... 157

Figure 3.D.12: Improvements to Promenade Path and Lighting..... 157

Figure 3.D.13: Location View of the Proposed Wetland Park .....	158
Figure 3.D.14: Example of a Wetland Park .....	158
Figure 3.D.15: Example of a Wetland Park .....	158
Figure 3.D.16: Plan View of the Proposed Wetland Park.....	159
Figure 3.D.17: Proposed Emergency-Vehicle-Access at Wetland Park .....	159
Figure 3.D.18: View Corridor through Wetland Park .....	160
Figure 3.D.19: Example of a Wetland Park Path.....	160
Figure 3.D.20: Example of a Wetland Park Bridge .....	160
Figure 3.D.21: Location of Future Promenade Park .....	161
Figure 3.D.22: Example of Tot Lot Area.....	161
Figure 3.D.23: Example of a Multi-purpose Lawn Area .....	161
Figure 3.D.24: Illustrative Section of Amphitheater .....	161
Figure 3.D.25: Illustrative Site Plan of Promenade Park.....	162
Figure 3.D.26: Location of Restaurant Patios at Promenade .....	162
Figure 3.D.27: Illustrative Plan of Restaurant Patios at Promenade .....	162
Figure 3.D.28: Approximate Location of Passages Through Vertical Landscape Features .....	163
Figure 3.D.29: Harbor Way and Section Location Diagram .....	164
Figure 3.D.30: (Option A - Preferred) Harbor Way Partial Cross Section at Parking with Tree Lawn and Separated Sidewalk .....	165
Figure 3.D.31: (Option B)Harbor Way Partial Cross Section at Parking with Monolithic Sidewalk .....	165
Figure 3.D.32: Harbor Way Partial Cross Section at Parking .....	166
Figure 3.D.33: Harbor Way Cross Section at Park .....	167
Figure 3.D.34: Harbor Way Cross Section at Park .....	167
Figure 3.D.35: Harbor Way Cross Section at Residential .....	168
Figure 3.D.36: Harbor Way Cross Section at Intersection .....	168
Figure 3.D.37: Mariner's Cove Residential Street and Section Location Diagram .....	169
Figure 3.D.38: Mariner's Cove Residential Street Cross Section (Typical).....	169
Figure 3.D.39: Cross Section of Typical Private Court Roadway .....	170
Figure 3.D.40: Cross Section of Typical Private Entryway at T-Court .....	171
Figure 3.D.41: Mare Island Causeway and Section Location Diagram.....	172
Figure 3.D.42: Partial Cross Section of Typical Sidewalk and Lighting Improvements on Southside of Mare Island Causeway .....	172
Figure 3.D.43: Mare Island Causeway (Constrained) - Partial Cross Section .....	172
Figure 3.D.44: Mare Island Way and Section Location Diagram .....	173
Figure 3.D.45: Section of Mare Island Way near Alabama Street .....	174
Figure 3.D.46: Partial Section of Mare Island Way near Ohio Street.....	174
Figure 3.D.47: Sketch Concept of Trail Connection under the Causeway Overpass Looking South.....	175
Figure 3.D.48: Sketch Concept of Trail Connection under the Causeway Overpass Looking North.....	175
Figure 3.D.49: Sketch Concept of Trail Connection under the Causeway Overpass (arrows and lines indicate location of section - See Figure 3.D.50) .....	176
Figure 3.D.50: Partial Cross Section of Mare Island Causeway at Proposed Multi-purpose Trail Ramp Connection to Promenade Extension .....	176

Figure 3.D.51: Diagram of Primary and Secondary Gateways.....177

Figure 3.D.52: Location Diagram for Secondary Gateway at the Intersection of Harbor Way and Mare Island Way.....178

Figure 3.D.53: Design Concept for Secondary Gateway at the Intersection of Harbor Way and Mare Island Way.....178

Figure 3.D.54: Example of Building Relationship to Adjacent Landscaped Passage.....179

Figure 3.D.55: View Corridor and Waterline Setback Lines.....181

Figure 3.D.56: Sample Residential Building Elevation .....182

Figure 3.D.57: Sample Residential Building Elevation .....184

Figure 3.D.58: Restaurant with French Doors to Dining Area .....185

Figure 3.D.59: A sidewalk is buffered from an adjacent parking lot by an attractively landscaped wall and overhead trellis.....186

Figure 3.D.60: A hedge buffers a sidewalk from adjacent parked cars. In the evening, the hedge can prevent headlights from shining on pedestrians.....186

Figure 3.D.61: Wheelstops and low-growing groundcovers keep car overhangs from destroying landscaping within parking lots.....187

Figure 3.D.62: An orchard configuration maximizes shade for parked cars.....187

Figure 3.D.63: Landscaping can break up large asphalt areas within parking lots.....187

Figure 3.D.64: Pedestrian Access at Waterfront Retail .....188

Figure 3.D.65: Example of Swale with Ornamental Planting .....188

Figure 3.D.66: Example of Grassy Swale .....188

Figure 3.D.67: Cross Section of Buffer Between Parking and Path Along the Edge of Promenade Park .....189

Figure 3.D.68: Example of Entry Porches that Enhance and Articulate Individual Building Entries.....191

Figure 3.D.69: Sample Elevation Illustrating Residential Building Massing .....192

Figure 3.D.70: Sample of a Residential Building Elevation .....193

Figure 3.D.71: Example of Craftsman Style Roof.....195

Figure 3.D.72: Example of Victorian Style Roof .....195

Figure 3.D.73: Location of a Proposed Landscaped Paseo.....199

Figure 3.D.74: Example of a Landscaped Paseo .....199

Figure 3.D.75: Sketch Plan of a Proposed Landscaped Paseo .....200

Figure 3.D.76: Illustrative Cross Section through Proposed Landscaped Paseo .....200



## Preamble

In October of 2005, the Vallejo City Council/Redevelopment Agency adopted the Planned Development Master Plan (PDMP) for the Waterfront and Vallejo Station Projects, and the Vallejo Waterfront Design Guidelines, which are an incorporated attachment to the PDMP. This publication is a compilation of those two documents.

Both documents' overarching objective is to enable and guide the development of Vallejo's Waterfront area so that the Waterfront and neighboring Downtown regain their historic place as the cultural heart of the community. This is to be achieved through revitalization with quality development that is pedestrian and transit-friendly, and that includes higher density commercial, office, and residential uses, along with innovative public spaces for cultural and recreational activities.

The PDMP represents the zoning for all three Waterfront Districts (the Northern, Central, and Southern Districts) and outlines key design criteria and minimum standards for development in the Districts. The Design Guidelines set forth in greater detail the policies and standards for land use and design in the Districts. Both, the PDMP and the Design Guidelines include specific goals, objectives, policies, and design concepts from the City of Vallejo's *Waterfront/Downtown Master Plan for Public Spaces* that was prepared in 2000. Where the City of Vallejo Zoning Ordinance has rules or policies that go beyond the purview of the PDMP and the Design Guidelines, the projects will need to comply with those rules or policies as determined by the Community Development Division of the City of Vallejo.

The combined document of the PDMP and Design Guidelines is intended to assist future developers and the City to implement specific projects in a manner consistent with the Planned Development Master Plan. Furthermore, the document allows citizens and stakeholders to gain an understanding of the future distribution and intensity of land uses in the Districts and the design character intended for each individual District.

In order to ensure the overall high level of design quality and consistency of proposed projects with the goals and requirements of the PDMP and Design Guidelines, a design review process for all projects in the Waterfront Plan Area has been established. As part of this process, projects will be reviewed by the Design Review Board (DRB), which evaluates and acts on all projects in the Plan Area. All DRB actions will be recommendations to the City Council for final design related approvals. The PDMP and its attached Design Guidelines will be used by City staff, the Design Review Board, and elected officials, throughout this evaluation.

It should be noted that several other documents also inform the development criteria for the Vallejo Station and Waterfront projects. Those documents are:

- The Third Restated Disposition and Development Agreement
- The Second Restated Development Agreement
- The Settlement and Release Agreement by and between the City of Vallejo, City of Vallejo Redevelopment Agency, Callahan DeSilva Vallejo, LLC and the Vallejo Waterfront Coalition
- The Mitigation Monitoring and Reporting Program from the 2005 Certified CEQA Document
- The 2004 Master Labor Agreement with the Labor Unions

Elements that are a result of the Settlement Agreement are noted as (S.A. 2006).



***Vallejo Waterfront  
Planned Development Master Plan***



# Planned Development Master Plan

## 1. Introduction

This document is the Planned Development Master Plan (PDMP) for the Waterfront and Vallejo Station Projects. The PDMP outlines design criteria and minimum development standards for the northern, the central and the southern portions of Vallejo’s waterfront. The PDMP is one component of the Vallejo Station Project and Waterfront Project (“Project”) entitlements that include the following actions:

- Approval of a Disposition and Development Agreement with a Master Developer;
- Amendment of the text of the General Plan and the designations on the General Plan’s Land Use Map in the Project area;
- Rezoning of the Project area;
- Adoption of the PDMP to set forth the policies and standards for land use and design for the project area, and including as an incorporated attachment, the *Vallejo Waterfront Design Guidelines* to assist future developers and the City in implementing specific projects in a manner consistent with the land use and design standards; and
- Adoption of a Development Agreement pursuant to Government Code Section 65864 et seq.

The PDMP was developed pursuant to Chapter 16.116 Planned Development Permit Procedure of the Vallejo Municipal Code. The PDMP was adopted as an ordinance and it serves as the zoning land use regulations for development within the defined planning area.

### 1.1 Plan Area and Setting

This PDMP encompasses approximately the 92 acre area bounded on the west by the Mare Island Strait, on the north by the Mare Island Causeway, on the east by Downtown Vallejo, and on the south by Solano Avenue. The area’s major streets are Mare Island Way, which runs parallel to the waterfront, and Georgia Street, which is the main east-west thoroughfare through the City of Vallejo. The boundaries of the plan parcels are illustrated on Figures A and B.

There are several major influences on the physical setting of the planning area that have contributed to the development of the plan. These include 1) the location of the area along the waterfront of Mare Island Strait at the western edge of the historic downtown; 2) the former Mare Island Naval Shipyard across Mare Island Strait to the west; 3) the surrounding historic residential areas of the Heritage District, Washington Park neighborhood and St. Vincent’s Hill Historic District, and the Vallejo Heights neighborhood north of the plan area; 4) the access to the 780 freeway via Curtola Parkway, access to the I-80 freeway via Curtola Parkway and Sonoma Boulevard, and access to State Route 37 via Mare Island Way and Wilson Avenue; and 5) the redeveloping industrial area in South Vallejo along Sonoma Boulevard (Hwy 29) and Mare Island Strait.

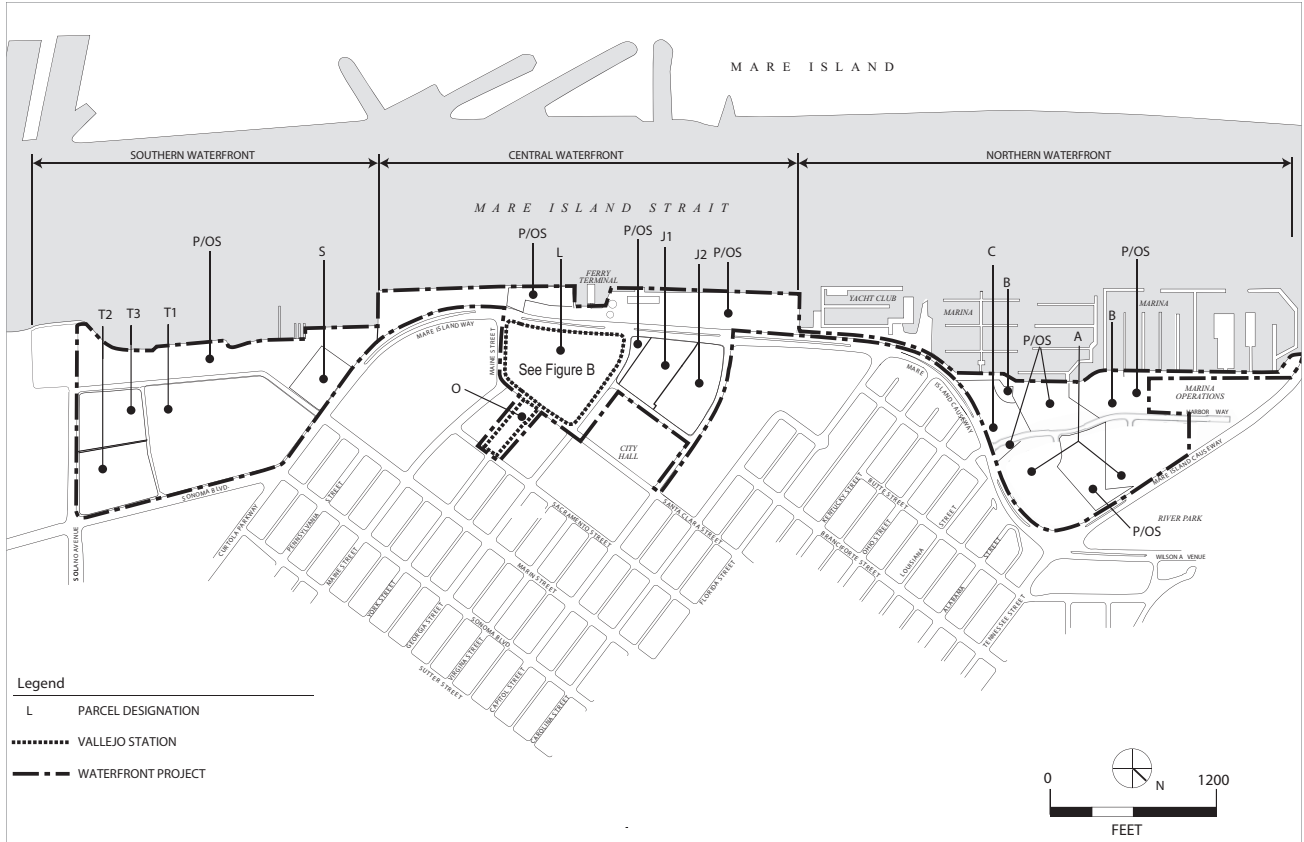

Figure A: Vallejo Waterfront Parcel Boundaries Map

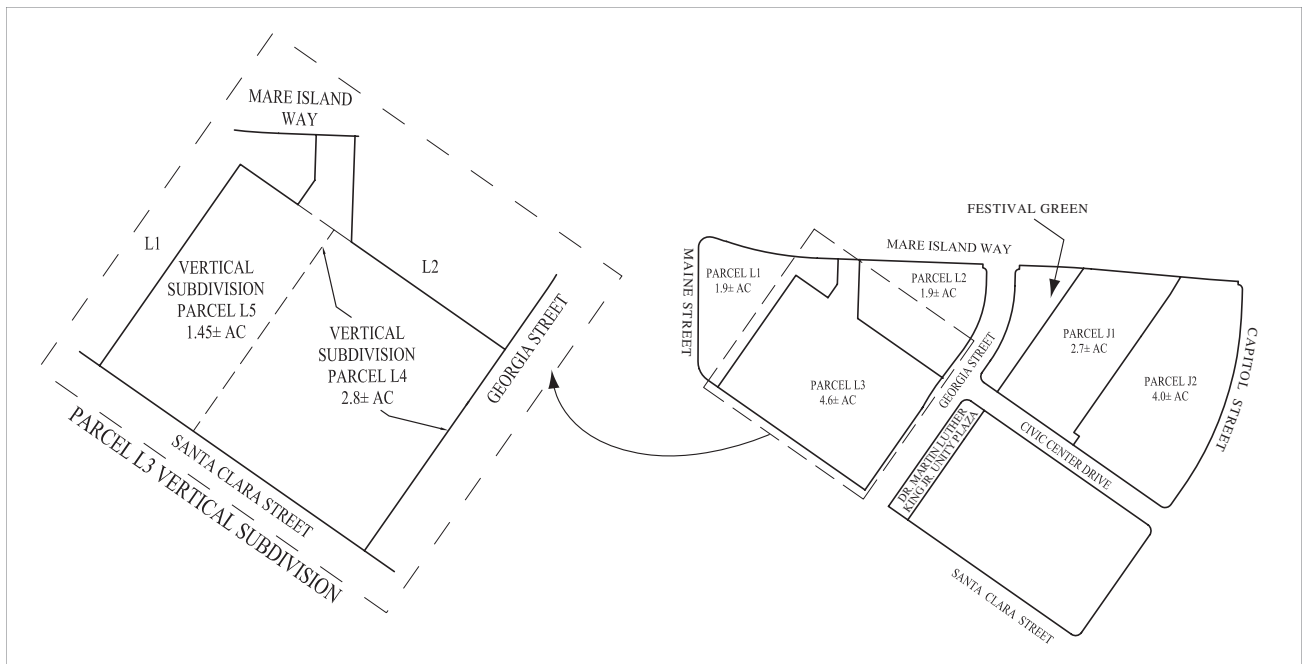

Figure B: Parcels J and L and Boundaries Map

## 1.2 Planning Process

In May 1997, the City of Vallejo Redevelopment Agency entered into an Exclusive Right to Negotiate Agreement with DeSilva Callahan LLC as the Master Developer for the Agency-owned parcels along the Vallejo waterfront. Through an 18-month public planning process, a conceptual Master Plan was developed. This Master Plan proposed mixed-use development and redevelopment of the waterfront and a portion of Vallejo's historic downtown. The Master Plan included residential, commercial and open space uses and public improvements related to circulation and access along the waterfront and the City of Vallejo ferry service to San Francisco. The Agency accepted the conceptual Master Plan on April 20, 1999, and directed an additional step in the planning process.

The Agency retained the services of the Urban Land Institute (ULI) to review the Master Plan. The ULI Advisory Services Panel met June 27-30, 1999 in Vallejo. The Panel's conclusions endorsed the Master Plan with some modifications. The Agency considered this modified Plan and accepted it on August 24, 1999. With this acceptance, the completion of a Disposition and Development Agreement (DDA) with the Master Developer was initiated.

On February 15, 2000, during a status report on the waterfront planning process, the Agency directed staff to consider alternative land uses for certain sites in the planning area and to bring back recommendations to the Agency. On March 28, 2000, the Agency accepted the Master Plan as modified by staff's recommendations.

At the same time, the Agency retained Wallace, Roberts & Todd, Inc. (WRT), a planning and landscape architecture firm with national and international experience, to develop a conceptual plan for the public spaces within the Waterfront/Downtown planning area. WRT undertook this process with the assistance of the Waterfront/Downtown Design Advisory Committee, a group of citizens representing a cross-section of the community and a variety of views on waterfront development.

On August 22, 2000, the DDA was approved subject to the completion of environmental review and other land use and redevelopment actions.

On September 19, 2000, the Agency considered WRT's *Vallejo Waterfront/Downtown Master Plan for Public Spaces* ("Public Spaces Plan"). The Agency directed that the Public Spaces Plan be incorporated into the Vallejo Waterfront Project for analysis in the environmental impact report. Further, the Agency directed the Public Spaces Plan's recommendations for private parcels be used as input into the development of land use and design standards for such parcels, recognizing that the final PDMP for public spaces and private parcels would not be approved until the certification of the EIR.

On June 5, 2001, the Agency held a public study session regarding the Waterfront/Downtown Master Plan for Public Spaces. The purpose of the study session was to review proposed changes to the land use profiles previously developed. The creation of a transit center strengthened in its relation to the downtown and waterfront area was now emphasized as the key element to successfully revitalizing the Waterfront/Downtown area. The "Vallejo Station Transit Center" design concept now assumed significance for its role in reconnecting the downtown with the waterfront, defining a public open space framework of street corridors and green space, and strengthening Vallejo's identity. Design concepts revolved around creating an extension of the downtown street grid to the waterfront, the creation of a Civic Center complex, the enhancement of multi-modal public transit opportunities and related redevelopment opportunities. The Redevelopment Agency accepted the proposed changes to the Waterfront Master Plan on July 10, 2001.



In 2002, a Draft EIR was prepared for the Waterfront and Vallejo Station projects. Following Planning Commission recommendation of certification of the DEIR, changes were made to the Waterfront project by the City Council in October 2003 to amend the Disposition and Development Agreement (DDA) with the master project developer, to remove Parcel K from the project area and to allow construction of the Capitol Street extension through the project area.

Following City Council action, a State Farm Insurance Company electronic payment center was constructed on former Parcel K.

In August 2004, a second amendment to the DDA as approved to implement changes in the processing of the Program level EIR to a Project level EIR, to describe the merger of the three redevelopment areas, removal of Parcels K, U and V from the project area and to update the original scope of development and the schedule of performance.

The City authorized the preparation of the *Vallejo Waterfront Design Guidelines*, which are intended to supplement this PDMP document relating to community planning and urban design. These design guidelines are included as a component of the PDMP.

In June 2005, a Revised Draft Environmental Impact Report (RDEIR) on the Vallejo Station and Waterfront projects was released for a 60-day public review period. Following the close of the comment period, all comment letters were responded to and a Final Environmental Impact Report was prepared. In October 2005, a Final Environmental Impact Report was published.

In November 2005 the RDEIR was certified and project entitlements were approved by the City Council. By early December 2005 a lawsuit was filed by a community based interest group named the Vallejo Waterfront Coalition. Citing concerns over the potential inadequacies in the certified RDEIR, 10 months of negotiations ensued and a final settlement agreement was reached by December 2006. (S.A. 2006) The PDMP and *Vallejo Waterfront Design Guidelines* are the final results of the incorporation of the City/Agency/Developer partnership and community input into an environmentally balanced and financially viable master plan for the Vallejo Waterfront.

### 1.3 Project Objectives

The objective of the PDMP is to enable the revitalization of Vallejo's waterfront area and, in conjunction with the Downtown Specific Plan, help to revitalize the adjacent historic downtown. This will occur with land use actions and associated redevelopment actions to ensure that:

- Revitalization is financially feasible;
- The waterfront and downtown regain their historic place as the cultural heart of the community; and
- The waterfront and downtown are revitalized with quality development that is pedestrian- and transit-friendly and that includes higher-density commercial, office and residential uses with innovative public spaces for cultural and recreational activities.

Without the Project, Vallejo's waterfront will remain underutilized and blighted into the foreseeable future, and the community will not receive the benefit of the cultural, retail, employment, housing and recreation opportunities provided by the Project.



## 1.4 Planning Goals

Through the community process facilitated by the Master Developer (MD) and the subsequent process by WRT, goals were established to guide the planning efforts. Both sets of goals were very similar in that they shared a common vision for the waterfront area. The goals have been modified to reflect current conditions in the plan area, including but not limited to construction of the State Farm building, Georgia Street extension and others.

### 1.4.1 Planning Goals for Private Development

- Incorporate mixed land uses, which are people-oriented and which will allow the waterfront and downtown areas to evolve into the social, cultural and entertainment hub of the city. (MD)
- Take advantage of the recent Georgia Street extension and the remaining planned Capitol Street and Marin Street extensions to: create marketable properties adjacent to the waterfront while preserving and enhancing land for public open space; enhance the linkage between the downtown commercial area and the waterfront; and increase and enhance crossings of Mare Island Way, making it more pedestrian-friendly. (MD)
- Develop extensive public access and public park and open space areas along the waterfront. (MD)
- Create new and revitalized existing residential neighborhoods within and adjacent to the waterfront and downtown areas. (MD)
- Design new development in an architectural style that is compatible with the existing character of the historic downtown and adjacent residential neighborhoods. (MD/City)
- Ensure that land uses in the waterfront area will be compatible with and linked to those anticipated on Mare Island. (MD)
- Encourage private investment in the downtown and adjacent residential neighborhoods. (MD)

### 1.4.2 Planning Goals for Public Spaces

- Issues of Use Goal: Balance commercial, residential, employment and transportation uses with recreational, festival, events and other associated uses so that each are accommodated and each help to create synergy for the waterfront and downtown as they function in combination with one another. (WRT)
- Issues of Connection Goal: Enhance connections between the waterfront, downtown and Mare Island utilizing physical and visual connections to the greatest extent possible. (WRT)
- Issues of Culture Goal: Develop a concept for the waterfront that is rooted in the cultures of Vallejo and celebrates its uniqueness. (WRT)
- Issues of Design Goal: Develop a design theme for the waterfront which will reflect the unique identity of Vallejo, celebrate the water's edge and incorporate distinctive elements which will all combine to make a place which is truly unique and which ensures Vallejo's position as one of the world's great waterfronts. (WRT)
- Issues of Sustainability Goal: Concerns of sustainability as they relate to social, ecological and economic issues should figure strongly in the development of the waterfront concept. (WRT)

## 1.5 Vision Statement

As a result of the planning process, a statement was developed to set the theme for the revitalization of the waterfront and downtown:

Coming Back to the Future – Bringing the Downtown Back to the Waterfront: Create a distinctive Waterfront/Downtown for Vallejo which reflects the community’s sound values of Ecology, Citizenry, Rich History, A Real Place and Downtown as the Heart of the Community. The new waterfront and downtown should be a celebration of Vallejo’s ethnic and maritime culture, and the waterfront’s connection to the downtown should be strengthened in every way possible. In addition to strengthening Vallejo’s distinctive identity, the waterfront should emphasize pedestrian and other non-vehicular circulation modes, accommodate a wide variety of recreation activities, festivals and events, encourage boating and other water-oriented uses and provide opportunities for associated urban residential, commercial and civic uses. (WRT)

## 2. PDMP Summary

The PDMP addresses the development and redevelopment of the waterfront planning area as shown in Figure C. The overall concept is to have continuous public access and open space along the Mare Island Strait waterfront between the extension of Solano Avenue in the south to the Mare Island Causeway in the north. More intense urban uses are set back from the waterfront edge to create a bridge between the existing downtown and the waterfront. Within the plan area, there are up to 1,251 new higher-density residential units and up to 562,000 gross square feet of new private mixed-use commercial, office, research & development/light industrial and developed recreation. A major hotel with associated conference and retail facilities is also included.

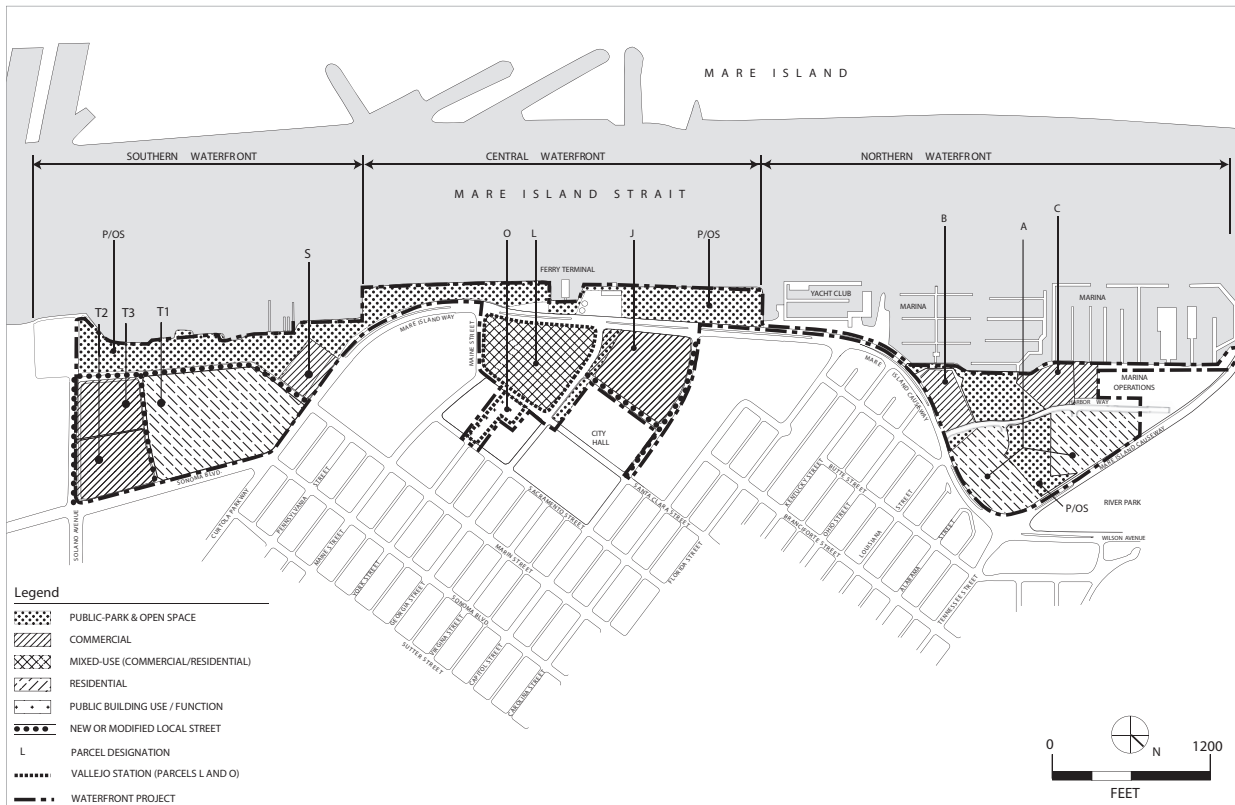

Figure C: Proposed Project Land Uses

New public facilities include a below-grade parking structure known as Vallejo Station to serve existing and future ferry service and other uses in the area. These public facilities complement the existing Civic Center and Ferry Terminal. Public space increases from the existing 11 acres to approximately 35 acres within the planning area. A large Festival Green and existing Dr. Martin Luther King Jr. Unity Plaza (formerly Unity Plaza) form the centerpiece of the public spaces. Public art is incorporated into Dr. Martin Luther King Jr. Unity Plaza and is encouraged to be installed along the waterfront.

The connection between the waterfront and downtown is further strengthened by the extension of the historic street grid to the waterfront where practical with the completed extension of Georgia Street and the partial extension of Capitol Street, which will be extended to Santa Clara Street when the Vallejo Station garage is completed. Other streets that are extended as part of the historic grid, where practical, are Branciforte (Civic Center Drive)<sup>1</sup> and Marin Streets.

The planning area is divided into three smaller geographic areas: Central Waterfront, Northern Waterfront, and Southern Waterfront. While the proposed land uses in each area are summarized below, more detailed descriptions of future development are described in Section 9 of this PDMP.

### 3. **Overriding PDMP Goals and Policies**

There are five overriding goals with associated policies that govern all private development and public improvements. It is the intent of these goals and policies to ensure that the waterfront area is redeveloped and revitalized in the following manner:

- As a pedestrian-oriented mixed-use District;
- With an integrated urban fabric;
- With visual access and orientation to the waterfront;
- With quality urban design, and
- As an example of sustainable development.

#### 3.1 **Pedestrian-Oriented Mixed Use District**

- *Goal 1:* Establish the waterfront planning area as an attractive pedestrian-oriented, mixed-use District.
- *Policy 1A:* Enhance the economic and recreational potential of the area by promoting the relocation, revitalization, or redevelopment of existing uses or businesses that are not oriented to the waterfront. In their place, encourage the introduction of uses that will contribute to the creation of a vibrant, pedestrian-oriented, mixed-use District. (WRT Policy 30)
- *Policy 1B:* Provide landowners/developers with the flexibility to respond to market factors as they change over time with the mixed-use concept. (WRT Policy 31)
- *Policy 1C:* Encourage the development of a mixed-use District to enhance the “around-the-clock” vitality of the area, by incorporating uses that attract people during all periods of the day and week whether for habitation, employment or entertainment. (WRT Policy 25)
- *Policy 1D:* Encourage mixed-use development as a means of reducing automobile use within the planning area. Development of complementary uses (retail and office, retail and housing, office and housing) in proximity to each other allows residents, employees, and visitors to walk and/or bicycle

when undertaking many of the typical daily trips, whether it is going to lunch, running errands, or going out for the evening. (WRT Policy 26)

- *Policy 1E:* Balance retail uses with a mix of cultural, entertainment, residential and office uses that will complement and support the economic vitality of the downtown commercial core. (WRT Policy 27)
- *Policy 1F:* Contribute to the concept of the planning area as a community focal point and activity center through commercial activities that provide distinctive retail and entertainment uses that cater to and will be used by the community. (WRT Policy 28)
- *Policy 1G:* Encourage housing that addresses the needs of a diverse population, including age, household composition and income. A range of unit types should be considered, including but not limited to town homes, court homes and podium style units. Creating just residential areas with just traditional single-family units is not the most efficient use of the limited land resources within the planning area. (WRT Policy 33/City/MD)

### 3.2 Integrated Urban Fabric

- *Goal 2:* Establish the waterfront area as an economically and socially vital center for Vallejo.
- *Policy 2A:* Employ the design of the public realm, including parks, plazas, sidewalks and streets, to reintegrate the waterfront into an active commercial area that will serve as both a citywide and regional destination. (WRT Policy 22)
- *Policy 2B:* Provide an integrated open space system that enhances the aesthetic character of the downtown and establishes a distinctive identity for Vallejo’s waterfront. (WRT Policy 23)
- *Policy 2C:* Establish the approximately 35 acres of public open space in the Vallejo Station and Waterfront project as a citywide open space amenity, and a focal feature and recreational amenity for the downtown. (WRT Policy 24)
- *Policy 2D:* Create an integrated system of urban open spaces that accommodates pedestrian movement throughout the development areas and links the development areas to the waterfront open spaces. (WRT Policy 54)
- *Policy 2E:* Create a continuous public zone along the water’s edge that provides a minimum width of public promenade, improved relationships to the water’s edge and key green space penetrations into the urban edge. (WRT Policy 1)
- *Policy 2F:* Require project designs to incorporate pedestrian and transit linkages within the project, with adjacent properties and with the city as a whole. (MD)
- *Policy 2G:* Reestablish the historic city grid in the public spaces of the Waterfront/Downtown area by means of physical connections (street and paseo) and/or visual connections as practical. (WRT Policy 2)
- *Policy 2H:* Incorporate green spaces projecting back into the urban edge where practical. Reinforce these green spaces with landscape and urban design features that help to frame the view orientation out to the water. (WRT Recommendation 1)
- *Policy 2I:* Create a continuous pedestrian connection through the City Hall and City parking lots in the area between Sacramento Street and the extension of Civic Center Drive. (WRT Policy 53)<sup>2</sup>
- *Policy 2J:* Provide a pedestrian-oriented environment within the downtown and waterfront areas, with convenient pedestrian connections to adjoining neighborhoods. (WRT Policy 55)

### 3.3 Visual Access and Orientation

- *Goal 3:* Preserve and enhance visual access to the waterfront in new private and public development.
- *Policy 3A:* Encourage uses in areas adjacent to the waterfront open space that will benefit from their proximity to this important open space resource. Development whose orientation is completely internal, such as performing arts center, theaters, conference facilities, etc. should not be located adjacent to waterfront open space. (WRT Policy 29)
- *Policy 3B:* Locate uses that will most benefit from views of the waterfront and associated open space improvements so that they have positive orientation and access to the available visual amenities. Such uses include restaurants, residences, offices and hotel rooms. Uses, such as conference facilities, that are primarily internally oriented should be located where access to visual amenities is lower or include landscape and urban design features that are supportive of public activity in open spaces. (WRT Recommendation 30)
- *Policy 3C:* Preserve view corridors in new development along the alignment of city streets where practical. (WRT Recommendation 28)
- *Policy 3D:* Preserve the alignment of the visual corridor established by the predominant right-of-way alignment through building massing in situations, such as the Georgia Street and Capitol Street extensions, where the actual street right-of-way bends to make right angle connections with Mare Island Way, where practical. (WRT Policy 29)
- *Policy 3E:* Emphasize the orientation of new development to the waterfront and public open space through the placement of building entries and by maximizing the area of fenestration facing open space amenities. (WRT Recommendation 31)
- *Policy 3F:* Incorporate balconies and upper level terraces in addition to windows into building designs that provide additional opportunities for people to appreciate the area's visual assets where practical. (WRT Recommendation 32)
- *Policy 3G:* Remove, relocate or redesign existing waterfront development that either obstructs visual access to Mare Island Strait or does not significantly benefit from the visual amenities associated with its location where practical. (WRT Policy 52)

### 3.4 Quality Urban Design

- *Goal 4:* Encourage the highest and most creative standards for urban design in new private and public development.
- *Policy 4A:* Design new development to address directly and openly adjacent open space by incorporating windows and pedestrian entrances along these frontages. (WRT Recommendation 33)
- *Policy 4B:* Design new development to incorporate courtyards, plazas, passageways, roof terraces and other open spaces in order to complement, extend and enrich the pattern of pedestrian-oriented public open spaces. (WRT Recommendation 34)
- *Policy 4C:* Use original designs that are tailored to the site rather than generic or trademark buildings and site design. (MD)
- *Policy 4D:* Promote designs that achieve a balance between appearance and function, where form and function rely on each other for a successful project design. (MD)

- *Policy 4E:* Use designs that add to the character of the community by providing opportunities for integration of the project with adjacent properties. (MD)
- *Policy 4F:* Establish a streetscape presence and appearance through setbacks, landscaping, building placement and architecture that defines the pedestrian and vehicular corridor and that presents an appealing and continuous theme along a sidewalk or street. (MD)
- *Policy 4G:* Commercial projects should provide connections between neighborhoods, adjacent compatible uses and area-wide trail systems. (MD)
- *Policy 4H:* Commercial projects should provide continuous pedestrian walkways in the public right-of-way or designated landscape corridor. (MD)
- *Policy 4I:* Parking lots, service areas and other less attractive building elements should generally not be located adjacent to open space amenities such as plazas and parks. (WRT Recommendation 35)

### 3.5 Sustainability

- *Goal 5:* Include the principles of sustainability in the implementation of the PDMP where practical.
- *Policy 5A:* Institute water conservation techniques when feasible. (WRT Standard 11a)
- *Policy 5B:* Utilize native or drought-resistant plants where appropriate. (WRT Standard 11b)
- *Policy 5C:* Use recycled and/or recyclable materials when feasible. (WRT Standard 11c)
- *Policy 5D:* Promote energy conservation through the use of efficient lighting and utility systems. (WRT Standard 11d)
- *Policy 5E:* Use wood products from renewable, non-old growth forestry practices when feasible. (WRT Standard 11e)
- *Policy 5F:* Promote ecological/habitat diversity within the open space. (WRT Standard 11f)
- *Policy 5G:* Use nontoxic building materials either in manufacturing process or in final product state. (WRT Standard 11g)
- *Policy 5H:* Use materials from local sources to reduce transportation impacts when feasible. (WRT Standard 11h)
- *Policy 5I:* Design integrated storm water management systems that promote filtration, percolation, retention and detention when feasible. (WRT Standard 11i)
- *Policy 5J:* Utilize pest and weed management practices that reduce or eliminate leaching of pesticides and herbicides into the groundwater or into adjacent wetlands and/or bodies of water. (WRT Standard 11j)
- *Policy 5K:* Design grey-water irrigation systems as a water conservation technique when feasible. (WRT Standard 11k)
- *Policy 5L:* Use designs that show awareness of and consideration for the energy requirements of a proposed design with respect to heating, cooling and material selection. (MD)

Refer to *Vallejo Waterfront Design Guidelines Section A.2.1 Green Site and Building Design* for direction on implementation.



## 4. Development Policies and Standards

### 4.1 Land Use Categories

- *Civic*: This category includes public and/or quasi-public uses that provide noncommercial services, such as cultural facilities, government facilities, parking, and transportation and essential services.
- *Residential*: This use category includes types of residential units with higher-densities that will take advantage of their close proximity to the waterfront and its amenities, transportation facilities and downtown.
- *Commercial*: This use category is for the provision of commercial goods and services to the residents, visitors, workers and transportation users within the Waterfront/Downtown area. These goods and services include retail, lodging, food, cultural, recreation, entertainment, personal services and visitor-serving uses.
- *Office*: This category includes two types of business uses. The first type of uses are small businesses where the public can generally enter for services such as legal, administrative, financial, real estate and professional. The second type of uses includes businesses and professional uses on a scale larger than usually found in retail commercial areas. These uses are not generally open to individual customers.
- *Research & Development/Light Industrial*: This category includes industrial uses such as manufacturing and research and development that are low intensity and clean in character. They can be conducted entirely in enclosed buildings or in screened outdoor areas, and they generate a minimum of truck traffic.
- *Developed Recreation – Public*: This category includes public and/or quasi-public uses that provide active public recreation facilities and/or services, such as parks, playgrounds and event areas.
- *Developed Recreation – Private*: This use category includes active recreation services that are privately operated, such as fitness facilities, bicycle rentals or tennis clubs.
- *Open Space*: This category includes uses that are public and/or quasi-public for resource preservation, interpretation and passive recreation.
- *Uses Requiring Conditional Use Permits*: A few land uses require additional review to ensure operating characteristics do no impact adjacent uses. Major conditional use permits are required for off-site alcohol sales and on-site alcohol sales (except in bona fide eating establishments or as an accessory use within the hotel within the planning area).

### 4.2 Design Policies and Standards for Private Development

The following section contains overall standards for all development in the PDMP area as well as specific standards for residential, commercial, office, and research & development/light industrial uses. The accompanying attachment, *Vallejo Waterfront Design Guidelines*, provides explanatory overall design guidance for the PMDP area along with more specific design guidance for individual types of land uses envisioned in the plan and for each waterfront area.

**Design Review Program:** Establish a design review process within one year of adoption of the plan for all projects in the Waterfront Project plan area. The process should include a Design Review Board that evaluates and acts on all projects in the plan area. This function would be performed by the Planning Commission until the Design Review Board is formed.

## 4.2.1 Overall Design

### 4.2.1.A Policies

- *Policy:* Ensure that the architectural theme of all new development is compatible but not necessarily consistent with the character of the historic downtown and adjacent neighborhoods.
- *Policy:* Buildings within the Vallejo Waterfront shall directly orient towards the streets, sidewalks, parks, plazas and promenade that form the public realm.
- *Policy:* The more active uses in a building shall front onto sidewalks and open spaces. For commercial buildings this includes storefronts, dining areas, office and hotel lobbies, or other semi-public spaces within offices. For civic uses, this should be the front lobby and any retail component associated with the use. For residential uses, this includes lobbies, porches to individual unit entries, living rooms, dining rooms, and the work portion of live-work units.
- *Policy:* Outdoor dining shall comply with the City of Vallejo’s “Outdoor Dining Performance Standards” as established in the City’s Zoning Ordinance.
- *Policy:* In the design of parking structures and surface lots, walkways should be an integral part of the design process. Designs shall comply with the most up-to-date ADA and Title 24 accessibility requirements.
- *Policy:* All loading and service (refuse and recycling, utility, etc.) areas shall be located and designed to minimize visual impacts and their presence along sidewalks, pedestrian corridors and other public spaces.
- *Policy:* The height of awnings and canopies should provide pedestrian scale to the building and also meet code requirements. Awnings and canopies shall be at least 8 feet above the sidewalk, and may project no more than 2/3 of the width of the sidewalk or a maximum of 10 feet. Valances on the edge of an awning parallel to the building face should not be more than 12 inches wide.
- *Policy:* All exterior lighting shall be designed so as to not produce glare onto pedestrian spaces and adjacent uses.

### 4.2.1.B Standards

- *Standard:* Modern expressions of the historic building vocabulary, including massing, scale, detail and materials, shall be used.
- *Standard:* Replicas of historic architectural styles shall not be used.
- *Standard:* Adequate detailing, visual interest and durable materials shall be used.

Refer to Tables 1 and 2 of this PDMP for maximum building heights and building height standards for all parcels in the three Waterfront Districts.

Refer to *Vallejo Waterfront Design Guidelines Section III.A Guidelines for All Districts* and individual District Sections for direction on implementation.



### Central Waterfront

- *Standard:* 1) Parcel J building height shall be measured from the street curb perpendicular to the midpoint of the building to the building top plate; 2) Parcel L building height shall be measured from the street curb perpendicular to the midpoint of a given parcel zone to the building top plate, as depicted in Figures D, E, F and G.
- *Standard:* On Parcels J and L: 1) Decorative features, including, but not limited to, parapets, spires, bell towers, domes, cupolas, obelisks, and monuments, and pitched roofs or pitched roof elements, including, but not limited to, dormers, shall be limited to a maximum height of six (6) feet above the building top plate; 2) If any architectural element such as a dormer or vaulted ceiling increases the interior ceiling height of the top unit, it shall be limited to a maximum of three (3) feet above the top plate; 3) Elevator or stair towers, chimneys, ventilators, plumbing vent stacks, water tanks, cooling towers, machinery rooms and other mechanical equipment and appurtenances shall not be subject to these height limits and shall be appropriately screened in accordance with the PDMP and *Vallejo Waterfront Design Guidelines*.

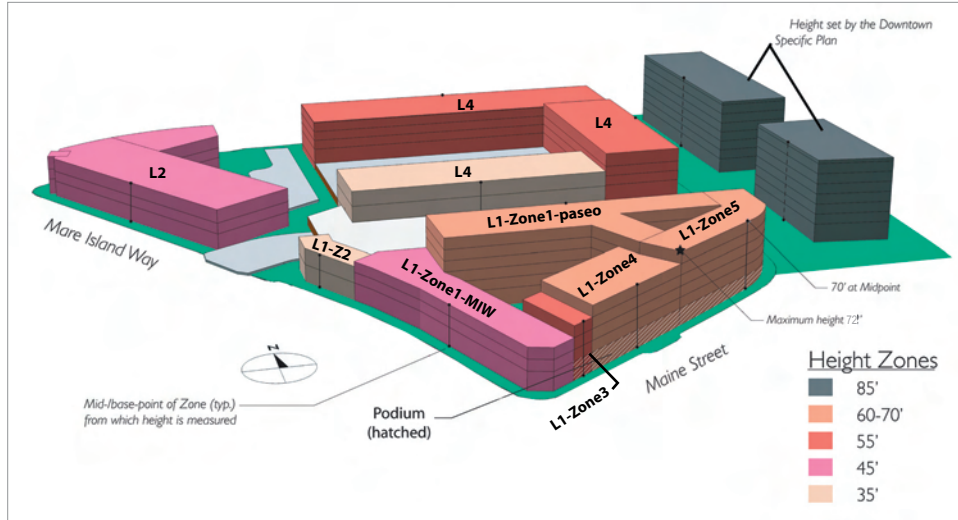

Figure D: Parcel L - Vallejo Station Height Zone Diagram - Mare Island Way & Maine Street View

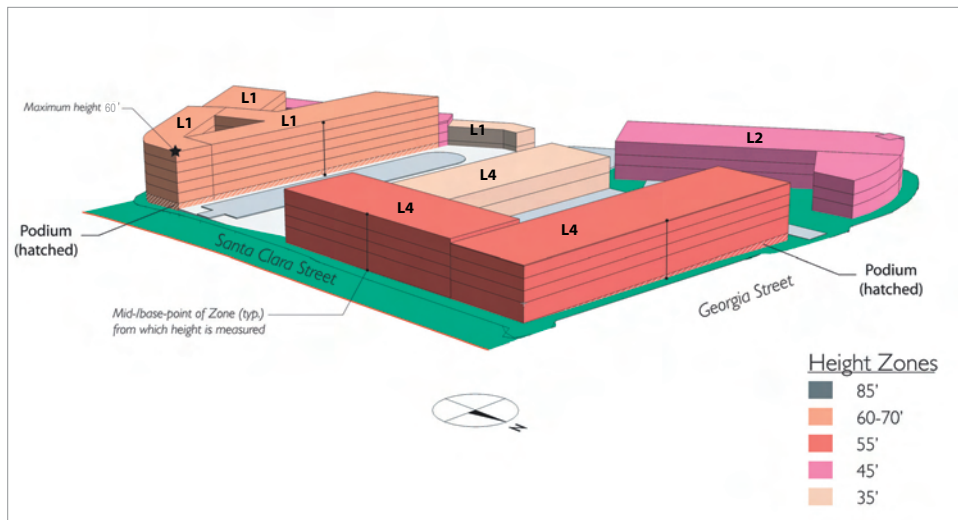

Figure E: Parcel L - Vallejo Station Height Zone Diagram - Santa Clara & Georgia Street View



Figure F: Parcel L - Vallejo Station Height Zone Diagram - Plan View

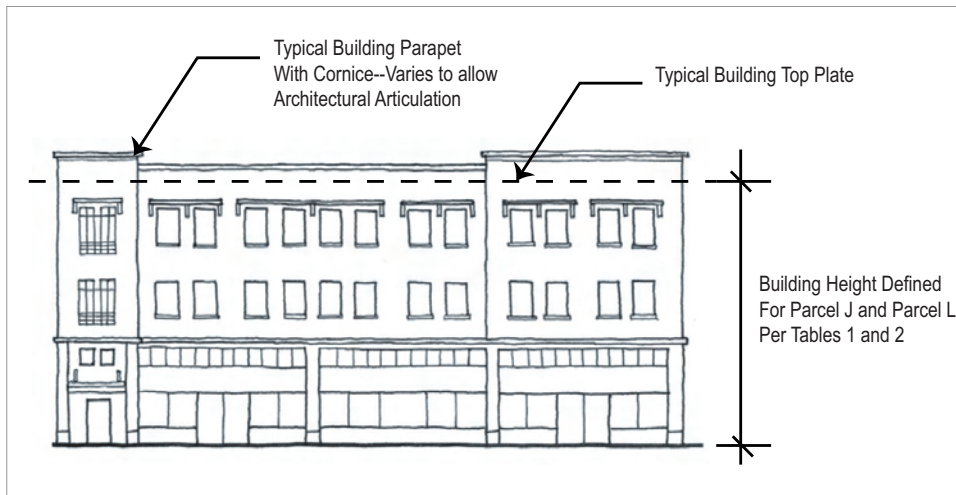

Figure G: Prototypical Top Plate Location

## 4.2.2 Residential

### 4.2.2.A Policies

#### Northern Waterfront

- *Policy:* To decrease the overall visual impact for the residential development, the taller pitched roof residential buildings shall be located in the Northern Neighborhood with the lower pitched roof buildings located in the Southern Residential Neighborhood (See *Vallejo Waterfront Design Guidelines* Figure 3.D.3).

#### Central Waterfront

- *Policy:* The north and south sides of the Paseo Park are fronted by Vallejo Station buildings that *shall* provide active frontages onto the Park, such as residential stoops or stairs leading to individual residential units, the conference facilities, retail storefronts, secondary entries to the hotel, residential lobbies, entries to residential internal courtyards that provide views of the interior landscape, and/or entries to ground level live/work units.
- *Policy:* Regardless of the use that fronts onto Civic Center Drive, if improved, the design of the sidewalks *shall* be as illustrated in *Vallejo Waterfront Design Guidelines* Figure 3.C.33 with a 6-foot wide tree well with grate and a 6-foot minimum width of sidewalk from the tree well to the edge of the right-of-way.

#### Southern Waterfront

- *Policy:* First-floor residential units along the Marin Street extension and Kaiser Place shall have individual entries that directly relate to these streets.

### 4.2.2.B Standards

#### Podium Units

- *Standard:* Design of structures should avoid long, unbroken walls on the project perimeter. (MD)
- *Standard:* All building façades should be well-articulated to avoid blocky appearance. Variations in window treatments, roof lines and vertical elements should be emphasized. (MD)
- *Standard:* Utilize generous eaves and overhangs to soften and ground the architecture by adding horizontal shadow and texture to the buildings especially when viewed from a distance. (MD)
- *Standard:* Provide quality and scale through the use of textured materials such as masonry and siding. (MD)
- *Standard:* Variations in roof lines and massing should be used. (MD)
- *Standard:* Implement quality architectural detailing including window trim, recessed windows and built-up fascias. (MD)
- *Standard:* Where feasible, first-floor units should have individual entries or stoops that directly access the public or common areas. (MD)
- *Standard:* Portions of the garage that are visible from adjacent public streets and areas should be concealed using architectural elements such as grills, stairs and landscaping. (MD)
- *Standard:* Garage access should be between or at the rear of buildings. Where garage opening must occur along a street frontage, the openings should be recessed into the building. (MD)

- *Standard:* Landscaping on the top of the podium should attempt to create a pedestrian-oriented zone between building clusters by providing planters, changes in landscape material, naturalistic plantings and water features. (MD)

Refer to *Vallejo Waterfront Design Guidelines Section III.A Guidelines for All Districts, Section III.B Southern Waterfront District, and Section III.C Central Waterfront District* for direction on implementation.

### **Townhouse Units**

- *Standard:* Building heights in Parcel A shall be measured from the street or alley curb perpendicular to the midpoint of the street or alley to the ridge of the roof structure. Chimneys shall not be subject to this height measurement and shall be allowed to exceed the height limit. (S.A. 2006)
- *Standard:* All units within a cluster should share common visual links, such as architectural themes, details, materials and colors. (MD)
- *Standard:* All building façades should be well-articulated to avoid blocky appearance. Variations in window treatments, roof lines and vertical elements should be emphasized. (MD)
- *Standard:* Variations in rooflines and massing should be used. (MD)
- *Standard:* Entries should be visible from the street or parking area for attached cluster. (MD)
- *Standard:* Covered porches or stoops at entries are encouraged along the street to activate the street and provide a transition between the public street and the private residence. Where appropriate, one-story rooflines can be used for porches or stoops to reduce building mass. (MD)
- *Standard:* Where feasible, and appropriate to the character of the neighborhood, the impact of garage doors should be reduced using second story overhangs or trellises. (MD)
- *Standard:* In order to increase landscaping within the parking areas, paving should be reduced where possible. (MD)
- *Standard:* Decorative paving should be used for the parking areas to create an identity separate from the street. (MD)
- *Standard:* Provide quality and scale through the use of textured materials such as masonry and siding. (MD)

Refer to *Vallejo Waterfront Design Guidelines Section A. Guidelines for All Districts and Section III.D Northern Waterfront District* for direction on implementation.

## **4.2.3 Commercial and Office**

### **4.2.3.A Policies**

#### **Northern Waterfront**

- *Policy:* Buildings shall create a well-defined, visually interesting, and continuous building wall with few interruptions from parking lots, driveways, and inactive open spaces and landscape areas.
- *Policy:* Retail building at the corner of Harbor Way and Mare Island Way (Parcel C): The northeastern face of the building shall be set back from the edge of the Harbor Way westerly curb line by 35 feet to provide a view corridor from Mare Island Way and elevated areas of the St. Vincent's Hill neighborhood into the site and to boat masts and views of the waterfront. Landscaping in this setback should be selected and designed as an integral part of the future gateway at the entry to Harbor Way (See *Vallejo Waterfront Design Guidelines* Figure 3.D.53, 3.D.54, and 3.D.55).

- *Policy:* Restaurant Building at Promenade - No portion of the restaurant building shall be located closer to the higher water mark than 55 feet as defined by the Bay Conservation Development Commission; (Also see *Vallejo Waterfront Design Guidelines* Figure 3.D.55). The building and its surrounding landscaping and hardscaped “patio” seating areas should engage the promenade and make activity within the building visible to the promenade (See *Vallejo Waterfront Design Guidelines* Figure 3.D.27).
- *Policy:* There will be no parallel parking on Harbor Way from its intersection with Mare Island Way northerly to a point past the visual corridor between the Promenade and Wetland Parks.

### Central Waterfront

- *Policy:* The frontages of Georgia Street and Mare Island Way from Capitol to the ferry parking garage driveway should be considered as prime space for commercial uses that can take the greatest advantage of a high degree of pedestrian traffic. The sidewalks for these streets shall be fronted by uses that activate them at the ground-floor such as storefronts, restaurants, cafes, the work portion of live/work units, hotel and conference center lobbies, and the most active spaces within offices such as the front lobby. For ground-floor retail, active storefronts or display areas should turn the corner for at least 50% of the façade along the Ferry parking garage driveway in order to activate this important pedestrian route.
- *Policy:* Parking structures should include active ground-floor uses such as retail to create a pedestrian-supportive interface with the surrounding sidewalk, particularly on more active street frontages such as Georgia Street, Santa Clara Street, and Mare Island Way (See *Vallejo Waterfront Design Guidelines* Figure 3.C.68). On more minor streets, parking structures shall, at a minimum, be buffered with landscaping if active ground-floor uses are impractical. Façades should be designed with equal attention to form and articulation as other buildings within the Central Waterfront. Parking structures may also be built to include ground-floor retail in the future with minor retrofitting.
- *Policy:* Every retail establishment and/or live/work unit shall have its own entry directly from or connecting to a publicly accessible sidewalks, walkway, or plaza space, such as the Paseo Park.
- *Policy:* Visibility of any sloping floors and long horizontal openings shall be avoided.
- *Policy:* At a minimum, screening *shall* include landscaping, landscaped planters, decorative architectural detailing such as metal and grill work, or changes in materials and colors. Planters that are too tall should be avoided.

Refer to *Vallejo Waterfront Design Guidelines Section III.C.2.2.A Architectural Detailing – Scale and Ornamentation* for additional landscape planter guidelines.

#### 4.2.3.B Standards

- *Standard:* All ground-level commercial uses should have their primary entrances oriented to the street. In general, entrances should be frequent, with the specific spacing informed by the predominantly existing spacing pattern of entries of the land use type. (WRT Recommendation 22)
- *Standard:* Building height is measured from the top plate to the mean elevation of the surrounding street curbs, excluding peaked roofs, mechanical equipment, roof screens for roof mounted equipment, and minor building projections used to create architectural character and accent. (MD)
- *Standard:* The ground-level street frontage should be dominated by active commercial or public-oriented uses and be lined with windows. (WRT Recommendation 19)



- *Standard:* Clear, untinted glass should be used to achieve maximum transparency when it is appropriate to expose commercial uses to the street. Windows, French doors and other façade treatments (in addition to the front door) that open onto the street are encouraged when appropriate. (WRT Recommendation 25/MD)
- *Standard:* Entries should be emphasized through building articulations and form and oriented to address the main street. (MD)
- *Standard:* Roof-mounted equipment shall be screened from public view. (MD)
- *Standard:* Innovative use of durable, high quality materials, such as brick, stone, tile, stucco and certain forms of concrete, is encouraged. (MD)
- *Standard:* The materials, shapes, elements and details used on the front or main building elevation, including the roof style and materials, should be extended to all elevations. (MD)
- *Standard:* Texture and color should be used to create visual interest and enhance the streetscape appearance of the building. (MD)

Refer to *Vallejo Waterfront Design Guidelines Section A Guidelines for All Districts* and individual District Sections for direction on implementation.

### **Parcels B and C**

- *Standard:* Building height is measured from the top of the parapet or top plate to the mean elevation of the surrounding street curbs, excluding peaked roofs, mechanical equipment, roof screens for roof mounted equipment, and minor building projections used to create architectural character and accent. (MD)

Refer to *Vallejo Waterfront Design Guidelines Section A. Guidelines for All Districts* and *Section D. Northern Waterfront District* for direction on implementation.

### **Parcel J**

- *Standard:* Locate ground level retail and restaurant uses that are open to the public along the Festival Green and Mare Island Way frontages to add visual interest and encourage pedestrian activity. (MD)
- *Standard:* Use scale and massing along the Capitol Street frontage that are sensitive to the residential neighborhoods. (MD)
- *Standard:* The residential development will also include on-site landscaping in courtyards and perimeter landscaping.

Refer to *Vallejo Waterfront Design Guidelines, Section A. Guidelines for All Districts* and *Section III.C Central Waterfront District* for direction on implementation.

### **Parcel L**

- *Standard:* Building heights generally shall step down in a westerly direction from Santa Clara Street to Mare Island Way, as depicted in Figures D, E and F of this PDMP. Also see Table 2 for maximum building heights and building height measurement standards for Parcel L.

Refer to *Vallejo Waterfront Design Guidelines, Section A. Guidelines for All Districts* and *Section III.C. Central Waterfront District* for direction on implementation.

## 4.2.4 Light Industrial

### 4.2.4.A Standards

- *Standard:* Main building entries should be integrated into the façade along the Marin Street Extension to focus pedestrian activity onto this street and be emphasized through building articulation, building form, or architectural detailing so the entry is easily identified and visible from the main street and parking lot. (MD)
- *Standard:* Stairs and other entry access requirements such as wheelchair ramps should be integrated into the overall building design. (MD)
- *Standard:* Building entries and street-side façades should have a pedestrian scale. Windows, awnings, trellises, arcades, landscape planters and material changes should be used to achieve this. (MD)
- *Standard:* Rooflines, wall planes and wall heights should be varied and significantly articulated to avoid blank expanses of building mass. (MD)
- *Standard:* Landscaping and architectural detail at the street level should be used to soften the edge of the building and enhance the pedestrian scale and streetscape. (MD)
- *Standard:* Blank walls in areas where pedestrian traffic occurs are discouraged. Landscaping and architectural treatment should be used to create a comfortable environment for pedestrians. (MD)
- *Standard:* Innovative use of durable, high quality materials, such as brick, stone, tile, stucco and certain forms of concrete, is encouraged. (MD)
- *Standard:* The materials, shapes, elements and details used on the front or main building elevation, including the roof style and materials, should be extended to all elevations. (MD)
- *Standard:* Texture and color should be used to create visual interest and enhance the streetscape appearance of the building. (MD)

Refer to *Vallejo Waterfront Design Guidelines, Section A. Guidelines for All Districts* and *Section III.B. Southern Waterfront District* for direction on implementation.

## 4.3 Design Policies and Standards for Public Spaces

The following design standards and objectives are based on the many improvement projects envisioned in the WRT Plan for Public Spaces which sets forth the city's vision for the improvement of public spaces within the PDMP area. It is recognized that the implementation of this vision will require substantial investment and will be dependent on the availability of adequate funding. The accompanying *Vallejo Waterfront Design Guidelines*, adopted on October 25, 2005 as an implementation document, provides overall design concepts and direction for key open spaces in each of the waterfront areas.



### **Project-Wide Objective**

- *Policy:* All public open space Improvement Projects shall be subject to a public design process to be determined by City Council.

### **Waterfront Promenade**

- *Policy:* The waterfront within the PDMP will contain a public promenade for the purpose of providing extensive public access.
- *Standard:* The public promenade will maintain its current width of 30 feet within the Central Waterfront to allow for combined pedestrian, bicycle and other wheeled mode (skates, skateboards, etc.) circulation in both directions. (WRT Standard 1a)
- *Standard:* In the central area along the festival green, alternative pedestrian interaction with the water's edge and small boat access should be provided if feasible. (WRT Standard 1b)
- *Standard:* To the extent that funding is available, the seawall railing will be redesigned to provide a more aesthetically pleasing appearance and a better pedestrian relationship with the water's edge. (WRT Standard 1c)
- *Standard:* Promenade widths within the Northern Waterfront should allow for combined pedestrian and other non-motorized, wheeled modes of circulation in both directions. (WRT Standard 8a).
- *Standard:* Promenade widths along the water in the Southern Waterfront District will be a minimum of 14 feet along the water's edge to allow for combined pedestrian and other non-motorized, wheeled modes of circulation in both directions. (WRT Standard 9a).

Refer to *Vallejo Waterfront Design Guidelines Chapter II Unifying Elements and Linkages, Section A. Guidelines for All Districts* and individual District Sections for direction on implementation.

### **Festival Green/Other Open Space Improvements**

- *Policy:* Relocate “linear” festivals and events, including the Yacht Race, Whaleboat Regatta, North Bay Boating Festival, Lighted Boat Parade, Trawler Festival and potentially a new “Kite Days” festival to the wing areas on either side of the Festival Green. It may be appropriate for certain boat-related festivals to extend into the Northern Waterfront area adjacent to the Marina. (WRT Policy 14)
- *Standard:* Provide power sources for vendor booths and performance venues along the greens. (WRT Standard 14a)
- *Standard:* Provide picnic areas in appropriate locations within the greens. (WRT Standard 14b)
- *Policy:* A large, triangular “Festival Green” will be established adjacent to the Georgia Street extension as it intersects with Mare Island Way. The Green will be a triangular configuration as shown in the master plan extending all the way to the water's edge and will have a combination of hard and soft surfacing to accommodate a variety of functions including a performance venue. (WRT Policy 4 and Figure H of this PDMP).
- *Standard:* Lawn areas will be constructed to accommodate heavy foot traffic in this area. (WRT Standard 4a)
- *Standard:* Hard surfaces will be designed to accommodate light service truck access and in the case of the back stage area, the hard paving will be designed to accommodate semi-tractor/trailer loads. (WRT Standard 4b)

- *Standard:* The performance stage will be outfitted with electrical power outlets to accommodate major performances. (Standard 4c)
- *Standard:* Provide power sources for performance venues and vendor booths. Provide grey-water dump points as needed. Design areas for installation of portable restrooms during festival events. (WRT Standard 12a)
- *Standard:* A 3.5-acre park will be located on the water side of Harbor Way and is intended to provide a generous public open space that accommodates a variety of recreation functions including periodic use during the annual Jazz Festival. (WRT Standard 8b)

Refer to *Vallejo Waterfront Design Guidelines Chapter II Unifying Elements and Linkages* and individual District Sections for direction on implementation.

### **Dr. Martin Luther King Jr. Unity Plaza**

- *Policy:* A long, rectangular public plaza will be established on the Georgia Street axis spanning either side of Santa Clara. The design of this plaza will include setback standards and street paving standards as necessary to create a continuous plaza surface that can accommodate vehicular uses as well as a wide variety of pedestrian uses and functions. (WRT Policy 5)
- *Standard:* The plaza paving will be continuous across pedestrian and vehicular areas with either a curb or bollard separation to designate vehicular lanes. No parallel parking will be permitted in this segment in order to maintain the sense of pedestrian space at all times. (WRT Standard 5c)
- *Policy:* The City will maintain the ability to close public streets depending on the size and extent of festival activities that are occurring in Dr. Martin Luther King Jr. Unity Plaza. (WRT Policy 6)
- *Policy:* Expand the farmers market to extend it to the end of the new Dr. Martin Luther King Jr. Unity Plaza. Institute the annual Vallejo Arts Festival utilizing the Georgia Street downtown corridor and Dr. Martin Luther King Jr. Unity Plaza. (WRT Policy 13)
- *Policy:* Provide power sources for vendor booths and performance venues along Georgia Street and in Dr. Martin Luther King Jr. Unity Plaza. (WRT Standard 13a)

Refer to *Vallejo Waterfront Design Guidelines Section III.C.2.1.2 Parks and Open Space* for direction on implementation.

### **Wetland Park**

- *Policy:* A 4.0 acre public wetland park (the “Wetland Park”) shall be created in a central location between the two townhouse neighborhoods, the “Northern Residential Neighborhood” adjacent to the Mare Island Causeway and across Harbor Way from the existing restaurant known as Zio Fraedo’s, and the “Southern Residential Neighborhood” adjacent to Mare Island Way. (S.A. 2006)
- *Policy:* The site plan for the residential development area shall include public access through the new residential neighborhoods to the Wetland Park from Mare Island Way and the north end of Harbor Way. The design will invite pedestrians to walk through the new residential neighborhoods to the Wetland Park from the adjacent Mare Island Way and the Mare Island Causeway sidewalks. (S.A.2006)
- *Policy:* A pedestrian pathway will be provided along the southern sidewalk of the Mare Island Causeway in approximately the same location as the existing pathway. The pathway will provide a connection from the Mare Island Causeway, through the residential neighborhood, crossing Harbor Way and through a portion of the marina parking in the proximity of the Parcel B1, to the Waterfront Promenade and will be enhanced with paving and a stop sign or other traffic control mechanism at intersection(s) with vehicle thoroughfares. (S.A. 2006)

- *Policy:* A three-hour (3) parking time limit (for daytime hours, seven (7) days a week) shall be included for the on-street parking spaces located along the west side of Harbor Way and any street abutting the Wetland Park. (S.A. 2006)
- *Policy:* The Wetland Park shall be centrally located and consist of a minimum of 4.0 contiguous acres, with approximately 1.5 to 1.7 acres comprised of vegetated swales, wetland terraces, and a tidal pond connected to the Mare Island Straight. (S.A. 2006)
- *Policy:* The 4.0 acre size shall not be reduced to accommodate any non-park use, including but not limited to the residential development, parking, public and private streets, and "paseos" or perimeters of the private development that are not contiguous to the Wetland Park open space. (S.A. 2006)
- *Policy:* The Wetland Park will create a visual amenity with interpretive features, provide for passive recreation, and re-create a naturalistic drainage system. (S.A. 2006)
- *Policy:* An observation area will contain interpretive features that will explain the wetland system, cleansing of stormwater, and tidal pond/brackish water ecology. (S.A. 2006)
- *Policy:* The swales will range from ten (10) feet to forty (40) feet in width including vegetated buffer areas adjacent to the swales. At its narrowest, between the two townhouse neighborhoods, the Wetland Park will be a minimum of 120 feet wide. (S.A. 2006)
- *Policy:* The open space, while not formally programmed, will provide a variety of spaces for individuals and groups to relax and enjoy the natural surroundings. (S.A. 2006)
- *Policy:* The Wetland Park shall be dedicated in fee to the City for park purposes and maintained by the City using assessments generated by a Landscape and Lighting Maintenance District, or other similar funding mechanism, as provided for in the DDA and subject to the City's annual budgetary process. (S.A. 2006)

Refer to *Vallejo Waterfront Design Guidelines Section I.D.2.2.1 New Wetland Park* for direction on implementation.

### **Circulation and Improvements**

- *Policy:* View corridors should be maintained coinciding with city streets to ensure strong visual connections to the waterfront from adjacent residential neighborhoods, where practicable. (WRT Recommendation 4)
- *Policy:* Marin Street should be extended into the Southern Waterfront area and along with the existing Sonoma Boulevard will provide connections to the city grid and facilitate pedestrian circulation and visual links between the waterfront and existing downtown. (WRT Recommendation 5)

Refer to *Vallejo Waterfront Design Guidelines Section A. Guidelines for All Districts* and individual District Sections for direction on implementation.

### **Fishing Pier**

- *Policy:* Keep the existing fishing pier and keep or relocate the boat launch area to the southern edge of the Southern Waterfront public open space. Reconfigure the adjacent parking area and pedestrian circulation area.

Refer to *Vallejo Waterfront Design Guidelines Section B.2.1 Waterfront Promenade, Parks, and Open Space Guidelines* for direction on implementation.

## 5. Circulation and Parking

The following policies and standards are based in large part of the urban design recommendations in the WRT Plan for Public Spaces. The accompanying *Vallejo Waterfront Design Guidelines* document provides cross sections of roadways, sidewalks, and areas adjacent to sidewalks (as applicable) and policies for streets, crossings, parking, and other elements of the circulation network in each of the waterfront areas.

### 5.1 Circulation

#### *Intersection Signalization*

- *Policy:* Signalized intersections with enhanced pedestrian crossings will be installed along Mare Island Way and Curtola Parkway at the Capitol, Georgia, and Marin Street extensions and Sacramento Street extension (if it occurs at the corner of the Kaiser property), in addition to the ones that already exist at Sonoma, Florida, Harbor Way and Tennessee. (WRT Policy 16)

#### *Mare Island Way Improvements*

- *Policy:* Mare Island Way will be reconfigured to allow two lanes in each direction with parking and a bicycle lane along the curb on each side (See *Vallejo Waterfront Design Guidelines* Figures 3.C.46, 3.C.50, 3.C.54, and 3.C.56).

#### *Street Extensions*

- *Policy:* Georgia Street has been extended to Mare Island Way and Capitol Street has been partially extended toward Santa Clara Street. Designate these streets along with Santa Clara Street and Sonoma Boulevard, as primary roads. (WRT Policy 19)

#### *Civic Center Drive Improvements*

- *Policy:* Prior to the contemplation of connecting Civic Center Drive through to Georgia Street, the City and the Developer shall study the possibility of not creating the intersection of Civic Center Drive and Georgia Street. The City shall obtain an independent opinion from a qualified traffic engineer regarding whether the associated intersections' level of service (the "LOS") anticipated in the Final EIR, for the Project can be maintained without the extension of Civic Center Drive through the Festival Green to Georgia Street. The City shall conduct a pre-study meeting to solicit comments from interested parties, regarding the scope of the study. The Developer shall fund the cost of this study. In the event it is determined that such LOS cannot be maintained, and Civic Center Drive is to be extended through the Festival Green to Georgia Street, the traffic engineering study also shall include an analysis of possible measures (such as removable bollards) to prevent bisecting the Festival Green and the adjacent pedestrian area during non-peak traffic times. (S.A. 2006)

Refer to *Vallejo Waterfront Design Guidelines Section III.C.2.2.1.B Civic Center Drive* for direction on implementation.

#### *Paseos*

- *Policy:* Selected streets will be created as pedestrian-oriented paseos allowing no vehicular through traffic. (WRT Policy 20)

Refer to *Vallejo Waterfront Design Guidelines Section III.C.2.1.2 Parks and Open Space* and *Section III.D.3.3.1 Mariner's Cove Landscaped Paseos and Garden Courts* for direction on implementation.

## 5.2 Parking

The following policies and standards relate to on-street and off-street parking

### Off-street Parking

- *Policy:* In order to enhance the pedestrian environment and visual character of the area, new off-street surface parking should not be located between the street and the building frontage. Surface parking lots should generally be located behind buildings. In the Northern Waterfront, buildings that are directly oriented toward the Waterfront Promenade may accommodate parking between the building and the adjacent street; preferably to the side of the building. Parking lots to the sides of buildings will be acceptable in limited situations provided they do not create a significant break in the continuity of the building façades along the street frontage. Reasonable accommodation should be made for corner parcels. (WRT Recommendation 27)
- *Policy:* The capacity and use patterns of existing public parking lots (e.g., Library, City Hall, etc.) should be evaluated to determine possibilities for sharing with other downtown/waterfront uses. (WRT Policy 50)
- *Policy:* Parking for the ferry, downtown commercial operations and public events will be consolidated in a new parking structure. In order to take advantage of its proximity to both the Ferry Terminal and the downtown, the structure will be located on the Santa Clara Street site that currently includes the Post Office, the former Denny's restaurant and the surface ferry parking lots. (MD)
- *Policy:* The parking structure will be sized to include spaces needed to accommodate parking needs for expanded ferry service and new commercial and residential development proposed on the parking structure site. (MD)
- *Policy:* In order to reduce its visual prominence, the parking structure will be built into the existing slope and situated below-grade to the extent feasible with the high water table. (MD)
- *Policy:* In order to integrate the parking structure into the urban pattern and take full advantage of the site's development potential, the retail, office and residential uses will be integrated into the structure. The Mare Island Way and Georgia Street façades of the structure will be fronted with commercial (retail and/or office) and lobbies for upper floors. The civic Center Drive façade will be designed to minimize the perceived mass of the structure. The roof of the structure will be developed with some mixture of commercial, residential and public uses, including open space. (MD)
- *Policy:* In order to enhance the retail and pedestrian environment and supplement the parking capacity provided by the parking structure, on-street parking will be encouraged along all waterfront and downtown streets. (MD)

Refer to *Vallejo Waterfront Design Guidelines Section A. Guidelines for All Districts* and individual District Sections for direction on implementation.

### On-street parking

- *Policy:* On-street parking will be maximized for the Downtown/Waterfront area to encourage visitation to this District and to minimize the need for large surface parking lots. (WRT Policy 21)
- *Policy:* In order to enhance the retail and pedestrian environment and supplement the parking capacity provided by the parking structure, on-street parking will be encouraged along all waterfront and downtown streets. This action will not only increase the parking capacity in the downtown, but will serve as a traffic calming measure to calm vehicle speeds on downtown streets. (WRT Policy 51)

Refer to *Vallejo Waterfront Design Guidelines Section III.C.2.2 Circulation Guidelines* for direction on implementation.



## 6. Landscaping

The following policies and standards apply to all public and private development in the PDMP area.

- *Policy:* Planting and the use of hardscape help to create places that are memorable, livable and that possess a unique identity and character. Landscapes should reinforce the best aspects of an environment to make it comfortable for the people living or working there. From sunlit plazas to shady tree-covered streets, the importance of landscaping in creating successful places cannot be overestimated. (MD)
- *Standard:* The plant palette should emphasize massing and form rather than individual or small groupings of shrubs and trees. It should include a mixture of deciduous and evergreen species. (MD)
- *Standard:* Where possible, plants should be grouped according to their water needs and irrigated separately from other groupings with dissimilar water needs. (MD)
- *Standard:* Landscape designs should consider adjacent site landscaping, either existing or planned, and enhance rather than duplicate the landscaping effort. (MD)
- *Standard:* Shrubs should be selected not only for drought tolerance but also for local climate extremes, for low maintenance characteristics, and for durability. (MD)
- *Standard:* Tree selection and placement should allow for sufficient root space adjacent to paved surfaces. (MD)
- *Standard:* Streetscapes should contain primary trees that provide shade for pedestrians, soften and frame the street and adjacent architecture and define public open space. (MD)
- *Standard:* Accent trees should be used to define entrances, add variety in form and color and highlight other focal points. (MD)
- *Standard:* Alleys in residential areas should also have tree plantings in scale with the smaller available space. Alleys should not appear barren and devoid of vegetation. (MD)
- *Standard:* Plantings at intersections and driveways should be located to maintain safe sight line distances. (MD)
- *Standard:* Shrub plantings should soften and enhance building massing with a varied layering of forms, color and texture. (MD)

## 7. Signage

- *Policy:* All signage within the PDMP area shall be consistent with a City approved Sign Program.
- *Standard:* Entry signage should be an integral part of the pedestrian experience and provide guidance for vehicular traffic.
- *Standard:* Entry signage may be used as a formal statement into a business park, commercial area, residential development or public space. (MD)
- *Standard:* Signage construction may be incorporated into a wall or fence or as an independent structure located behind the landscape corridor adjacent to a street. It must be placed so as to not interfere with important vehicular lines of sight. (MD)
- *Standard:* Construction materials should match or complement the aesthetic design of nearby walls, fences and/or building architecture. (MD)

- *Standard:* Signage dimensions should be in scale with the surrounding environment and for its purpose, (e.g., to identify project name). (MD)
- *Standard:* Landscaping around signs may serve as backdrops to and highlight the signage. Landscaping also may bring attention to the signage such as with the use of seasonal, colorful, annual plantings. (MD)

Refer to *Vallejo Waterfront Design Guidelines Section A. Guidelines for All Districts* and individual District Sections

## 8. Street Furnishings and Public Art

- *Policy:* All street program furnishings should be consistent with the *Vallejo Waterfront Design Guidelines*. All public art should be consistent with a City-approved Public Art Program.
- Adopt a “percent for art” program within one year of approval of the Waterfront Project as a part of a Citywide program. The program should create a centralized fund to ensure that the fees generated by the Waterfront Project are used for public art in the project area. A fee of one percent of the construction cost of the building is recommended for all projects. In addition, the City should designate either the Vallejo Community Arts Foundation or the City's Cultural Arts Commission to be responsible for approving public art projects in the Waterfront Plan Area.

Refer to the *Vallejo Waterfront Design Guidelines Section B. Street Trees, Lighting, and Furnishing* for direction on implementation.

## 9. Project Development Profiles

### 9.1 Northern Waterfront

The Northern Waterfront area extends on the western side of Mare Island Way between the Yacht Club at the southern end to the Mare Island Causeway at the northern end.

#### 9.1.1 Private Development

Existing development in this section remains. The new development includes:

- Parcel A: This residential area is known as Mariner’s Cove. It is proposed to include up to 175 dwelling units on a 10.8 acre parcel with the 4.0 acre Wetland Park located between its northern and southern residential neighborhoods, to be constructed northeast of a realigned Harbor Way.
- Parcel B: This parcel is proposed to have up to 12,000 gross square feet of retail commercial development that is oriented to the waterfront.
- Parcel C: This parcel is proposed to have up to 10,000 gross square feet of retail commercial development that is oriented to the waterfront and is anticipated to include a restaurant.

### **9.1.2 Public Spaces<sup>3</sup>**

The Northern Waterfront area is different in character than the Central Waterfront area. The most obvious difference is the presence of the marina facilities at the Yacht Club and Municipal Marina. These facilities lend a distinctively maritime character to the waterfront. The public spaces in this section would take advantage of this character by the proposed widening of the promenade and by creating a continuous green space parallel along the water's edge. A 3.5-acre public park (Promenade Park) is proposed to be constructed adjacent to the water's edge west of the realigned Harbor Way. Landscaped courts and passages would extend into the residential and mixed-use areas to engage the development with the waterfront. The Harbor Master's office, two restaurants and all existing commercial and marine related uses north of the Harbor Master's office will remain.

At the intersection of Tennessee Street and Mare Island Way, a "gateway" feature is envisioned to be located to announce one's arrival into the waterfront area.

A Developer constructed, 4.0 acre public Wetland Park will be located in the middle of the two Northern Waterfront neighborhoods. This 4.0 acre park will bring the total open space to 7.5 acres and it will be maintained by the City of Vallejo. (S.A. 2006)

## **9.2 Central Waterfront**

The Central Waterfront area is centered around the completed extension of Georgia Street from the mid-200 block to Mare Island Way at the Ferry Terminal. The Central Waterfront is the heart of the planning area. This area generally extends between the Capitol Street extension, Mare Island Strait, Maine Street and Santa Clara Street. In addition to the recently completed extension of Georgia Street, this portion of the plan area encompasses two additional primary components of the plan: the Vallejo Station Multimodal Waterfront Transportation Facility and the Civic Center.

### **9.2.1 Vallejo Station Concept: Public/Private Partnership**

Vallejo Station is a proposed multimodal waterfront transportation facility intended to create the principal transit hub serving the City of Vallejo as well as providing a gateway to the North Bay and Solano County. It includes the construction of a parking garage to provide ferry parking for existing and future ferry service from the Vallejo Ferry Terminal; bus transfer facilities to connect local and regional bus services to each other and the ferry (both in the Transit Center to the east of Santa Clara Street and along Mare Island Way); intensive transit-supportive commercial and residential development around and near the bus and ferry service facilities; and several public open space and urban design enhancements to connect the various components of Vallejo Station with the Ferry Terminal and downtown.

The Vallejo Station concept includes three primary features in its development: 1) transportation elements, 2) transit-supportive private sector investments, and 3) public open space and urban design enhancements.



## 1. Vallejo Station Transportation Elements under the Waterfront Project

- **Parking Garage:** A central element of Vallejo Station is a public parking garage structure (Parcel L), which would be located across Mare Island Way from the existing Ferry Terminal. The garage would provide two levels containing 1,190 ferry patron-parking stalls to meet the projected demand for ferry parking under a three-boat in-service plan to be implemented in 2006. The garage would also form the nucleus of a transit village on the waterfront, containing additional parking for Vallejo Station transit-supportive private sector investments of multi-family and commercial development, and allow for the development of approximately 11 acres in the Waterfront Project area that are currently used for surface parking. Set into the hillside between Mare Island Way and Santa Clara Street, this area is presently occupied by the U.S. Post Office and restaurant (My Café). These uses are anticipated to be acquired for the project. The Vallejo Station parking garage would have direct access to a pair of signalized pedestrian crosswalks connecting to the Ferry Terminal and regional bus stops. Total covered off-street parking for Vallejo Station and its related private elements would amount to approximately 1,868 spaces.
- **Bus Facilities:** Regional and local bus services fanning out from Downtown Vallejo currently carry about 12,000 daily riders, or nearly 3.5 million annual passengers. BartLink buses to El Cerrito Del Norte BART carry 2,000 passengers per weekday. VINE express buses to the Napa Valley carry 800 daily riders and Benicia Transit to Benicia and Pleasant Hill BART serve more than 500 daily riders. Vallejo Transit's local bus routes carry approximately 8,000 daily passengers. Patronage on all bus services that would connect at Vallejo Station is projected to grow to more than 11,000 daily passenger movements on a typical weekday by all modes upon project completion.

Vallejo Station bus facilities are intended to include significant improvements to the interface between Vallejo Bay Link ferryboats and buses. A new off-street bus transfer facility to replace the current on-street condition at Marin and York Streets is planned to be constructed between Sacramento and Santa Clara Streets as an extension of York Street (Parcel O) within walking distance of the ferry dock. The integration of local routes and regional express bus service with the proposed parking garage and existing Ferry Terminal is intended to make Vallejo Station the most important focus of bus service in the North Bay.

The off-street design of the new bus transfer facility is planned to be integrated with downtown uses and to minimize the loss of on-street parking. It is intended that patrons benefit from upgraded amenities providing a convenient and safe transit experience. The off-street bus transfer facility would provide up to 12 bus bays, integrating passenger waiting areas that incorporate weather protection, seating, lighting, security features and street trees for visual enhancement. A transit office building would ultimately be developed as an integral part of the bus transfer facility. The office building would contain pass/ticket sales facilities and a public information booth, along with bus driver layover/relief facilities. The bus transfer facility design is planned to meet the Americans with Disabilities Act standards and State Transportation Guidelines for Challenged Patrons.

Regional express bus stops would remain on Mare Island Way, immediately adjacent to the Ferry Terminal (up to 10 bus bays). However, loading areas would be expanded and a system of walkways and plazas would connect the parking structure and local bus transfer facility together. A new drop-off/pick-up area would be developed to serve private autos and employer shuttles. Local bus transit service to Mare Island would connect with the existing Ferry Terminal and the new downtown bus transfer facility.

- **Pedestrian facilities:** As part of the Vallejo Station Plan, strong east-west pedestrian linkages include walkways along the Georgia Street Extension and a second pedestrian connection through the Paseo Park, both linking the Ferry Terminal area along Mare Island Way with the Bus Transfer Center just east of Santa Clara Street.

## 2. Vallejo Station Transit-Supportive Private Sector Investments

Various transit-supportive private sector land uses such as live-work units will include a hotel, restaurant, conference center (Parcel L4), residential units (Parcel L1) and a restaurant with outdoor dining (Parcel L2), taking advantage of scenic views to the Mare Island Strait. These uses, built on top of the Vallejo Station parking garage (Parcel L3), will have ground-floor retail fronting Santa Clara and Georgia Streets (Parcel L4). Retail space would be incorporated at the sidewalk/ground floor level with a residential condominium development elevated above the street immediately south of the Vallejo Station parking garage fronting Maine Street and Mare Island Way. A retail/office project is planned adjacent to the parking garage fronting Georgia Street and Mare Island Way. All development surrounding the ferry parking garage structure would have dedicated underground parking with separate entrances from the ferry parking portion of the garage. The development on top of the ferry parking garage would look into a landscaped paseo over the garage. The construction of office, retail and hotel development for Vallejo Station is planned to commence after the underground ferry parking structure is completed.

The most intensive private urban development within the PDMP area is within the Central Waterfront area; however, this development is primarily located on the eastern side of Mare Island Way. With the exception of the Ferry Terminal and related improvements, existing development on the west side of Mare Island Way is ultimately removed. On the eastside, the existing Post Office, restaurant and surface ferry parking lots are removed. Marina Vista Park was removed as a result of the Capitol Street extension and the need to accommodate ferry parking that was eliminated by the development of the State Farm Claims Center.

New private development in the Central Waterfront area, by parcel, is summarized below:

- *Parcel J:*

This parcel will contain up to 286 stacked flat residential condominium dwellings, up to four levels built on top of a one level parking garage, potentially half above and half below-grade. Dwellings will contain between one and three bedrooms averaging 1,050 square feet. Garage parking will provide up to 516 spaces. The residential development will also include on-site landscaping in courtyards and perimeter landscaping.

Retail uses on the ground-floor, up to 25,000 square feet, are required uses for the building on Parcel J1 as defined and allowed in Table 3. (S.A. 2006)

A three-level parking lot with 600 spaces will also be constructed immediately east of Parcel J on the existing City Hall surface parking lot. The structure will be constructed with one level of parking below the existing grade of Santa Clara Street and the second level approximately 12 feet above Santa Clara Street. The garage will be constructed in two phases; the first phase includes the two lower levels providing 400 spaces to replace existing City Hall parking; the second phase consists of a third level of parking to contain 200 spaces for future ferry service parking if a fourth ferry is brought into service.

- *Parcel L:*

Parcel L will be developed with residential dwelling units, retail commercial and office space, a hotel, restaurant and a conference center. Parking for these uses and for ferry riders of up to 1,868 parking spaces will be primarily located in multiple structured parking garages located on Parcels L1, L2, L3, and L5. A neighborhood Paseo Park (consisting of approximately 0.5 acres) will provide a pedestrian access way through the site linking the Bus Transfer Center and downtown area to the east, with the Ferry Terminal. The paseo will include approximately 50 surface parking spaces.

It is possible that the parking garage could be built in two phases, the first would consist of a 3-story parking structure located on Parcel L3 and L5, at ground-level with Santa Clara Street, with two additional levels below. During the interim Phase 1, the ground-level would contain approximately 250 parking spaces and a minimum 18-foot pedestrian path connecting Santa Clara Street and the Bus Transfer Center with Mare Island Way and the ferry and bus services. The ultimate development of the parking garage will implement Phase 2, which would remove 250 parking spaces at ground-level available to ferry patrons to construct the Paseo Park. The Paseo Park would also include pedestrian connections linking Santa Clara Street and the Bus Transfer Center with Mare Island Way and the ferry and bus services as well as open space amenities and a total of 50 short-term parking spaces, which may be constructed in two phases. The City shall delay installation of the planned northern row of parking along the Paseo Park until, in the City's determination, the conference center or other uses in Zone Two (the same zone as the conference center) require such additional parking spaces. The City shall be responsible for the costs of installing such future parking spaces. These improvements are located on Parcel L5. In the interim, landscaping will be provided within this space as defined in the *Vallejo Waterfront Design Guidelines* (Refer to *Vallejo Waterfront Design Guidelines Section III. C.2.1.2 Vallejo Station Paseo Park (Area F)* and Figures 3.C.23 to 3.C.25).

- *Parcel O:*

Parcel O accommodates a 10,000 square foot regional bus transit facility and associated parking.

### 3. Public Open Space and Urban Design Enhancements

Open Space and Urban Design Enhancements are planned in conjunction with the Vallejo Station transportation improvements and transit-supportive private sector investments.

As part of the Vallejo Station Plan, strong east-west pedestrian linkages include walkways along the Georgia Street Extension and a second pedestrian connection through the Paseo Park, both linking the Ferry Terminal area along Mare Island Way with the Bus Transfer Center, just east of Santa Clara Street.

A Paseo Park (Parcel L5) is planned to orient on a central axis through Vallejo Station (Parcel L3), providing a pedestrian-oriented environment linking the various Vallejo Station transportation elements terminating at the Ferry Terminal adjacent to the Festival Green open space at the waterfront. The Paseo Park would be located above the parking structure and along the proposed Hotel/Conference Center (Parcel L4) and condominium development (Parcel L1). The Paseo Park would be landscaped with trees and pedestrian-scale lighting. The neighborhood Paseo Park would include a pedestrian way. Stoops, stairs, residential entrances and lobbies to activate the area would front the Paseo Park. A narrow and low-speed drive aisle would provide access to residential and visitor parking on one side of the drive, and potentially on both sides, as well as emergency vehicle access. Pedestrian walkways, sidewalks and crosswalks are intended to provide direct connections between the bus transfer facilities, ferry parking garage and Ferry Terminal, integrating these Vallejo Station elements together. Bicycle access and storage is also intended to be included in the Vallejo Station project. Vallejo Station is being

designed to integrate street furniture with downtown urban design improvements along the Georgia Street Extension axis, through the Paseo Park, and along Mare Island Way. Streetscape enhancements would be developed in conjunction with the new local Bus Transfer Center that would enhance the facility’s visibility. Expanded street parking would also be provided along existing and new area roadways.

### 9.2.2 Public Spaces<sup>4</sup>

The Central Waterfront area includes the more structured parts of the waterfront where the seawall extends to either side of the Ferry Terminal to the Yacht Club at the north end and the boat basin at the southern end. The terminus of the Georgia Street extension is at the Ferry Terminal area, and the major public spaces for the waterfront are centered within this area.

The Festival Green will be located at the intersection of Georgia Street and Mare Island Way in the largest triangular open space that extends into the developed edge. The Festival Green is proposed to be split into two sections by Mare Island Way with a larger area on the western side and a smaller triangle on the eastern side. Mare Island Way can be closed in this area to allow the Festival Green to be used as one large pedestrian space. On the eastern end of the Festival Green, Dr. Martin Luther King Jr. Unity Plaza serves the same function. This plaza extends up Georgia Street across Santa Clara Street into the downtown. The plaza uses a consistent paving in the street sections to create a pedestrian space when the streets are closed for events; it also includes decorative paving replicating the historic shoreline area and similar features.

Flanking the north side of the western end of the Festival Green is a large open green space running parallel with the water’s edge. This space is flexible in use and can accommodate a wide variety of recreational functions. The south side of Festival Green extension is adjacent to the Ferry Terminal.

## 9.3 Southern Waterfront

The Southern Waterfront District extends from the water’s edge to Sonoma Boulevard in the east and is bounded on its other sides by Mare Island Way and Curtola Parkway to the north and Sonoma Avenue to the south.

### 9.3.1 Private Development

Existing development in the west of Mare Island Way and Sonoma Boulevard ultimately is removed. All other existing development in this section remains.

- Parcels S and T: The development is proposed to be mixed use with a maximum of 170,000 gross square feet of commercial, office and/or light industrial and 650 higher-density residential units.

### 9.3.2 Public Spaces<sup>5</sup>

The Southern Waterfront area is also very different in character from both the Central and Northern Waterfront areas. The Southern Waterfront edge is more natural; the waterfront promenade is proposed to be less structured, and 10.9 acres of parks and open space is proposed to provide recreational opportunities for the community and adjacent development. A small docking facility would remain at the reconfigured former boat launch site. Visual and physical access between the downtown and waterfront is proposed to be provided with the extension of Marin Street where feasible.

As with the Northern Waterfront, a gateway feature is envisioned to be located at the intersection of Sonoma Boulevard and Curtola Parkway to define the southern end of the waterfront area and to announce its entrance.

**Table 1  
Parcel Development Profiles – The Waterfront Project**

<b>Parcel A</b>	
<b>Parcel Size</b>	14.8 acres
<b>Parcel Location</b>	South of Mare Island Causeway, west of the realigned Harbor Way, north of Mare Island Way
<b>Max. Building Height</b>	Heights of the residential buildings shall not exceed 45 feet in the Northern Residential Neighborhood and 38 feet in the Southern Residential Neighborhood.
<b>Development Profile</b>	Up to 175 dwelling units on 10.8 acres and a 4 acre Wetland Park centrally located between the two residential neighborhoods.
<b>Parcel B-1, B-2</b>	
<b>Parcel Size</b>	B-1 building pad of 0.7 acre and B-2 building pad of 0.4 acre, parking per the City of Vallejo zoning code will be provided
<b>Parcel Location</b>	West of Harbor Way and east of Municipal Marina
<b>Max. Building Height</b>	25 feet
<b>Development Profile</b>	Up to 12,000 gross square feet of single-story waterfront-oriented commercial/retail space, plus parking
<b>Parcel C</b>	
<b>Parcel Size</b>	C building pad of 0.5 acre, parking per the City of Vallejo zoning code will be provided
<b>Parcel Location</b>	Southwest corner of Harbor Way and Mare Island Way
<b>Max. Building Height</b>	25 feet
<b>Development Profile</b>	Up to 10,000 gross square feet of single-story waterfront-oriented commercial/retail space, potentially including restaurants, plus parking
<b>Parcel J</b>	
<b>Parcel Size</b>	9.3 acres
<b>Parcel Location</b>	East of Mare Island Way between the Georgia and Capitol Street extensions, west of Civic Center Drive
<b>Max. Building Height</b>	Maximum height of the building on Parcel J1 is 45 feet along Mare Island Way and the Festival Green for a minimum depth of 30 feet, with the remainder of the building to be limited to a height of 55 feet. Maximum height of the building on Parcel J2 is 45 feet along Mare Island Way to Capitol Street for a minimum depth of 30 feet, with the remainder of such building to be limited to a maximum height of 55 feet.
<b>Development Profile</b>	<p>Up to 286 stacked flat residential condominium dwellings up to four levels built on top of one level parking garage, potentially half above and half below-grade. Dwellings will contain between one and three bedrooms averaging 1,050 square feet. Garage parking will provide up to 516 spaces. The residential development will also include on-site landscaping in courtyards and perimeter landscaping. Retail uses on the ground floor up to 25,000 square feet are required of the building on Parcel J1 as defined and allowed in Table 3: Permitted and Conditional Land Uses – Commercial and Industrial Types.</p> <p>Civic Center Drive: 0.9-acre roadway<sup>6</sup></p> <p>Capitol Street Extension: 0.8-acre roadway (potentially)</p> <p>Festival Green: 0.9-acre open space</p>

<b>Table 1 Parcel Development Profiles – The Waterfront Project</b>	
<b>Parcels S and T</b>	
<b>Parcel Size</b>	41.5 acres
<b>Parcel Location</b>	West of Sonoma Boulevard and Mare Island Way, east of the waterfront
<b>Max. Building Height</b>	Parcel T1: 55 feet Parcels S, T2, and T3: 45 feet
<b>Development Profile</b>	Parcel T1: 14.9 acres. Three buildings with a total of 650 stacked flat residential condominium units  Parcels S, T2, and T3: 11.5 acres. Approximately 170,000 square feet of one- and two-story retail/commercial, office, and flex space/light industrial uses including the relocated U.S. Post Office  The development of Parcels S and T includes the extension of Marin Street from Curtola Parkway along the waterfront to an intersection with the extension of Solano Avenue.  Southern Waterfront Open Space: 10.9 acres on the waterfront
<b>Parks &amp; Open Space (Parcels P/OS)</b>	
<b>Parcel Size</b>	Total approximately 35.0 acres, of which about 29.0 acres would be newly developed or newly designated
<b>Parcel Location</b>	Along the waterfront west of Mare Island Way, Harbor Way, and the Marin Street extension, between the Solano Avenue extension on the south and Mare Island Causeway on the north, with the exception of three parcels east of the waterfront roadways: 0.4 acres of Martin Luther King Jr. Unity Plaza Extension; and 0.9 acres of Festival Green
<b>Max. Building Height</b>	N/A
<b>Development Profile</b>	Public parks/open space includes landscaping, lighting, sculptures, pedestrian waterfront promenade additions at Mariner’s Cove, Service Club Park, Festival Green, Martin Luther King Jr. Unity Plaza, Independence Park, Wetland Park; and boat launch and public amenities in the Southern Waterfront.

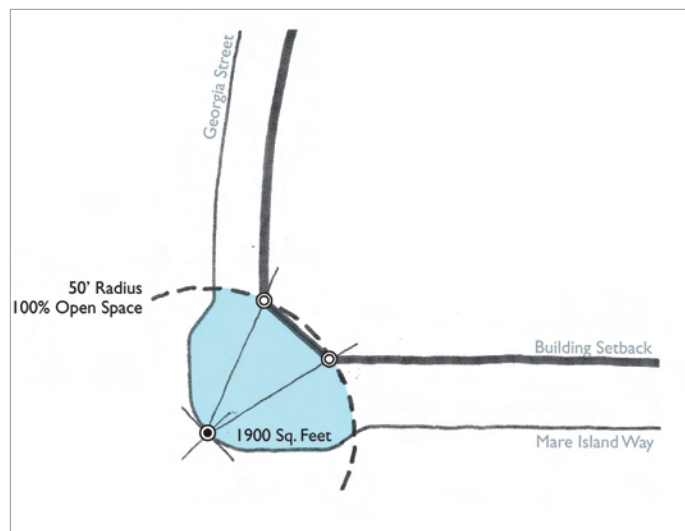

Figure H: Corner Plaza Diagram, Mare Island Way & Georgia Street (S.A. 2006)





Table 2 Parcel Development Profiles – The Vallejo Station Project	
Parcel L	
<b>Parcel Size</b>	8.4 acres
<b>Parcel Location</b>	Between Mare Island Way and Santa Clara Street, Maine Street and the Georgia Street extension
<b>Max. Building Height</b>	<p>Building heights shall be established in relation to specific zones of Parcel L, including the street frontages of Mare Island Way, Maine Street, Georgia Street, and Santa Clara Street. The locations from which the height of buildings along each block (e.g., along Mare Island Way from Georgia Street to Maine Street) will be measured are depicted in Figures D, E and F.</p> <p><i>Parcel L1:</i></p> <p>(a) Along Mare Island Way, Parcel L1 shall be divided into two zones:</p> <p>(i) L1 Zone One is located along Mare Island Way, originating at Maine Street, includes the corner of Maine and Mare Island Way, and has a building frontage along Mare Island Way of approximately 265 feet and shall be limited to a maximum height of 45 feet for a depth of one dwelling unit (i.e., a minimum of 30 feet).</p> <p>(ii) Zone Two is located north of Zone One and south of the Vallejo Station parking garage entrance, and shall be limited to a maximum height of 35 feet.</p> <p>(b) Along Maine Street, Parcel L1 shall be divided into three zones:</p> <p>(i) Zone One originates on the west segment of Maine Street, approximately 50 feet from the curb of Mare Island Way, and shall be limited to a maximum height of 55 feet.</p> <p>(ii) Zone Two is located east of Zone One for approximately 150 feet, and shall be limited to a maximum height of 65 feet.</p> <p>(iii) Zone Three is located east of Zone Two up to the corner of Maine Street and Santa Clara Street, and shall be limited to a maximum height of 70 feet.</p> <p>(c) Along the Vallejo Station Paseo, Parcel L1 shall be limited to a maximum height of 65 feet,</p> <p>(d) The building at the corner of the Vallejo Station Paseo (Parcel L5) and Santa Clara Street shall not exceed 60 feet as depicted in Figure E.</p> <p><i>Parcel L2:</i> shall be limited to a maximum height of 45 feet.</p> <p><i>Parcel L4:</i> shall be limited to a maximum height of 55 feet.</p>



**Table 2  
Parcel Development Profiles – The Vallejo Station Project**

<b>Development Profile</b>	<p>Residential, commercial/office, parking garage, and park space:</p> <ul style="list-style-type: none"> <li>- up to 140 residential units.</li> <li>- up to 102,000 gross square feet retail/commercial and office space.</li> <li>- up to 200,000 square feet of commercial uses for a 200 room hotel, restaurant, and conference center.</li> <li>- up to 1,868 parking spaces.</li> </ul> <p><i>Parcel L1:</i> a 1.9-acre parcel developed with up to 140 single-family residential condominium units in a two- to five-story structure over two levels of parking (241 spaces) and up to 12,000 gross square feet of retail commercial space.</p> <p>At the corner of Mare Island Way and Georgia Street, a setback of the building shall be provided to create a public open space plaza of no less than 1,900 square feet, as depicted in Figure H, which may include outdoor seating.</p> <p><i>Parcel L2:</i> a 1.9-acre parcel developed with approximately 63,000 gross square feet of office/commercial space in a two- and three-story structure over a single-level parking garage (215 spaces).</p> <p>On Parcel L2, retail uses on the ground floor of the building as defined and allowed in Table 3: Permitted Uses.</p> <p><i>Parcel L3:</i> a 4.6-acre parcel providing a two-level Ferry Parking Garage with 1,190 parking spaces reserved for the ferry and Performing Arts Center patrons.</p> <p><i>Parcel L4:</i> a 2.8 acre vertical subdivision private development parcel on the top level of the L3 garage structure developed in two and four story building with approximately 25,000 square feet of first floor retail/commercial uses fronting on Georgia and Santa Clara Streets. The 200,000 square foot, 200-room hotel located on the second to fourth floors will include a two-level 32,000 square foot, two-story restaurant and meeting center facility. Parking for 172 cars will be provided on the first and second levels of the private development structure to serve the retail, hotel, restaurant, and meeting center uses.</p> <p><i>Parcel L5:</i> a 1.40 acre vertical subdivision public development parcel on the top level of the L3 garage structure. This parcel will be developed with a public open space paseo providing pedestrian access between the Bus Transfer Center on Parcel O and the Ferry Terminal as well as public open space serving the Vallejo Station project and downtown area. The parcel will provide an access driveway from Santa Clara Street including 50 short term parking spaces to serve the retail and restaurant uses. The driveway will also provide emergency fire service access for the benefit of Parcels L2 and L4.</p> <p><i>Park Spaces:</i> neighborhood Paseo Park, (approximately 0.5 new acres). Parcel L5 would include a pedestrian access way through the site from the Bus Transfer Center to the Ferry Terminal at the waterfront, with open space amenities and landscaping.</p>
<b>Parcel O</b>	
<b>Parcel Size</b>	0.9 acres
<b>Parcel Location</b>	Portion of 6.2-acre area bounded by Santa Clara, Sacramento, Maine, and Georgia Streets
<b>Max. Building Height</b>	50 feet
<b>Development Profile</b>	Bus Transfer Center. Includes 10,000 gross square feet of public transit office floor area and associated parking.

Table 3

## Permitted and Conditional Land Uses – Commercial and Industrial Types

Commercial Land Uses	Parcels B & C	Parcels J1 (Frontage on Festival Green) & Parcel L2	Parcels L1 & L4	Parcel S	Parcels T2 & T3
Administrative & professional services	MJUP	--	P	P	P
Animal sales & service – Retail sales, grooming & veterinary (small animals)	--	P (6)	P (6)	--	--
Building maintenance services	--	--	--	--	P
Business equipment sales & services	--	--	P	--	P
Business support services	--	--	P	--	P
Communication services	--	--	P	--	P
Construction sales and services	--	--	--	--	P (11)
Convenience sales and personal services (e.g., drug stores and convenience markets less than 5,000 square feet in size)	--	P (2), (3), (6)	P (2), (3), (6)	P (2), (3), (6)	--
Eating and drinking establishments	P (2)	P (2), (3), (4)	P (2), (3), (4)	P (2), (3), (4)	--
Quick-service/take out	P (2)(7)	MNUP (2), (3), (4), (7)	MNUP (2), (3), (4), (7)	--	--
Financial, insurance and real estate services	--	P (1), (2)	P (2)	P (2)	P (2)

**Table 3**

**Permitted and Conditional Land Uses – Commercial and Industrial Types**

Commercial Land Uses	Parcels B & C	Parcels J1 (Frontage on Festival Green) & Parcel L2	Parcels L1 & L4	Parcel S	Parcels T2 & T3
<b>Food and beverage retail sales</b>					
11,000 square feet and under	--	P (2), (3), (6)	P (2), (3), (6)	--	--
Greater than 11,000 square feet	--	MJUP (2), (3), (6)	MJUP (2), (3), (6)	--	--
Fast food/take out	--	MNUP (2), (3), (6), (7)	MNUP (2), (3), (6), (7)	--	--
Laundry services	--	--	MNUP	--	--
Medical offices	--	--	--	P	--
Medical services	--	--	--	P	--
Parking facilities (f) *	P	--	MJUP (1)	P	--
<b>Participant sports and recreation</b>					
Indoor (e.g., includes health and fitness clubs)	--	--	MNUP (3)	--	MNUP (3)
Bingo	--	--	MNUP (1), (3)	--	--
<b>Personal services</b>					
General	--	P	P	--	--
Functional community training for developmentally disabled	--	--	MNUP (1)	--	--
Repair services, consumer	P	--	P	--	P
Research services	--	--	--	--	P



<b>Table 3</b>					
<b>Permitted and Conditional Land Uses – Commercial and Industrial Types</b>					
<b>Commercial Land Uses</b>	<b>Parcels B &amp; C</b>	<b>Parcels J1 (Frontage on Festival Green) &amp; Parcel L2</b>	<b>Parcels L1 &amp; L4</b>	<b>Parcel S</b>	<b>Parcels T2 &amp; T3</b>
<b>Retail sales</b>					
<b>General</b>	P <sup>s</sup> (2), (3), (6), (7)	P (2), (3), (6), (7)	P (2), (3), (6), (7)	P (2), (3), (5), (6), (7)	P (2), (3), (6), (7)
<b>Spectator sports and entertainment (e.g., includes theaters, cabarets, performing art studios, galleries)</b>					
<b>Limited</b>	--	MNUP (3)	MNUP (3)	--	--
<b>General</b>	--	MNUP (3)	MNUP (3)	--	--
<b>Transient habitation</b>					
<b>Lodging (e.g., hotel, motel,</b>	--	P (3), (4)	P (3), (4)	--	--
<b>Bed &amp; Breakfast)</b>	--	P (3), (4)	P (3), (4)	--	--

Table 3

## Permitted and Conditional Land Uses – Commercial and Industrial Types

Industrial Land Uses	Parcels B & C	Parcels J1 (Frontage on Festival Green) & Parcel L2	Parcels L1 & L4	Parcel S	Parcels T2 & T3
Custom manufacturing (e.g., includes bakeries)	--	--	--	--	MNUP
Food and Beverage Processing					
Beer and Wine Manufacturing	--	--	--	--	MNUP
Beer and Wine Manufacturing with on-site tasting room	--	--	--	--	MJUP (3)
General industrial	--	--	--	--	MNUP
Packing and processing	--	--	--	--	MNUP
Civic Land Uses	Parcels B & C	Parcels J1 (Frontage on Festival Green) & Parcel L2	Parcels L1 & L4	Parcel S	Parcels T2 & T3
Administrative services	--			--	P
Cultural exhibits	P	--	--	--	--
Essential services	P	--	--	P	P
Parking services	P	P	P	--	P
Public park & open space	P	--	--	--	P
Postal services	--	P (11)	--	--	P
Telecommunication facility		--	--	MNUP	MNUP
Accessory and Temporary Land Uses	Parcels B & C	Parcels J1 (Frontage on Festival Green) & Parcel L2	Parcels L1 & L4	Parcel S	Parcels T2 & T3
Accessory uses (See VMC Section 16.58.040 for list of accessory uses)	P per VMC Section 16.58.040	P per VMC Section 16.58.040	P per VMC Section 16.58.040	P per VMC Section 16.58.040	P per VMC Section 16.58.040

**Table 3  
Permitted and Conditional Land Uses – Commercial and Industrial Types**

	Land Use or Use Condition	Conditions, Limitations or Prohibitions
(1)	Location limits for specific land use classifications	<p>Georgia Street Corridor: Use classification(s) prohibited on street or ground floor level with the exception of banks, credit unions and automatic teller machines (ATM) permitted on ground floor level.</p> <p>Central Downtown: Use classification(s) prohibited on the street or ground floor level with the following exceptions:</p> <ul style="list-style-type: none"> <li>• Permitted on ground floor level along Santa Clara Street, Maine Street frontages</li> <li>• Banks, credit unions and automatic teller machines (ATM) permitted on ground floor level.</li> </ul>
(2)	Drive-through (a)*	Prohibited
(3)	Liquor (alcohol) sales	<p>Subject to the restrictions and limitations of VMC Sections 16.82.060Q (On-sale liquor establishments) and 16.82.060R (Off-sale liquor establishments).</p> <p>Tasting rooms, beer and wine manufacturing with on-site tasting rooms, and brewpubs are exempt from the one-thousand foot restriction contained in VMC Section 16.82.060 Q (12), except that the combined number of stand-alone tasting rooms and brewpubs shall not</p>
(4)	Outdoor dining (b)*	<p>Permitted subject to the following:</p> <ul style="list-style-type: none"> <li>• Approval of an Administrative Permit (AP).</li> <li>• Approval of an Encroachment Permit if conducted within the public right-of-way.</li> <li>• Securing a general liability insurance policy naming the City as additional insured if conducted within the public right-of-way.</li> <li>• Subject to Development Standards in Section III.A.2.3.3 Detailed Design of Outdoor Dining and Display, Section III.A.2.2.4 Outdoor Recreation, Dining and Display, and Section III.C.3.1.6 Outdoor Recreation, Dining and Display of the Vallejo Waterfront Design Guidelines.</li> </ul>
(5)	Outdoor display (c)*	Permitted with an Administrative Permit subject to the regulations set forth in VMC Chapter 16.77.

Table 3

## Permitted and Conditional Land Uses – Commercial and Industrial Types

	Land Use or Use Condition	Conditions, Limitations or Prohibitions
(6)	Outdoor street vending (d)*	Permitted, subject to the following: <ul style="list-style-type: none"> <li>• Approval of an Administrative Permit (AP).</li> <li>• Approval of an Encroachment Permit if conducted within the public right-of-way.</li> <li>• Securing a general liability insurance policy naming the City as additional insured if conducted within the public right-of-way.</li> <li>• Subject to Development Standards in Section III.A.2.3.3 Detailed Design of Outdoor Dining and Display, Section III.A.2.2.4 Outdoor Recreation, Dining and Display, and Section III.C.3.1.6 Outdoor Recreation, Dining and Display of the Vallejo Waterfront Design Guidelines.</li> </ul>
(7)	Quick-service/take-out (e)*	Permitted if less than 2,500 square feet of gross floor area. Subject to a Minor Use Permit (MNUP) if 2,500 square feet of gross floor area or more.
(8)	Automotive & equipment	Limited to automotive and equipment sales and display.
(9)	Parking	Limited to parking only.
(10)	Storage	No on-site storage or business activities.
(11)	Postal Services	Retail only.
* See Table Definitions of Terms		



Definitions of Terms		
(a)	Drive-through	A place of business that is designed to include a service window or drive-through facility that is accessible by vehicle
(b)	Outdoor dining	The operation of dining service located outside of and ancillary to an eating and drinking establishment. Outdoor dining includes the placement of tables, chairs and similar furniture, where seating does not exceed 25% of the indoor seating area of the eating and drinking establishment.
(c)	Outdoor display	The placement of goods or merchandise outdoors of a business or use, without the benefit of screening or fencing. The goods and merchandise that are displayed is representative of the goods and merchandise offered for sale by the associated business or use operating inside a building. Outdoor display does not include the outdoor storage of goods or merchandise that is screened or fenced.
(d)	Outdoor street vending	A business that provides the sale of food, beverage and other general retail sale items in an open area or from a freestanding kiosk or small covered structure placed on the sidewalk or in the public right-of-way.
(e)	Quick-service/take-out	An eating and drinking establishment or a food and beverage retail sales establishment where:  - More than 50% of the food, frozen desserts, and/or beverages intended for immediate consumption is available upon a short waiting time, and is packed or presented in such a manner that it may be readily consumed off of the premises, as well as on the premises where it is sold  - There are no facilities for on-site consumption (seating), or where such facilities are limited or insufficient for the volume of customers purchasing such items.
(f)	Parking facilities, public or private	Any public or private land designed to be used for parking vehicles including, but not limited to lots and garages, as a principal use and not accessory or ancillary to a permitted or conditional use. This definition does not apply to parking facilities that are ancillary or supportive to another principal land use contained on the subject property.

#### LEGEND

- P = Permitted  
MJUP = Major Use Permit Required  
MNUP = Minor Use Permit Required  
-- = Not Permitted  
(1) = Land Use Condition, Limitations or Prohibitions  
(a) = Definition

(Endnotes)

<sup>1</sup> See Section 5.1 Circulation, of the PDMP, regarding required study of the need for connection of Civic Center Drive to Georgia Street.

<sup>2</sup> See Section 5.1 Circulation, of the PDMP, regarding required study of the need for connection of Civic Center Drive to Georgia Street.

<sup>3</sup> The text in this section is text amended from text taken from WRT's Public Spaces Plan, pages 8-9.

<sup>4</sup> The text in this section is amended from text taken from WRT's Public Spaces Plan, pages 5-7.

<sup>5</sup> The text in this section is amended from text taken from WRT's Public Spaces Plan, pages 10-11.

<sup>6</sup> See Section 5.1 Circulation, of the PDMP, regarding required study of the need for connection of Civic Center Drive to Georgia Street.

<sup>7</sup> Land use designations derived from Table 8.1 Permitted and Conditional Land Uses of the Downtown Vallejo Specific Plan dated September 20, 2005.

<sup>8</sup> Water-serving uses will be given highest priority.

(WRT) = Wallace, Roberts & Todd

(MD) = Master Developer

(S.A. 2006) = Executed Settlement Agreement between Waterfront Coalition, City of Vallejo Redevelopment Agency, and Callahan DeSilva, LLC, in December 2006.

This Page Intentionally Left Blank



# ***Vallejo Waterfront Design Guidelines***



# I. Introduction

These Guidelines have been developed in support of the principles and policies of the Vallejo Waterfront Project as defined in the Vallejo Waterfront Planned Development Master Plan (PDMP). In particular, the Guidelines have been developed to support the following objectives and goals from the PDMP that pertain to community planning and urban design:

## *Selected Waterfront Master Plan Objectives*

- To allow the Waterfront and Downtown to regain their historic place as the cultural heart of the community.
- To create quality development and an environment that is pedestrian and transit friendly, and that includes higher density commercial, office and residential uses with innovative public spaces for cultural and recreational activities.

## *Selected Waterfront Master Plan Goals*

- **Transportation Goal** – Revise existing traffic circulation by extending Georgia and Capitol Streets to Mare Island Way to: create marketable properties adjacent to the Waterfront while preserving and enhancing land for public open space; open up the Downtown commercial area to the Waterfront; and increase intersections along Mare Island Way to make it more pedestrian-friendly.
- **Design Character Goal** – Design new development in an architectural style that is compatible with the existing character of the historic Downtown and adjacent residential neighborhoods.
- **Use Goal** – Balance commercial, residential, employment and transportation uses with recreational, festival and events, and other associated uses, so that each are accommodated and each help to create synergy for the Waterfront and Downtown as they function in combination.

To support these goals and objectives these Design Guidelines –

- Build from the Waterfront Plan’s framework of open space, streets, and other design elements that link with the surrounding Downtown and neighborhoods;
- Provide design direction to create a pedestrian-supportive relationship between the public realm of the Waterfront’s sidewalks, parks and plazas, with the private realm of buildings that frame the pedestrian environment, providing additional interest and a sense of security;
- Give careful consideration in the location of land uses and public amenities to create an environment that is dynamic and active throughout the day;
- Ensure the use of high-quality building materials and details for both the architecture and landscape, supporting a Waterfront community character;
- Define the design framework and character of the Waterfront’s parks, open spaces, and streets to create a unified theme for a world-class Waterfront while supporting the community identity of Vallejo, and the unique identity and character of the different Waterfront Districts; and
- Maximize views to the Waterfront and the Mare Island Strait from within the project, the Downtown and the surrounding neighborhoods.



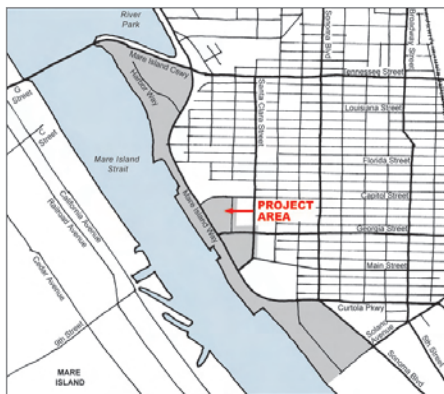

Figure 1.A.1: Location Maps

## A. Applicability and Organization of the Guidelines

### 1. Relationship to Vallejo’s General Plan, Zoning, and Other Policies and Ordinances

The Vallejo Waterfront Design Guidelines (“Design Guidelines”) is an incorporated attachment to the Vallejo Waterfront Planned Development Master Plan (PDMP), that sets forth the policies and standards for land use and design for the Project Area. The Design Guidelines are intended to assist future developers and the City in implementing specific projects in a manner consistent with the PDMP’s land use and design standards. The Design Guidelines have been reviewed and adopted by both the Planning Commission and City Council as part of the approvals process of the Vallejo Waterfront Project. This approval brings the Master Plan and these Design Guidelines into conformance with the City’s General Plan and Zoning Ordinance. In addition, both the PDMP and these Design Guidelines include specific goals, objectives, policies and design concepts from the *City of Vallejo’s Waterfront/Downtown Master Plan for Public Spaces* that was prepared in 2000.

The Guidelines are written to assist City of Vallejo policy makers and City staff in applying the overall and detailed design intent of the Waterfront Plan as they review and approve development proposals that come forward in the future, as well as when they design and implement the public portions of the Waterfront Plan. This document also serves as a guide for project proponents, their designers and engineers, as they design proposals for the development of specific projects.

### 2. Organization of the Design Guidelines Document

There are three main chapters to these Design Guidelines, including this *Chapter I: Introduction*, which gives an overview of the document and lays out the context and general character of the Waterfront both as a whole, and in its individual Districts. The following two chapters contain the main body of the Guidelines; *Chapter II: Unifying Elements and Linkages*, offers Guidelines for public elements that link the Districts with one another and with the surrounding area to create a unified design for the Waterfront area; *Chapter III: Waterfront District Guidelines* contains four sections that guide the overall development of the Waterfront area through its public open space elements, streetscape elements, landscaping and the important gateways into the area. Chapter III provides the Design Guidelines that ensure that development in the Waterfront area is high quality



and results in three Waterfront Districts each having their own unique character. The four sections begin with overall private realm Guidelines that are applicable to all Districts, followed by sections containing Guidelines that will make each of the three Districts unique.

### 3. *Design Principles of the Design Guidelines*

The central organizing principle for the Design Guidelines is that private development in the Waterfront Districts must complement and reinforce the public life in the Waterfront's streets, parks, and open spaces to best achieve the community and urban design goals and objectives of the Waterfront Master Plan. The Guidelines use the terms "public realm" and "private realm" to define these two complementary elements of the Waterfront Master Plan.

#### 3.1 The Public Realm

The public realm includes the community areas within the Waterfront Master Plan area that are mainly in public ownership including streets, sidewalks, parks, open space, plazas and the transit center, whether these areas are maintained publicly or privately. The public realm also includes privately owned and maintained areas that are open to public access most times of the day, and that contribute to public life in Vallejo's Waterfront. Indoor areas of community facilities are not included.

#### 3.2 The Private Realm

The private realm is primarily the area within privately owned buildings, including residential yards and other exterior spaces, that are generally accessible only to residents, businesses, and their guests. The conditions of the private realm that are of most concern to the Guidelines are those that contribute to the life and vitality of the public realm of the Vallejo Waterfront.

Examples include:

- Storefronts, residential and office lobbies, residential yards, fences, walls and other areas that front directly onto sidewalks, parks and open spaces in the public realm;
- Building height, mass, materials, and articulation that have a visual relationship to the public realm; and
- Site access points for pedestrians and vehicles; particularly their relationship to sidewalks and other active areas of the public realm.

### 4. *Construction and Maintenance of the Public Realm*

As defined above, the public realm includes areas that may be built and/or maintained by private and public entities (typically adjacent property owners). The details of this ownership and responsibility for maintenance will be determined through the current negotiations that will likely result in a Landscape, Lighting, and Maintenance District (LLMD) for the Waterfront, and possibly other adjacent areas of Vallejo.

As the Vallejo Waterfront Master Plan is implemented and maintained in the future, there may be a variety of entities that will be responsible for the maintenance of certain portions of the public realm. Typically, if a commercial or residential use is likely to have a business or homeowners association, the private entity may take responsibility for maintenance of the landscape, hardscape, and other non-utility elements of the public right-of-way, from the curb to the edge of the right-of-way and any public access easement that is outside of the right-of-way. Consistent use of the Design Guidelines in both construction and maintenance of development will ensure that there is a consistent character to the public realm of the Waterfront regardless of who constructs or maintains it. This will support both a higher level of flexibility in financial responsibilities as well as supporting the creation of a world-class Waterfront.



Figure 1.B.1: Waterfront Framework Diagram

## B. Framework of the Waterfront Guidelines

The Waterfront Master Plan defines an overarching framework of elements that unify its character and identity as a major element of Vallejo’s community structure. The framework also links the Waterfront with the Downtown and other Districts and neighborhoods that surround it. The framework is based on the prominent features that are present in all the Districts of the Waterfront, such as the Waterfront Promenade and Mare Island Way (See Figure 1.B.1).

The Design Guidelines utilize the elements of the framework to define the overall character of the Waterfront as a unique place with design elements (e.g., lighting, benches, landscape features, etc.), that define a unified image for the entire Waterfront. At the same time, the Design Guidelines include variations in the design of some elements of the framework to respond to the unique character of the Waterfront’s three Districts.

### 1. Unifying Elements

The Waterfront Master Plan defines a set of larger elements that result in a unifying character for the Vallejo Waterfront, including:

- Waterfront Promenade, Parks, and Open Space:** The relationship of the Waterfront to Mare Island Strait is a key element in defining the character of the Waterfront; The public open space along the water’s edge reinforce the importance of the Waterfront; The Promenade will allow public access along the entire edge; The parks and open space provide opportunities for recreation, special events, and open up broader views from the Waterfront and surrounding areas to the Strait and Mare Island beyond.
- Major Streets:** The major streets of the Waterfront area link it with the rest of Vallejo, and help to link together the three Waterfront Districts. These streets include: Curtola Parkway, Mare Island Way, the Mare Island Causeway, Sonoma Boulevard, and at a smaller-scale, the Georgia Street and Marin Street extensions.
- Gateways:** There are a number of special places within the Waterfront that serve to unify the Waterfront with a strong identity while also serving to link the Waterfront to the Downtown, and other Districts and neighborhoods that surround it. These are the Waterfront’s primary and secondary gateways.



Figure 1.B.2: Existing and Proposed Roads Addressed in the Guidelines

## 2. Linkages and Transitions with the Surrounding City

The Design Guidelines also address how the public and private realms of the Waterfront link and relate with other surrounding areas of the City of Vallejo. Given the scale and relationship of these linkages and transitions, they are typically addressed in the District portions of the Design Guidelines.

- Circulation Linkages:** The major streets provide linkages from the Waterfront to the greater City of Vallejo, beyond the more immediate Waterfront area. Another set of streets and accessways provide similar linkages at a more local level between the Waterfront, the Downtown, and surrounding neighborhoods (See Figure 1.B.2). These streets include: Solano Avenue, Maine Street, Santa Clara Street, Capitol Street extension, Civic Center Drive, and Harbor Way, as well as other neighborhood streets that intersect with Mare Island Way between the Northern and Central Waterfront Districts.<sup>1</sup>
- Land Use and Urban Design Linkages and Transitions:** The relationship of the Waterfront Planning Area to the surrounding city is also defined by the linkages related to land use and urban form. The Design Guidelines address the scale and use of portions of the Waterfront that are across the street from areas of the Downtown and adjacent neighborhoods. In some cases similar uses and scales of buildings are desired; in others, landscaped buffers are more appropriate. The urban design and character of streets within the Waterfront will also need to reflect the adjacent context, as will the design character of the Waterfront Promenade, parks and open space.

## 3. The Districts of the Vallejo Waterfront

The Vallejo Waterfront Master Plan contains three distinct Districts that are linked by the major spine defined by the Waterfront parks and open spaces, and Mare Island Way (See Figure 1.B.3). The Design Guidelines balance the need to unify the Waterfront Planning Area as an identifiable element of the city with the need to reflect the specific character of each of the Waterfront Districts.

- The **Northern Waterfront** is located just south of the Mare Island Causeway between Mare Island Way and Mare Island Strait. This District has both a residential and maritime character, as well as important functions such as the existing and popular Promenade along the marinas and the activities



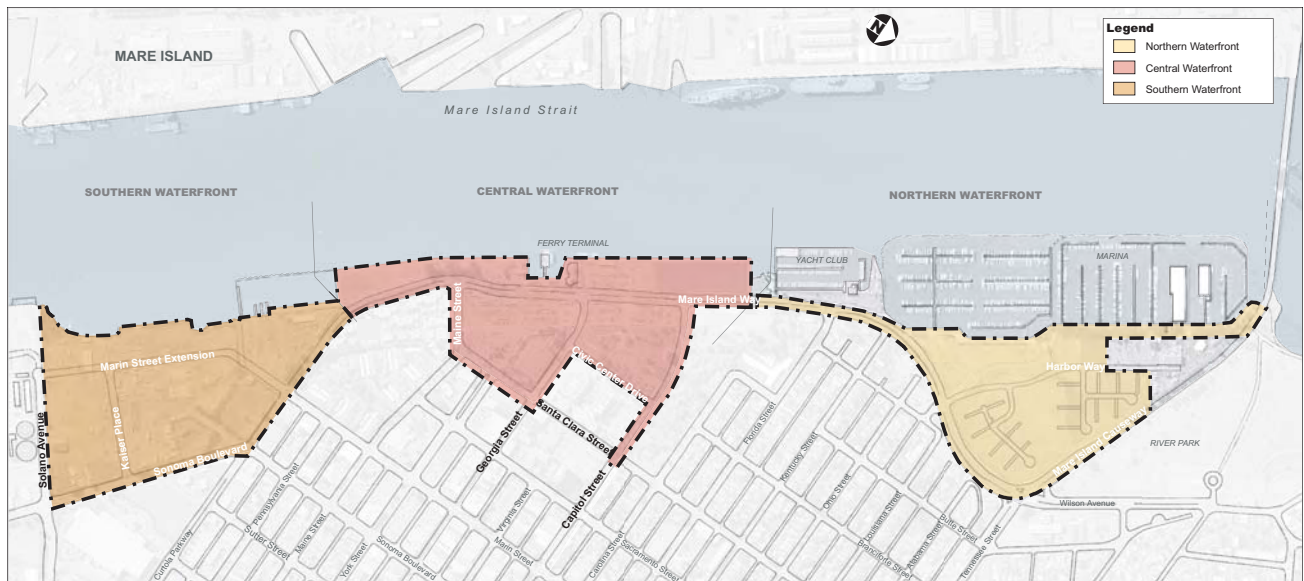

Figure 1.B.3: Vallejo's Three Waterfront Districts

that currently occur in the Waterfront Park. The planned residential development in the area provides the potential to strengthen the linkage between the Waterfront and adjacent residential neighborhoods, as well as provide more activity and “eyes-on-the-street” to improve the sense of safety and comfort in the area. The two new parks planned will include both passive and active recreation providing a new dynamic environment that will become a local and regional destination.

- The **Central Waterfront** is located just west of, and directly adjacent to, Vallejo’s historic Downtown, straddling both Mare Island Way and Georgia Street. The Central Waterfront also includes Vallejo’s two major transit connections – the Vallejo Ferry Terminal and the planned Bus Transfer Station located on York Street between Sacramento and Santa Clara Streets. Because of this adjacency to Downtown and the transit hubs, this District will be the most urban of the three Waterfront Districts, with a greater mix of uses. It will also see the greatest amount of pedestrian activity, much like the proposed revitalized Downtown. The Central Waterfront can be thought of as “bringing Downtown to the Waterfront.” The Central Waterfront also includes important civic open spaces – Dr. Martin Luther King, Jr. Unity Plaza, Festival Green, and the Service Club Field – that help link City Hall and other civic buildings in the Downtown with each other to the Waterfront.
- The **Southern Waterfront** is characterized by maritime, residential, and employment uses. Much like the Northern Waterfront, it will not be as active as the central portion of the Waterfront Planning Area. The new facilities for the Downtown post office are proposed to be located within this area. The extension of Marin Street into this area and the major new Waterfront Park to the west create an important opportunity for the new residential neighborhood to link with Downtown and the Waterfront. The homes fronting onto the park will take advantage of this recreational and visual amenity while also framing the open space and adding to the liveliness and security of the park.

The Design Guidelines are focused on the creation of a high-quality public realm in Vallejo’s Waterfront that is complemented and strengthened by high-quality development of the private realm.

**(Endnotes)**

<sup>1</sup> See Section 5.1 Circulation, of the PDMP, regarding required study of the need for connection of Civic Center Drive to Georgia Street.

## II. Unifying Elements and Linkages

### A. Waterfront Promenade, Parks, and Open Spaces

#### 1. Vision

The Waterfront's Promenade, parks and open spaces act as a center for activity for Vallejo and a linkage between Mare Island Strait and the City. The Guidelines reinforce this characteristic by defining places where a variety of activities, from passive and active recreation to community events, can take place within proximity to the Mare Island Strait, and in a way that strengthens the linkages between Downtown and the Waterfront Districts with the Strait. The vision for the open spaces of the Waterfront planning area as defined in these Guidelines are consistent with the vision of the *Vallejo Waterfront/Downtown Master Plan for Public Spaces* and make the vision consistent with the refinements of the *Waterfront's Planned Development Master Plan (PDMP)* that have occurred since the preparation of the *Master Plan for Public Spaces*. The Design Guidelines defines places for:

- Passive recreation, such as sitting, people-watching, viewing the scenery, strolling, waiting for the ferry or picnicking;
- Active recreation, such as kite flying, a variety of ball games, fishing, running, dog-walking, bicycling or boating;
- Group gatherings, such as listening to live music, informal meetings with friends, visiting the farmer's market, art festivals, boat festivals, and other city and community-sponsored events; and,
- places for living, working, shopping, and dining in the Waterfront Districts.

The Waterfront should also be a memorable place with its own distinct identity. It is an opportunity for the City of Vallejo to showcase its history as a ship building port and its participation in other wartime activities, shipping, and commerce. The design for the Waterfront parks and open spaces incorporates historic monuments and may include interpretive signage such that people can walk a path describing the Waterfront's history. Furnishings, lighting standards, landscaping, and architectural design will all create a strong identity for the Waterfront.

Its relationship to the Downtown and the rest of Vallejo will be strengthened to facilitate movement and interaction between these areas and to create a central focus for the City. This includes strengthening the visual and physical connection at key intersections through gateway elements, and also with buildings and land uses, particularly along Georgia Street and Marin Street as they link the Central and the Southern Waterfront Districts with the Downtown.

It is the goal of the *Waterfront Promenade, Parks, and Open Space* section of the Guidelines to tie together the relationship of the Waterfront to the surrounding areas, and to provide more specific guidance for how proposed development and new open spaces as well as future improvements of the public realm can mutually enhance one another. In addition, the *Street Trees, Lighting, and Furnishings* section of this chapter describes how these key elements, if incorporated consistently, can contribute to a unified appearance of Vallejo's Waterfront. Additional Guidelines regarding the specifics of the Promenade and open space elements within the Waterfront's various Districts are covered in the District-specific sections of the Guidelines, in Chapter III.

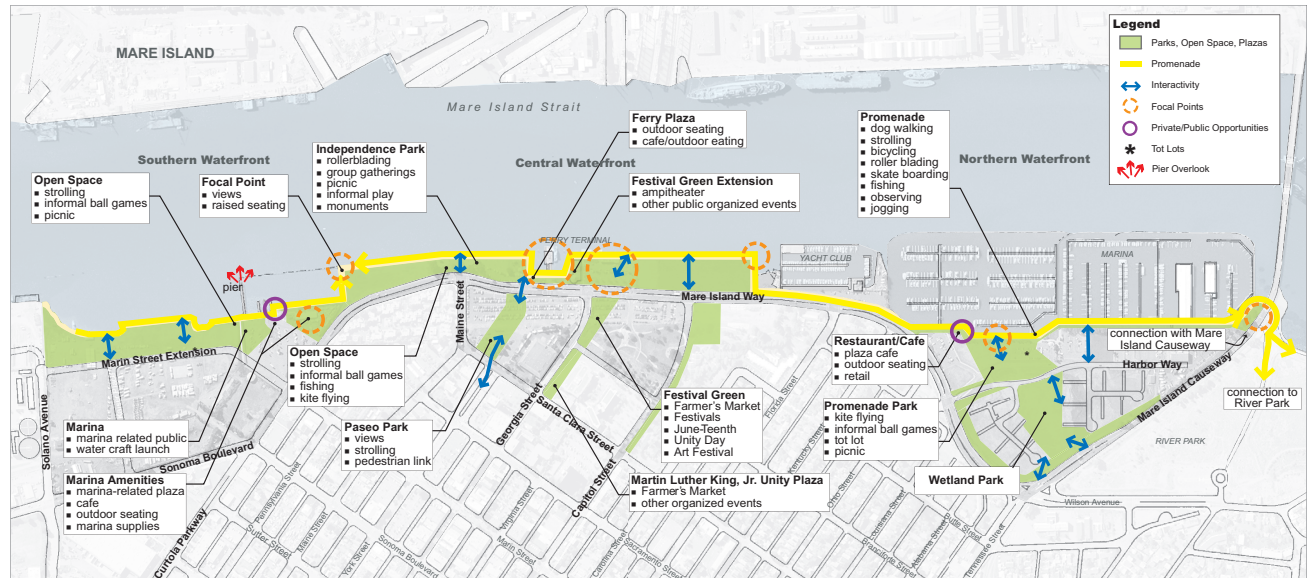

Figure 2.A.1: Waterfront Parks and Open Space Framework

## 2. General Parks and Open Space Guidelines

As new development occurs throughout the Waterfront Districts over time, new parks and open spaces will be built in all three Districts, and improvements made to existing parks and open spaces, including the Promenade. At the time of the writing of these Guidelines the City of Vallejo is convening citizens for a series of public hearings to solicit the public’s input about their needs and expectations with respect to future open spaces and amenities in the Waterfront. **While these Guidelines address a variety of key open spaces in all three Districts, these should be understood as a contribution to the ongoing discussion and dialogue with the public.** This is reflected in the way the Guidelines and underlying concepts are presented:

- Only key locations were selected, particularly those that have the most direct relationship to private development in the Waterfront Districts, and
- This document provides Guidelines not standards, and thereby it provides only guidance and input into the planned public process.

As mentioned in the Introduction Chapter, these Design Guidelines build from existing policies of the City. The *Vallejo Waterfront/Downtown Master Plan for Public Spaces* is of particular importance to the design and character of the Waterfront’s parks and open spaces, and these Guidelines recognize and build from the intent of that Master Plan.

As all three Districts have rather distinct parks and open spaces these are discussed in greater detail in each District’s Design Guidelines section.

## 3. Waterfront Promenade

Particular design elements span the entire Waterfront from one end, at the Mare Island Causeway where it meets Tennessee Street, to the other end at Solano Avenue, unifying it as a distinct place. These elements include light fixtures, furnishings, and landscaping. This section provides Guidelines for the design elements that are utilized throughout the Promenade. District specific Guidelines are included in the District sections.

Views from the Waterfront and the Promenade can be dramatic and inspiring. This aspect of the Waterfront should be taken advantage of to the fullest extent. Currently, the Promenade provides few accommodations for seating where people may rest, watch activity within the Waterfront and along the Strait, fish, and gather with friends.

The paved Promenade that passes along the majority of the Waterfront's edge is a major attraction to the Waterfront and is used by visitors and local residents on a regular basis. However, the existing condition of the Promenade is relatively spartan and does not provide much opportunity for people to comfortably stop and enjoy the views to the Mare Island Strait and Mare Island, as well as back towards Downtown Vallejo, the existing neighborhoods, or the future new development of the three Waterfront Districts (See Figure 2.A.2). Opportunities exist to make a range of improvements that can take advantage of the unique setting of the existing Promenade. Figures 2.A.3 and 2.A.4. illustrate the following potential improvements that could be implemented in areas where the Promenade exists today:

- **Seating:** Seat walls could be built within the center of the Promenade allowing people to stop, talk to friends, and enjoy views in a variety of directions towards the Strait or inland.
- **Lighting:** The existing lighting that exists along the Promenade could be removed as it forms a visual barrier between the park and the Promenade and the fixtures' location within the decomposed granite edge of the greens is an impediment to use of the edge as a jogging path. New lighting could be located in line with the new seat walls working with them to break down the scale of the 30 foot wide concrete surface of the Promenade.

Additional specific design guidance for overlooks and other District specific elements are provided in *Section III C.2.1.1 Promenade Overlooks.*



Figure 2.A.2: The existing Promenade provides dramatic views but few amenities for users.

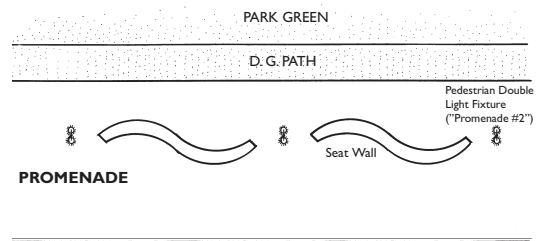

Figure 2.A.3: Plan of Promenade Improvements

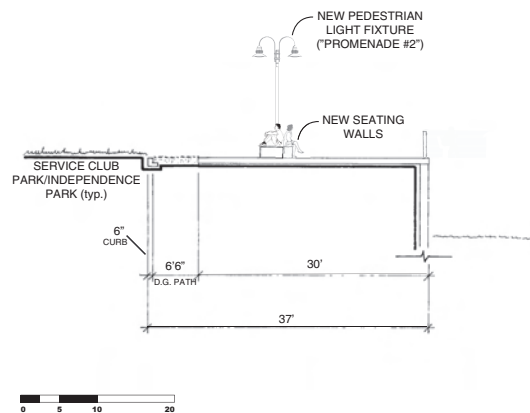

Figure 2.A.4: Section of Promenade Improvements





Figure 2.A.5 and Figure 2.A.6: Existing public “furniture” within the Waterfront does not create a unified identity.

#### 4. Construction and Maintenance of Improvements

The goal and intent of the Design Guidelines is to provide explicit direction for producing a high quality built and open space environment throughout the Waterfront. To this end, the Design Guidelines encourage the City of Vallejo to establish, and all developers/builders to participate in, a Landscape Lighting and Maintenance District (LLMD). The open space and its amenities will be installed through the investment of public and private funds, but their long-term maintenance can only be ensured if the proper funding mechanisms are established early in the development of these improvements. Properly funded and maintained public realm improvements along the Waterfront Districts will result in a quality and highly desirable recreational experience for residents and visitors for years to come.



Figure 2.A.7: Existing Street Furniture in Downtown.

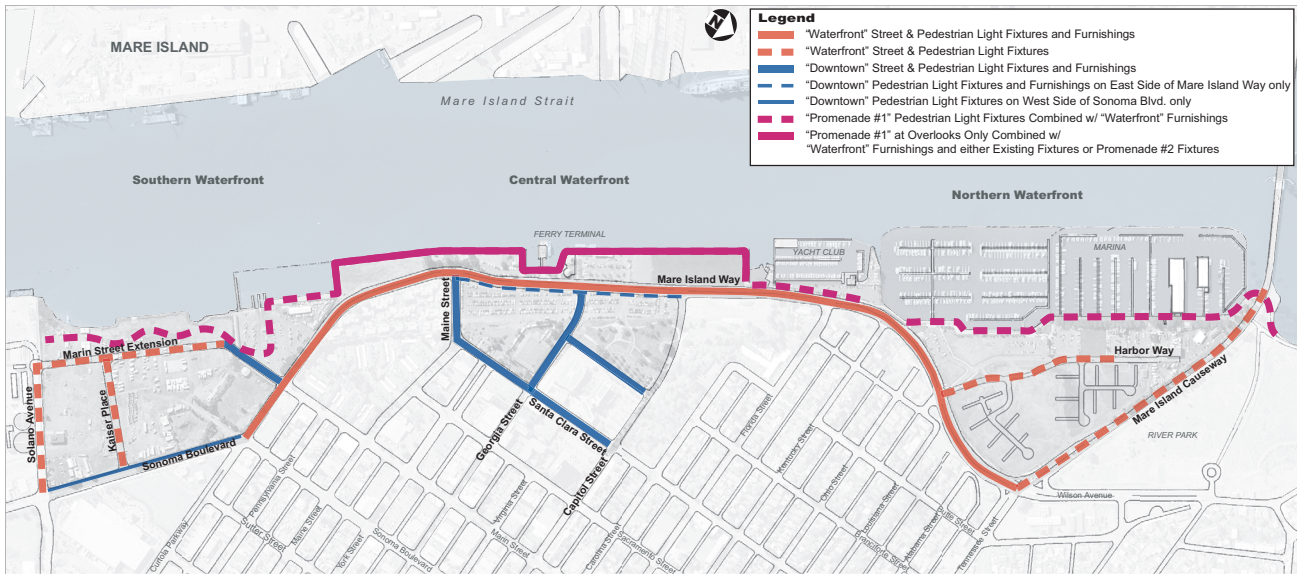

Figure 2.B.1: Street Furnishing and Light Fixture Concept Diagram

## B. Street Trees, Lighting, and Furnishings

Street lights, benches, bicycle racks, trash/recycling receptacles, bollards, and newspaper racks are all elements in the “family” of street furniture that can create a comfortable environment for the public within the Waterfront, and that provide the desired identity of a given area. These are a key factor in defining a strong identity for the Waterfront within the City of Vallejo. These elements also serve to define the different character of the three Waterfront Districts.

### 1. Streetscape Elements

Figure 2.B.1 provides an overview of how light fixtures and street furnishings are to be used to create distinguishable streetscapes in the Waterfront. The basic concepts are to:

1. Define Mare Island Way as the key linkage between all three Waterfront Districts. It is proposed to expand the use of the recently introduced “Waterfront” fixture along the street.
2. Expand use of the Waterfront fixture to include streets within the Northern and Southern Waterfront to visually unify the streets and open spaces of the Waterfront.
3. Define a set of other fixtures for use in the Waterfront that complement the existing street elements.
4. Expand the use of the “Downtown” furnishings defined in the Downtown Vallejo Specific Plan and Design Guidelines; this includes the use of the Downtown benches and trash/recycling receptacles painted the color of the existing Waterfront fixtures to reinforce the linkage between the Downtown and the Waterfront.
5. Use the Downtown fixture on the east side of Mare Island Way in the Central Waterfront District to provide a visual clue to passersby on the street that they have arrived at the center of the Waterfront where it is connected to the Downtown.



Figure 2.B.2: “Waterfront” Roadway Lighting Fixture

## 1.1 Light Fixtures

One of the most important and effective elements of the streetscape in creating a theme for the Waterfront are the lighting fixtures used along its streets and in its open spaces. This includes both lighting for the streets, and pedestrian-scaled lighting for sidewalks and the Waterfront Promenade.

While the final spacing and lighting design will be determined prior to construction, the following Guidelines should be observed during the design development phase of future street improvements:

1. The spacing of light fixtures and that of street trees should be coordinated to the greatest extent possible. This will help to reduce conflicts between tree crowns and light distribution from the fixture heads. Well coordinated spacing of light fixtures and trees also establishes a rhythm along the street that enhances the pedestrian experience.
2. Along Mare Island Way, where the simultaneous use of both the Waterfront and the Downtown fixtures is proposed, these should generally not be placed side-by-side. Rather, a rhythmic spacing of these fixtures should be devised that avoids this condition, and conserves the sidewalk width for pedestrians.

### “Waterfront” Standard

The recently introduced light fixture on Mare Island Way (north of Florida Street) begins to create a character for Mare Island Way and the Waterfront in this area (See Figure 2.B.2). Over time as Mare Island Way and other streets in the Waterfront Districts are improved, this fixture should be used. In areas where the Waterfront fixtures have already been installed, two additional measures should be taken to provide fixtures and lighting levels specifically tailored to pedestrian needs:

1. Addition of a second fixture head to already existing Waterfront fixtures (See Figure 2.B.3).
2. One additional fixture on a 12-foot pole between each of two fixtures scaled for roadway lighting in order to provide high quality lighting for pedestrians.

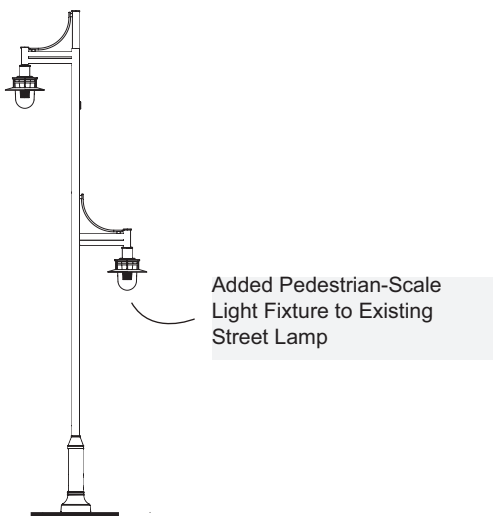

Figure 2.B.3: Pedestrian-Scale Lighting Fixture Added to Existing Lamp

Pedestrian-scaled fixture heads should be installed to face toward the sidewalk (Please refer to the individual street cross-sections provided in the individual Waterfront District sections for additional guidance).

Where this light fixture is newly introduced along a street it should be provided to light both the pedestrian portion of the street and the street within the curbs. Generally, the combined roadway and pedestrian fixtures should be spaced approximately at 80 feet on-center, and the pedestrian-scale fixtures should be spaced approximately 40 feet on-center.

**Manufacturer:** Lumec, Inc.

**Model:** Candela-2-RR (pedestrian-scale pole base fixture); Candela-1-RR-CN (roadway fixture).

**Pole Height:** match existing height for typical roadway fixture and 12 feet for pedestrian fixtures.

**Material:** 4" round aluminum pole with base cover (roadway and pedestrian-scale fixtures).

**Type of Finish:** per manufacturer's specification unless within proximity of Mare Island Strait where finish should be – prime then finish paint to meet AAMA 605.2 standards for salt spray resistance.

**Color:** to match existing fixtures of this type along Mare Island Way.

### **"Promenade" Fixtures**

Two fixtures are recommended for use in relation to the Promenade to complement the Waterfront street fixtures while distinguishing the Promenade as a key design element in the Waterfront.

#### **1.1.0.A Fixture #1**

This fixture has been selected to complement the existing fixtures along the Promenade for use in new improvements, such as the potential overlooks described in the Central Waterfront Guidelines. See *Section III.C.2.1.1 Promenade Overlooks*.

**Manufacturer:** Lumec, Inc.

**Model:** CANDS2-SR (upright fixture); APR4/LBC2 (pole and base cover).

**Pole Height:** 12 feet.

**Material:** 4" round aluminum pole with base cover.

**Type of Finish:** Prime then finish paint to meet AAMA 605.2 standards for salt spray resistance.

**Color:** to match existing "Waterfront" lighting fixtures along Mare Island Way.

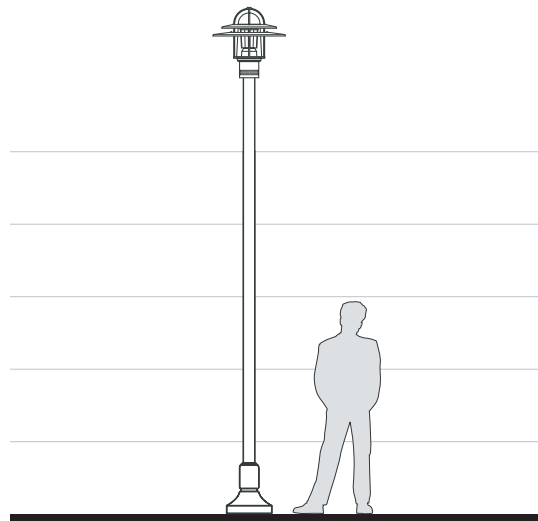

Figure 2.B.4: Promenade Fixture #1



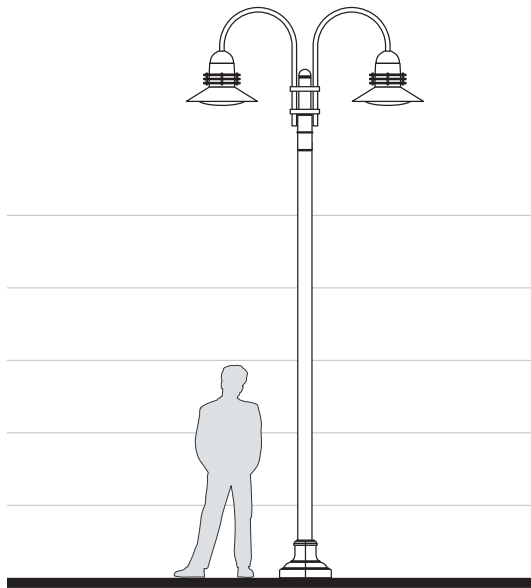

Figure 2.B.5: Promenade Fixture #2

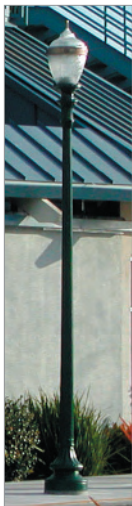

Figure 2.B.6: “Downtown” Standard Lighting Fixture

### 1.1.0.B Fixture #2

This fixture would be used if the decision is made to replace the existing fixtures along the Promenade (See the detailed discussion in the Central Waterfront Guidelines). If the existing fixtures are not replaced, they should be painted to match the “Waterfront” lighting fixtures.

**Manufacturer:** Lumec, Inc.

**Model:** CANDS2-SR (upright fixture); APR4/LBC2 (pole and base cover).

**Pole Height:** 12 feet.

**Material:** 4” round aluminum pole with base cover.

**Type of Finish:** Prime then finish paint to meet AAMA 605.2 standards for salt spray resistance.

**Color:** to match existing “Waterfront” lighting fixtures along Mare Island Way.

### “Downtown” Standard

Along some of the streets in the Central Waterfront District (See Figure 2.B.1) the lighting fixture that is used throughout most of the Downtown will be used to reinforce the relationship between the Downtown and the Waterfront (Figure 2.B.6).

**Manufacturer:** Spring City.

**Model:** Washington – 199 Globe w/Brass Band (single head only).

**Pole Height:** 12 feet (maximum).

**Material:** Heavy wall cast aluminum.

**Type of Finish:** per manufacturer’s specification.

**Color:** Medium Gloss Black (per Downtown Specific Plan specification).

## 1.2 Street Furnishings

A variety of street furnishings should be provided along the Waterfront’s streets and in its parks and open spaces that draw from the furnishings used in the Downtown and that also achieve a balanced relationship with the more modern design of the existing Waterfront lighting fixture.

## Benches

Benches provide an important opportunity for people to occupy and spend time in the public realm of the Waterfront. Benches will be located along the Promenade and Waterfront Parks, the Ferry Terminal Plaza and other public open spaces. They can also be located on bulb-outs and other places along the street. Consideration should be given to locating benches in safe and visible locations with an orientation to allow people to enjoy views and talk with friends or people they meet along the Waterfront. The benches should be the same as those used and specified in the *Downtown Specific Plan* (Figure 2.B.7).



Figure 2.B.7: Downtown and Waterfront Bench

**Manufacturer:** Landscapeforms.

**Model:** Presidio Collection (include arms when necessary to discourage loitering).

**Material:** Metal.

**Type of Finish:** per manufacturer’s specification (Pangard II® polyester powdercoat) unless within proximity of Mare Island Strait where finish should be – prime then finish paint to meet AAMA 605.2 standards for salt spray resistance.

**Color:** to match existing “Waterfront” lighting fixtures along Mare Island Way when fixture is located in the Southern or Northern Waterfront District, or on the west side of Mare Island Way in the Central Waterfront; on the east side of Mare Island Way color should be Forest Green (per *Downtown Specific Plan* specification).

## Tree Grates

Healthy trees require exposure of the soil around them to air. An open planter bed of at least 6 by 6 feet is typically desired to support healthy and fast growth of trees. In areas of higher pedestrian activity open planters reduce the usable area of the sidewalk. Therefore, the Guidelines recommend the use of tree grates on several of the streets within the Waterfront.

**Manufacturer & Model:** The specific manufacturer and model should be coordinated with the selection for the Downtown planning area as the current Design Guidelines for Downtown Vallejo do not identify a specific manufacturer or model.

**Material:** Cast iron ADA approved grate.

**Dimensions:** 6 foot by 8 foot is desired minimum,



Figure 2.B.8: Typical “Hoop” Bicycle Rack

but a range of 5 to 8 feet wide and long is acceptable depending upon tree species and location.

### Bicycle Racks

The provision of bicycle racks throughout the Waterfront in proximity to the places that are an attraction to bicyclists such as the ferry terminal, recreational and event areas, streets with retail shopping, etc., will be important for creating an environment that supports transportation alternatives to the automobile (Figure 2.B.8).

**Manufacturer:** DeroRacks, Inc.

**Model:** Hoop rack for storage of 2 bicycles maximum per loop; in ground mounting is recommended.

**Material:** 1.5 inch Schedule 40 pipe (1.9 inch OD).

**Type of Finish:** per manufacturer’s specification unless within proximity of Mare Island Strait where finish should be – prime then finish paint to meet AAMA 605.2 standards for salt spray resistance.

**Color:** to match existing “Waterfront” lighting fixtures along Mare Island Way when fixture is located in the Southern or Northern Waterfront District, or on the west side of Mare Island Way in the Central Waterfront; on the east side of Mare Island Way color should be Forest Green (per Downtown Specific Plan specification).

### Trash/Recycling Receptacles

Trash/recycling receptacles should be located throughout the Waterfront in locations where people congregate and in locations where transit riders arrive or leave the area. Consideration to access by sanitary workers should be given when deciding where to locate trash/recycling receptacles (Figure 2.B.9).



Figure 2.B.9: Downtown and Waterfront Trash/Recycling Receptacle

**Manufacturer:** Landscapeforms

**Model:** Presidio Collection

**Material:** Metal

**Type of Finish:** per manufacturer’s specification (Pangard II® polyester powdercoat) unless within proximity of Mare Island Strait where finish should be – prime then finish paint to meet AAMA 605.2 standards for salt spray resistance



**Color:** to match existing “Waterfront” lighting fixtures along Mare Island Way when fixture is located in the Southern or Northern Waterfront District, or on the west side of Mare Island Way in the Central Waterfront; on the east side of Mare Island Way color should be Forest Green (per Downtown Specific Plan specification).

### Bollards

Bollards may be needed in locations where pedestrian or bicycle access improvements, or plazas, create opportunities where motor vehicles could enter into spaces where they are not allowed. Bollards can also be used as design elements to define an edge or transition between public spaces. Bollards may be used in the Waterfront and in other locations within the project area, one of which is the intersection of Civic Center Drive and Georgia Street where removable bollards could be used.<sup>1</sup> The recommended bollard has been selected to complement the style of the other furnishings, particularly the Waterfront lighting fixtures (Figure 2.B.10).

**Manufacturer:** FairWeather Site Furnishings.

**Model:** B-3.

**Height:** to match height of existing bollards on the Waterfront.

**Material:** cast aluminum.

**Type of Finish:** per manufacturer’s specification unless within proximity of Mare Island Strait where finish should be – prime then finish paint to meet AAMA 605.2 standards for salt spray resistance.

**Color:** to match existing “Waterfront” lighting fixtures along Mare Island Way when fixture is located in the Southern or Northern Waterfront District, or on the west side of Mare Island Way in the Central Waterfront; on the east side of Mare Island Way color should be Medium Gloss Black (per Downtown Specific Plan specification).

### Newspaper Racks

Newspaper racks are a necessary part of the public realm, and should be encouraged in proximity to transit facilities where transit riders appreciate the opportunity to find something to read while they ride transit. When uncontrolled, newspaper racks can be an eyesore and a

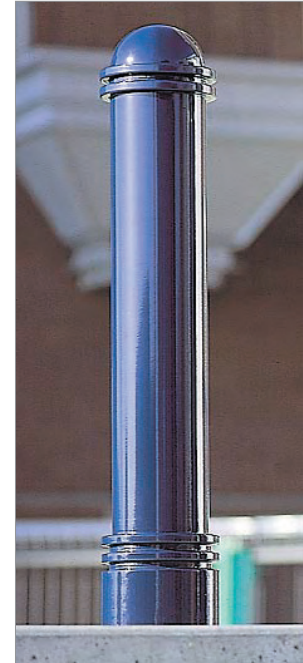

Figure 2.B.10: Waterfront Bollard



Figure 2.B.11: Newspaper Rack Example

barrier to pedestrian circulation. The use of well designed modular racks that can be grouped together is strongly encouraged. The racks should be designed to resist vandalism and rust (Figure 2.B.11).

**Manufacturer:** No particular manufacturer or model has been selected

**Material:** metal.

**Type of Finish:** per manufacturer’s specification unless within proximity of Mare Island Strait where finish should be – prime then finish paint to meet AAMA 605.2 standards for salt spray resistance.

**Color:** to match existing “Waterfront” lighting fixtures along Mare Island Way when fixture is located in the Southern or Northern Waterfront District, or on the west side of Mare Island Way in the Central Waterfront; on the east side of Mare Island Way color should be Medium Gloss Black (per Downtown Specific Plan specification).

## 2. Trees for Waterfront Streets

Street trees are typically the dominant element used to create comfortable and memorable streets, and can do much to create an identity for a sub-area of a city. Currently much of the Vallejo Waterfront is lacking in trees, and while this maximizes openness to views towards the Mare Island Strait, it also, in some locations, results in a desolate environment. These Design Guidelines balance the desire to maintain the unique views offered in and throughout the Waterfront area, while also providing opportunities for trees that create an identity and level of pedestrian comfort for people who use and view the Waterfront.



Figure 2.B.12: Diagram of Street Tree Selection within the Waterfront

This section of the Guidelines describes the street tree selections for the major streets within the Waterfront. The overarching design concepts are –

- To create a relationship to the street trees that have been identified in the Downtown Specific Plan in order to reinforce the linkages between the Downtown and the Waterfront, and
- To create a strong identity for those locations where the Waterfront’s open spaces are bounded and framed by adjacent streets.

Table 2.B.1: Street Tree Recommendations

Street Segment	Selected Street Tree	Design Concept/Criteria
<p>Mare Island Way from Intersection with Tennessee Street to Intersection with Marin Street, and Marin Street Extension from roundabout or 3-way stop to Solano Avenue (Option 1)</p>	 <p>Canary Island Palm (Phoenix Canariensis)</p>	<ul style="list-style-type: none"> <li>▪ Create a strong image</li> <li>▪ Grow well in high wind &amp; salt air conditions</li> <li>▪ Maintain open views</li> <li>▪ Does not provide as much shade as Frontier Elm</li> </ul>
<p>Mare Island Way from Intersection with Tennessee Street to Intersection with Marin Street, and Marin Street Extension from roundabout or 3-way stop to Solano Avenue (Option 2)</p>	 <p>Frontier Elm (Ulmus 'Frontier')</p>	<ul style="list-style-type: none"> <li>▪ Create a strong image</li> <li>▪ Grow well in high wind</li> <li>▪ Provides shade</li> <li>▪ Does not provide as open a view compared to Canary Island Palm</li> </ul>
<p>Capitol Street, Maine Street, Kaiser Place, and Solano Avenue (from Sonoma Boulevard to Marin Street Extension)</p>	 <p>Red Maple (Acer Rubrum)</p>	<ul style="list-style-type: none"> <li>▪ For Capitol Street is consistent with remainder of street in the Downtown Specific Plan Area</li> <li>▪ For Kaiser Place and Solano provides a shaded street with form similar to London Plane Trees on Sonoma Boulevard with a different fall color</li> </ul>





<p>Sonoma Boulevard, Marin Extension (from Mare Island Way to roundabout or 3-way stop at entry to boat launch parking lot</p>	 <p>London Plane Tree (Platanus Acerifolia 'Yarwood')</p>	<ul style="list-style-type: none"> <li>Consistent with portions of these streets in the Downtown Specific Plan</li> <li>"classic" broad tree for major streets</li> </ul>
<p>London Plane Tree (Platanus acerifolia 'Yarwood') Georgia Street, Santa Clara Street, and Civic Center Drive</p>	 <p>Evergreen Elm (Ulmus Parviflora)</p>	<ul style="list-style-type: none"> <li>Georgia Street: has existing plantings of Evergreen Elms on south side of street</li> <li>Santa Clara Street: consistent with Downtown Specific Plan</li> </ul>
<p>Mare Island Causeway from Mare Island Way to foot of Causeway on south side of the street</p>	 <p>California Pepper Tree (Schinus Molle)</p>	<ul style="list-style-type: none"> <li>Existing tree along this street</li> </ul>
<p>Harbor Way</p>	 <p>Ornamental Pear (Pyrus Calleryana 'Aristocrat')</p>	<ul style="list-style-type: none"> <li>Provides shade for pedestrians</li> <li>Stays smaller and narrower to maintain high-quality views</li> </ul>





Figure 2.C.1: Diagram of Existing and Proposed Streets Addressed in these Guidelines

## C. Major Streets

There are several key streets within the Waterfront that serve to link the three Districts as well as to link the Waterfront with the broader reaches of Vallejo, the Downtown, and Mare Island. The following Guidelines describe the envisioned design of these key streets, including Mare Island Way, the Georgia Street extension, and the Marin Street extension.

### 1. Mare Island Way

The design of Mare Island Way is critical to creating a vibrant and dynamic interaction between the Ferry Terminal, the Waterfront parks and Promenade, and the areas to the east of Mare Island Way, including the Downtown, existing neighborhoods, and portions of the Waterfront Districts. Since Mare Island Way is a major arterial street that will carry relatively high volumes of auto and bus traffic, it requires careful design in order to balance these modes with bicycle and pedestrian access. It is particularly important to avoid an environment that is dominated by motorized traffic and that then creates a barrier to pedestrian movement between uses on either side of the street. In order to achieve a strong connection across Mare Island Way, it is essential to provide safe and convenient crossings for pedestrians. Overall, the design needs to consider the pedestrian as equally important, if not primary, to all other modes of travel. Pedestrians should feel safe and comfortable walking to and along both sides of Mare Island Way, as well as across it. Giving priority to pedestrians in the Central Waterfront is of particular importance given the high level of pedestrian activity generated by the Ferry Terminal. This activity will only increase in the future with expanding ferry service, other additional transit, and new development in Vallejo Station and Downtown Vallejo.

Mare Island Way represents the “spine” of the three Waterfront Districts, similar to Georgia Street’s function as the “spine” of Vallejo’s Downtown. The perception of the street as a connecting element and as the primary access route is reflected in, and reinforced by, the street’s physical and design characteristics along its entire length, and implementing these Design Guidelines will reinforce and improve the existing character and function of Mare Island Way. In doing so, it is important to recognize that while the street should be perceived as a whole, it is equally important that the specific conditions in the context of the street be reflected in its design and functionality. For example, the character, size, and design elements between the curb and adjacent development vary if the sidewalk is adjacent to a parking lot, a park, or a retail storefront.

Cross sections and detailed discussions on proposed improvements for Mare Island Way are provided within the individual District Guidelines sections. The Guidelines cover how the street should address specific conditions along particular segments within the three Districts. Overall, however, the street is unified through consistent treatments for lighting, trees and landscaping. The final paragraphs of this subsection summarize the key streetscape elements that lend continuity to the design of the street.

### Street Tree Options for Mare Island Way

Street trees are the major design element that can be used to create a consistent character along the length of a street that is comprehensible to those driving along the street and those bicycling or walking along the street. The challenge on a street with a context like Mare Island Way is in creating a memorable pattern of street trees while maintaining important views across the street. The earlier Vallejo Waterfront/Downtown Master Plan for Public Spaces did not propose street trees along the majority of Mare Island Way. These Guidelines provide two choices for balancing the importance of trees for character and shade along the street, and the need to maintain and enhance views towards the Mare Island Strait from the street and development to the east.

All Mare Island Way cross sections presented in these Guidelines illustrate Canary Island Palms (*Phoenix Canariensis*) as the consistent street tree for this street (Figure 2.C.3). This choice maintains views, but may not achieve the character or shade desired for Mare Island Way. However, a potential alternative is also provided that would plant a larger tree with a narrower form, such as the Frontier Elm (*Ulmus 'Frontier'*). In this pattern (Figure 2.C.4), the spacing of the trees provides a “window” for views towards the Strait.

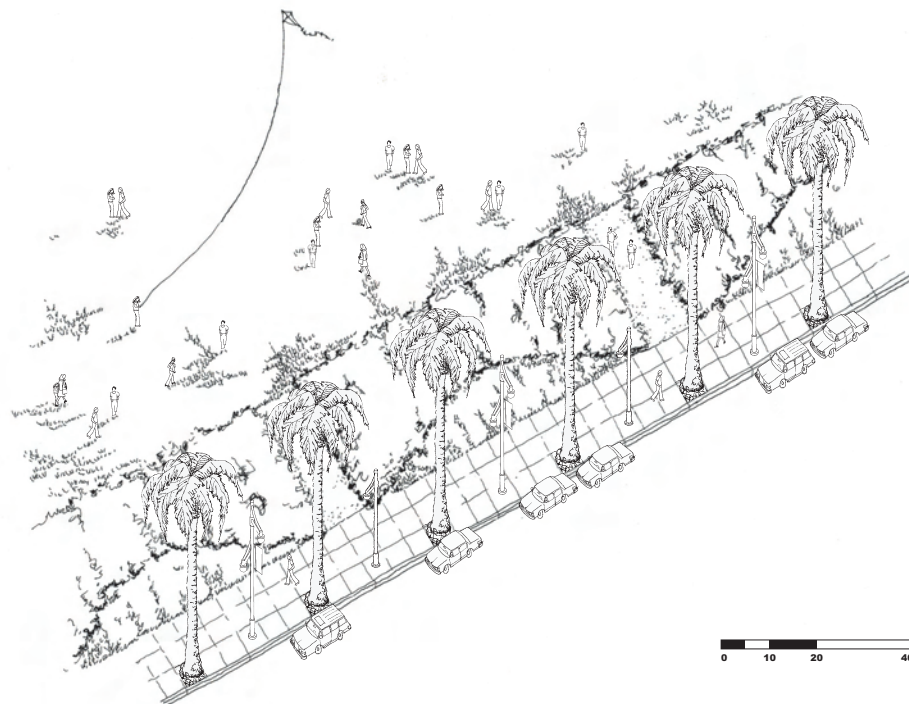

Figure 2.C.2: Concept for Mare Island Way Streetscape Along Parks and Open Spaces

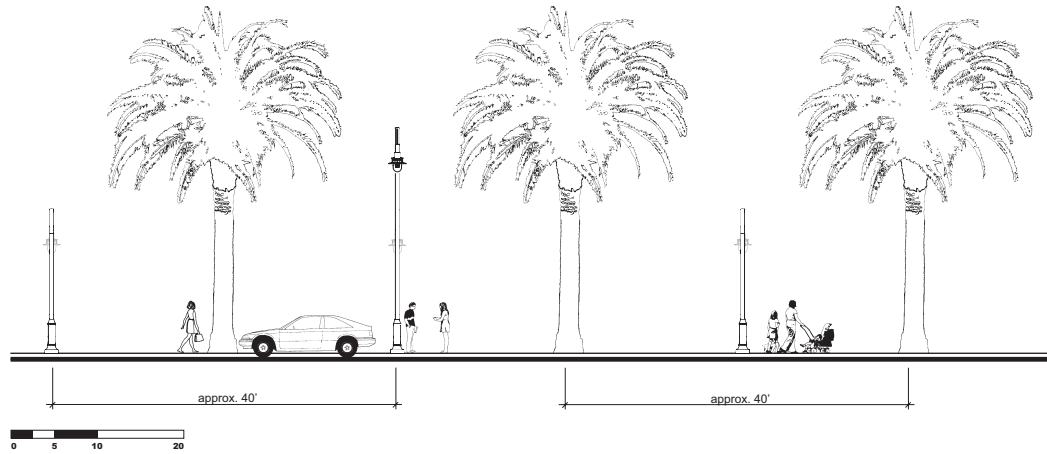

Figure 2.C.3: Pattern Option 1: Canary Palms



Figure 2.C.4: Pattern Option 2: Frontier Elms



### *Unifying Streetscape Elements for Mare Island Way*

It is critical to enhance the character of Mare Island Way as the main connector of all Waterfront Districts. In order to achieve this the various streetscape elements for Mare Island Way have been selected to create a consistent character along the street, including using the color of the existing new light fixtures along the street on new streetscape elements such as benches, trash receptacles, bollards, and pedestrian-scale light fixtures. Overall, the set of streetscape elements along Mare Island Way includes:

- Street Lights (for lighting that includes the roadway)
- Pedestrian-scale Lights
- State flags
- Tree Grates
- Trash/Recycling Receptacles
- Benches
- Bicycle Racks
- Bollards

For more details on these street furnishings, please see *Section II.B Street Trees, Lighting, and Furnishings*.

## **2. Georgia Street Extension**

Georgia Street is the civic and main street connecting Downtown Vallejo and the Waterfront. It will be associated with a variety of open space and civic, cultural and commercial amenities that will effectively bridge the Downtown to the Waterfront and the Ferry Terminal. For this reason lighting, furnishings and street trees are defined in a manner consistent to Vallejo's Downtown.

Cross sections and detailed discussions on proposed improvements for Georgia Street are provided within *Section III.C.2.2.1.A Georgia Street Extension*.

## **3. Marin Street Extension**

The proposed Marin Street Extension not only provides access to new residential, retail, and industrial/research and development uses, but also to marina facilities, such as a boat launch, future open spaces, and the Promenade extension in the Southern Waterfront District. Through the link to Solano Avenue at its southern end, uses along the Marin Street Extension can also be accessed from areas to the east of Highway 29. Cross sections and detailed discussions on proposed improvements for the Marin Street Extension are provided within *Section III.B.2.2.1.A The Marin Street Extension*.

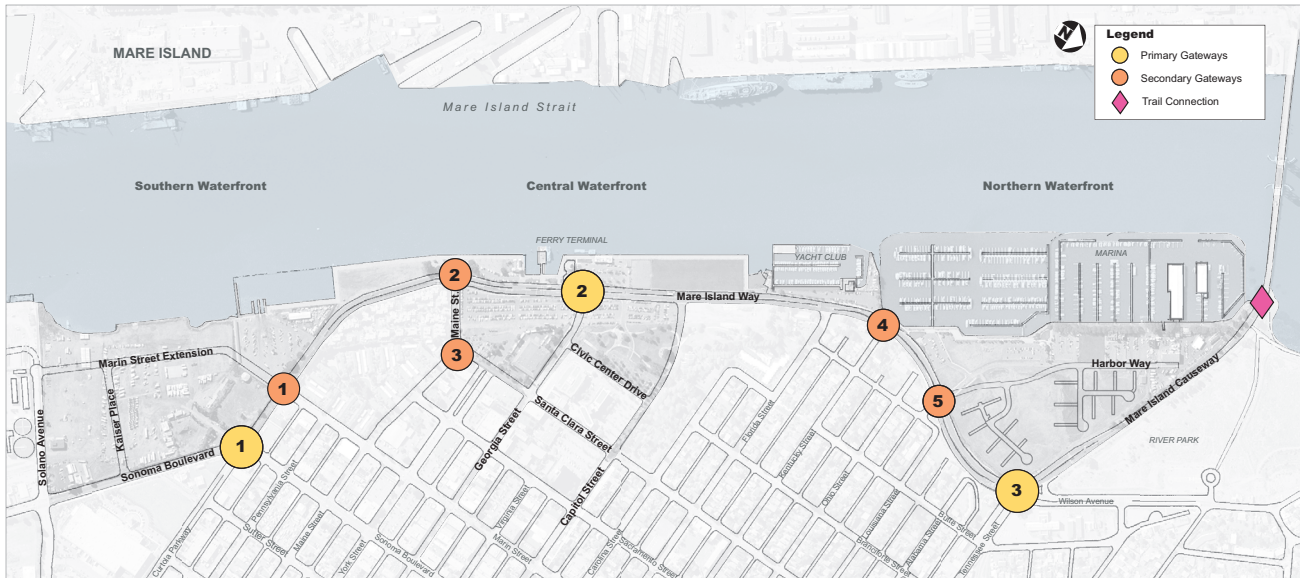

Figure 2.D.1: Diagram of Primary and Secondary Gateways

## D. Gateways

At key locations where the Waterfront Districts connect with adjacent areas, primarily at major street intersections, consideration needs to be given to the design of elements of these locations as gateways that mark entry into Vallejo's Waterfront. There are three primary gateways and six secondary gateways defined in these Design Guidelines (Figure 2.D.1).

### 1. Primary Gateways

Primary gateways are those locations where the highest volumes of people will enter into the Waterfront, whether arriving by transit, auto, bicycle, or on foot. The scale and geometry of the intersections at these locations and the desire to maintain open views towards the Waterfront preclude the use of physical arching gateway structures to mark the primary gateways. Also, the use of banners or other more temporary elements to mark the gateways is discouraged. Rather, the Design Guidelines recommend the use of landscape and streetscape elements at or adjacent to corners, and at one location a building, as landmarks for these gateways. The unified approach to the landscape and streetscape of major streets in the Waterfront will also serve to mark entry into the Waterfront planning area from other parts of the city. The primary gateways include:

1. Southern Gateway
2. Central Gateway
3. Northern Gateway

Further discussion of each District's Primary Gateways can be found in *Chapter III Waterfront District Guidelines* within each District Section.

## 2. Secondary Gateways

Secondary gateways are also important entry points into the Waterfront and connections to adjacent neighborhoods. These gateways address intersections with lower volumes of traffic, both auto and pedestrian. Design elements should also emphasize these important intersections. Use of streetscape, landscaping, or built landmarks is also the recommended approach for marking the secondary gateways in the Vallejo Waterfront. The secondary gateways include:

1. Mare Island Way and Marin Street Intersection
2. Mare Island Way and Maine Street Intersection
3. Maine Street and Santa Clara Intersection
4. Mare Island Way and Kentucky Street Intersection
5. Mare Island Way and Harbor Way Intersection

Further discussion of each District's Secondary Gateways can be found in *Chapter III Waterfront District Guidelines* within each District Section.

### (Endnotes)

<sup>1</sup> See Section 5.1 Circulation, of the PDMP, regarding required study of the need for connection of Civic Center Drive to Georgia Street.

# III. Waterfront District Guidelines

This chapter includes the majority of the Guidelines that will determine the design success of Vallejo’s Waterfront District. The first section of the Guidelines focuses on those elements that are applicable throughout the Waterfront. This is followed by sections containing Guidelines that are applicable to each of the three Districts and that define the unique character of these Districts.

As described in the Introduction chapter, there are Guidelines for both the public realm of the Waterfront and the private realm of the Waterfront. The public realm includes the public streets, parks, and open spaces of the Waterfront, as well as areas on private property that are accessible to the public, such as sidewalk access easements. Some portions of the public realm will be built and maintained by private entities, such as homeowners associations, while others will be built and/or maintained by the City. A further description of these issues is included in *Chapter II: Unifying Elements and Linkages*.

## A. Guidelines for All Districts

This section of the Guidelines discusses those issues that are applicable to all of the Waterfront Districts – within both the public and private realms.

### 1. Public Realm Guidelines

Aspects and elements of the public realm that apply to all three Waterfront Districts are addressed in *Chapter II: Unifying Elements and Linkages*. All other elements and components of the public realm that are unique to individual Districts are discussed in the respective district-specific sections of this chapter.

### 2. Private Realm Guidelines

This section provides Guidelines for the design of building orientation, frontages, massing and scale, and detailing that are common to all buildings within the Vallejo Waterfront. Guidelines for building design that are unique to each of the Waterfront Districts are located within the individual district sections.

## 2.1 Green Site and Building Design

To a great degree, development in the Vallejo Waterfront is sustainable and green; One, because it is infill development, and two, because much of it is mixed-use, creating a walkable and bikeable environment that encourages alternative transportation choices. The Central Waterfront District is particularly sustainable, because it is transit-oriented with its proximity to the Ferry Terminal and major bus transit service. In addition, the public/ferry parking creates opportunities for shared efficient use of structured parking. Parcels S and T in the Southern Waterfront District are “brownfield” re-use sites that will involve clean-up of some soils currently on the site.

That said, there are opportunities to further enhance the sustainability of development in the Vallejo Waterfront by employing the techniques and practices of green site and building design. In addition to the Guidelines below, the following resources are also useful in guiding the implementation of green building and site design techniques:

- Alameda County Waste Management Authority & Alameda County Source Reduction and Recycling Board’s, *Multifamily Green Building Guidelines*, information is available at [www.stopwaste.org](http://www.stopwaste.org).
- The US Green Building Council’s Leadership in Energy and Environmental Design (LEED) Green Building Rating System®, information is available at [www.usgbc.org/LEED](http://www.usgbc.org/LEED).
- The *Stormwater Guidelines for Green, Dense Redevelopment* for the City of Emeryville will be adopted in late summer or early fall of 2005, and will be available as a resource.

The following Guidelines are provided to support green development in the Waterfront Districts:

1. Maximize land use efficiency through a vertical mix of uses, structured parking, and efficient use of space in site and building design.
2. Improve and protect water quality through treatment, retention, and infiltration of stormwater run-off through non-mechanical means when possible using techniques such as:

- On-site water storage/harvesting to supplement irrigation;
  - Providing landscape features for bio-retention, bio-filtration, and infiltration; (Figures 3.A.1 and 3.A.2); and,
  - Minimizing run-off through the use of green roofs and permeable paving.
3. Maximizing the efficient use of potable water through design and management using techniques such as:
    - Using water efficient (low-flow) plumbing fixtures, dish-washers and clothes-washers, etc.;
    - Creating landscapes using native and other plants with low watering requirements, and efficient irrigation systems with automatic controllers; and,
    - Utilizing grey or recycled water for irrigation.
  4. Minimizing energy use through a variety of building construction and management techniques, such as:
    - Designing buildings to maximize natural lighting and ventilation;
    - Where feasible, employing building systems to recycle surplus energy, such as heat pump systems;
    - Encouraging the use of 100% Energy Star appliances;
    - Using passive solar techniques for natural heating and cooling;
    - Installing localized or zone heating and cooling systems and lighting controls;
    - Encouraging the use of energy efficient fluorescent lighting; and,
    - Use of photovoltaic (PV) energy sources integrated into building design where feasible.
  5. Using appropriate site and building materials that are resource efficient and that avoid health impacts to occupants, such as carpet glues with low Volatile Organic Compound (VOC) emissions.
  6. Taking into account near-term construction and design costs compared with potential longer-term maintenance and life-cycle cost benefits.

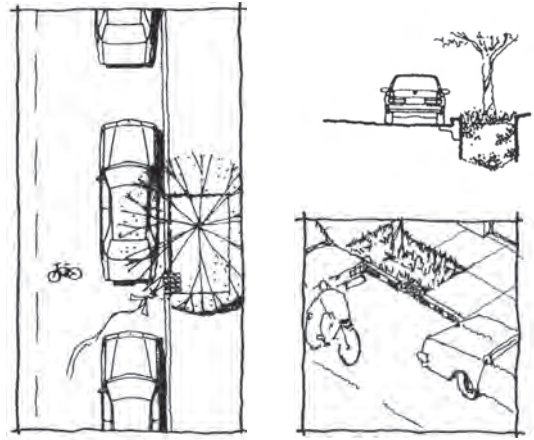

Figure 3.A.1: Innovative Solutions for Stormwater Crossings

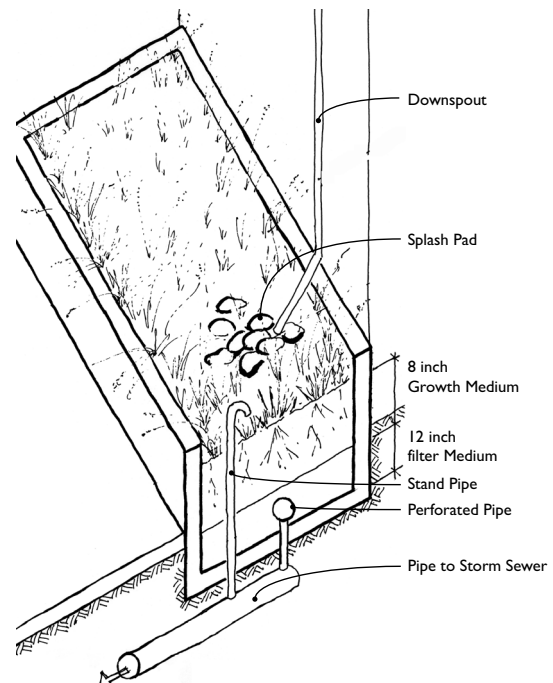

Figure 3.A.2: Raised planters can be used to provide benefits similar to swales.





Figure 3.A.3: Buildings should contribute to the public realm.



Figure 3.A.4: Buildings should create a direct relationship to sidewalks, plazas, and open spaces to take advantage of the activity in these spaces with ground floor retail or other active uses.



Figure 3.A.5: Residential uses should front sidewalks with primary entrances that incorporate porches, stoops, stairs, and the more active interior spaces.

## 2.2 Site Design and Building Orientation

The site design and orientation of buildings within the Waterfront should enliven the public spaces that are adjacent to them throughout the day and into the evening. By following these Guidelines, new development in the Waterfront will create a pedestrian-friendly and transit-supportive environment that strengthens the link between the businesses and residences in the Waterfront and the public spaces.

### 2.2.1 Relationship of Buildings to Streets and Open Spaces

To create successful places that encourage pedestrian activity and are attractive for residents and visitors, a strong and mutually supportive relationship between activity in the building and pedestrian activity outside needs to be established and maintained. Activity within the ground-floor of buildings can attract passers-by and provide “eyes-on-the-street” for the security of outdoor spaces. At the same time, pass-by pedestrian traffic that can see into the ground-floor of a building will be attracted to the activity within and will then be more likely to patronize the business. The relationship of buildings to public spaces should encourage this interaction.

#### 2.2.1.A Building Design

1. Buildings within the Vallejo Waterfront should directly orient towards the streets, sidewalks, parks, plazas and promenade that form the public realm.
2. The majority of building frontages should be built parallel to the street or around the edges of public plazas, promenades, or other public spaces to avoid creating ambiguous spaces that are devoid of human activity and that can become neglected over time. Recessed entryways may be an exception.
3. The use of blank and unarticulated walls should be avoided (Also see *Section III.A.2.3.1.B Façade Articulations and Wall Frontage* for blank wall Guidelines).



### 2.2.1.B Building Frontage

1. The more active uses in a building should front onto sidewalks and open spaces. For commercial buildings this includes storefronts, dining areas, office and hotel lobbies or other semi-public spaces within offices. For civic uses, this should be the front lobby and any retail component associated with the use. For residential uses, this includes lobbies, porches to individual unit entries, living rooms, dining rooms and the work portion of live-work units.
2. Uses that are ambiguous in terms of the amount of activity they might lend to public spaces, such as day care facilities, private offices, conference rooms, lunch spaces, and work rooms, may locate along secondary pedestrian routes such as interior plazas and circulation spaces, and interior open spaces (i.e., private courtyards).
3. Private amenities, such as private commercial and residential courtyards, and hotel and residential pools should be located within the interior of the block or development and not front public open spaces and streets at the ground level. See *Section III.A.2.2.4 Façade Articulations and Wall Frontage* for additional Guidelines.



*Figure 3.A.6: Some of the most active frontages are created by restaurants and cafes.*

### 2.2.2 Building Entries and Access

The location of entrances is important in making pedestrian access of primary importance. Main entrances to buildings that are directly located along sidewalks, public pedestrian routes such as the Promenade, and public open spaces emphasize walking access and encourage pedestrian activity. This will be particularly important within the Central Waterfront.

A hierarchy of entrances provides direction to persons approaching a building and can reinforce the importance of building frontages along the public right-of-way or open space. Primary entrances include: front doors to residences, residential and office lobbies, and storefronts. Secondary entrances include access to and from parking garages, utility areas, rear parking lots, and minor secondary entrances. For example, an office building could be designed to have a lobby that is accessed from the street as well as have a secondary entry from a parking garage or lot behind the building.



Figure 3.A.7: Corner entries emphasize important street and sidewalk intersections.

### 2.2.2.A Entry Orientation

1. The façade of a building that orients to a public street or publicly accessible open space, such as the Paseo Park or the Southern Waterfront Park, should contain the primary entrance(s) to the uses within the building.
2. Primary building entrances should directly front onto and connect to public sidewalks or the open spaces. Secondary entrances may face interior plazas and open spaces, alleys, and surface and structured parking lots.
3. Primary entrances are encouraged at street corners. Orienting primary entrances to street corners creates opportunities for more activity at intersections (See Figure 3.A.7).



Figure 3.A.8: Multi-family buildings can have individual unit entries accessed directly from the street.

### 2.2.2.B Entry Design

1. Residential, office, or hotel lobbies in mixed-use buildings should be clearly defined and distinct from commercial entries.
2. Ground-floor residential units oriented towards the street and or publicly accessible open space, such as the Paseo Park should have direct entrances from a sidewalk or a pedestrian route. In buildings that do not have ground-floor residential units, consideration should be given to providing stair access to stoops, porches, or loggias that provide more direct access from the street to units (See Figure 3.A.8).
3. Where buildings are set back from the street, hardscaped entry areas or plazas are encouraged between the entrance and the sidewalk or pedestrian route. These areas should include simple amenities such as benches, planters, seat walls, deciduous or ornamental trees, landscaping and trash cans. These areas provide meeting places, places to comfortably wait for a ride, and places to take a break and enjoy the urban environment.
4. Entry plazas should be proportioned to match the building type, use and entrance. For example, offices, and multi-unit residential lobbies should be intimate in scale, whereas the plaza for a hotel or Conference Center should be more civic and grand in scale (See Figure 3.A.9).



Figure 3.A.9: Plazas can create dynamic spaces where buildings are set back from the street.

### 2.2.2.C Entry Spacing

1. Frequent entries create the opportunity for a greater amount of activity and interaction along the sidewalk and encourage pedestrian activity. Conversely, infrequent entries create inactive and uninteresting spaces and can limit choices for pedestrians, requiring them to take circuitous paths. Additional detailed Guidelines for entry spacing are provided in the district-specific Guidelines sections (See Figure 3.A.10).



Figure 3.A.10: Frequent Entries

### 2.2.3 Visibility of Ground Floor Activity

In order to create an active and comfortable pedestrian environment, it is important to achieve a high level of “transparency” between ground floor uses and the pedestrian on the street. The visual interaction of activity within buildings and on the street also enhances safety and security in the public realm – “eyes-on-the-street.” Additionally, foot traffic that is able to visually connect with interior activity inside shop fronts, offices, and dining and drinking establishments benefits retailers with a ready means of advertising their goods and services. Visible lobbies allow pedestrians to easily locate and identify their destination. While more privacy is desirable for ground floor residences and offices, a transition can be made by introducing porches, courtyards, landscaping, or changes in grade to define public, semi-public, and private space.

1. Windows facing the street give a sense of habitation and security; therefore windows should be maximized at the street level or on floors directly fronting publicly accessible sidewalks and open spaces (See *Section III.A. 2.3.2.A Architectural Detailing: Windows* for minimum window frontage Guidelines).
2. Clear windows allowing 100% visual transparency (i.e., no excessive tinting or other characteristics that obscure activity within the building) should dominate the ground-floor building frontage of non-residential uses.



Figure 3.A.11: Transparency at the ground floor attracts window shoppers and passersby.





Figure 3.A.12: Outdoor dining enlivens sidewalks and other pedestrian spaces.

### 2.2.4 Outdoor Recreation, Dining and Display

Encouraging commercial uses such as retail stores, restaurants, and cafes to continue their activity outside of their interiors will greatly contribute to activating the Waterfront. Outdoor seating, tables, and displays encourages passers-by to patronize the stores, dine at the restaurants and stop for a drink.

1. Outdoor dining that is open to the public and outdoor retail displays are encouraged along public sidewalks throughout the Waterfront and open spaces such as the Festival Green. Such uses activate the public realm and provide an inviting frontage along pedestrian places.
2. Outdoor dining along retail frontages, including facilities associated with hotels, conference centers, or similar uses, should be designed to offer an inviting frontage to the street and public open space (See Figure 3.A.12).
3. Outdoor dining shall comply with the City of Vallejo’s “Outdoor Dining Performance Standards” as established in the City’s Zoning Ordinance (See Section III.A.2.3.3 *Detailed Design of Outdoor Dining and Display*).

### 2.2.5 Off-Street Parking and Drop-off Areas

The extent and location of parking has a great effect on both the viability of land uses developed in the area and on the pedestrian environment. While the automobile is likely to remain the primary mode of access for the foreseeable future, the mix of uses, particularly in the Central Waterfront with its proximity to downtown and transit (both ferry and bus), creates conditions for high accessibility by means other than automobiles. The Guidelines strive to strike a balance between auto, service, bicycle, pedestrian, and transit access.

#### 2.2.5.A Site Location

1. The extent of surface parking lots and structures that front onto a public sidewalk or open space should be minimized. Options for locations include: within the interior of the block (i.e., lined with more active uses along sidewalk and public open space frontages), underground, on the upper floors of buildings and along streets that are less frequented by pedestrians.

2. Parking lot and structure driveways should be located a minimum of 75 feet away from any intersection.
3. Effort should be made to consolidate driveways to minimize their impact on sidewalks and reduce conflicts with pedestrians as well as with vehicles and bicycles on adjacent streets. Minimizing driveways also creates more space for on-street parking, street trees, and street furnishings.
4. Drop-off areas, such as for hotels, should be located within the interior of the block in order to minimize the amount of paved area for automobiles along the sidewalk. Two-way driveways are preferred (if this reduces the number of curb cuts) and should follow maximum driveway widths and slope Guidelines at the sidewalk as outlined below.

### 2.2.5.B Driveway Design

1. Driveway and entry widths should be minimized in order to reduce their presence along streets. Curb cuts for two-way traffic should not be wider than 22 feet, except those that provide frequent access for large trucks. These should be no wider than 26 feet. One-directional driveways should be not wider than 12 feet. Dimensions are exclusive of pedestrian walkways.
2. Uneven pedestrian surfaces should be avoided. Driveway slopes that encroach on sidewalks make it difficult for pedestrians, persons with wheelchairs and strollers to navigate comfortably in a space that is meant for them. Driveway slopes should be located between the roadside edge of the sidewalk and the curb or within the property past the back of the sidewalk. This allows the surface of the sidewalk path to remain continuous and level. It also signals to the drivers that it is they who are crossing the pedestrian realm and must yield accordingly (See Figure 3.A.13).
3. Similarly, sidewalk paving patterns, color and materials should be continuous where they cross driveways to strengthen the understanding that this area is primarily a pedestrian realm.

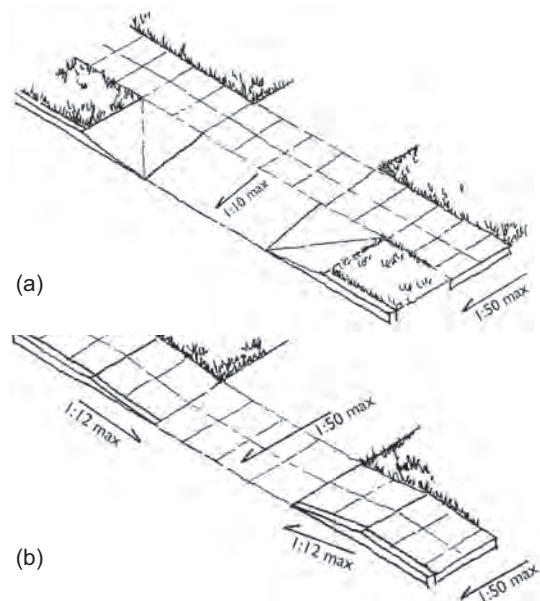

Figure 3.A.13 a and b: Figure a (top) is a preferred design for driveways where the sidewalk passes straight and level indicating the primacy of pedestrians. Where sidewalk widths are constrained, the design shown in Figure b (bottom) can be used.



*Figure 3.A.14: A walkway within a parking lot is made into an attractive and safe pedestrian route with a trellis, landscaping and illuminating bollards.*

### 2.2.5.C Interior Parking Walkways

Pedestrian walkways should be provided within the larger parking structures and surface lots to facilitate safe and convenient pedestrian circulation (See Figure 3.A.14).

1. In the design of parking structures and surface lots, walkways should be an integral part of the design process. Designs should comply with the most up-to-date ADA and Title 24 accessibility requirements.
2. Walkways should be raised to the standard sidewalk height of 6 inches and provide a minimum 5-foot clear width, exclusive of landscaping and car overhangs.
3. Where the path bisects auto travel lanes, crossings should be clearly delineated by a contrasting color, pattern, material change and/or be raised slightly to form a “speed table”.
4. Walkways should lead to meaningful destinations such as building entrances, sidewalks, plazas, open space and other parking lots, avoiding loading and service areas.
5. Within surface parking lots or the upper level of open parking structures, it is strongly recommended that walkways be shaded by trees or landscape structures to provide a comfortable pedestrian environment.

### 2.2.6 Off-Street Loading and Service Access

Building service areas are a necessary component to businesses and residences. However, inappropriate location and design can negatively impact the pedestrian experience if their relationship to the pedestrian realm is not given consideration during the design process. Early on in the design of a building and its siting, loading and service area location and design should also be coordinated with the appropriate service provider.

#### 2.2.6.A Site Location

1. All loading and service (e.g., refuse and recycling, utility, etc.) areas should be located and designed to minimize visual impacts and their presence along sidewalks, pedestrian corridors, and other public spaces.
2. Loading and service location should be accommodated within the building envelope or within parking



*Figure 3.A.15: A loading area is made attractive by incorporating it into the building design and minimizing its frontage along the sidewalk.*



structures. Consolidate facilities in order to minimize the area that is given to them and their necessary screening (See Figure 3.A.15).

3. Loading and service areas should not occupy more than 20 feet of building or street frontage.
4. Truck loading is allowed within off-street parking lots where loading cannot be accommodated within a building envelope; however, loading areas should not detract from the aesthetic quality of their surroundings even where they front onto parking lots.

### 2.2.6.B Design

1. Visible loading and service areas should be screened from view by an enclosure. Enclosures should be designed as an integral part of the building and should be made of finished materials compatible with the design of the primary building. The design of enclosures and screening should be coordinated with the appropriate agency responsible for the maintenance and servicing of the utility or meters.
2. In order to minimize the amount of paved area where trucks and autos must share access lanes and driveways, lanes and driveways should be designed to the minimum width for trucks, rather than aggregated into a combined width so that loading areas avoid adding to the paved area within off-street parking lots.
3. Delineation between loading and off-street parking should not solely use striping as it does little to minimize the amount of paving in the parking lot (See Figure 3.A.16). Instead, loading areas and access lanes should be physically separated from parking via curbs, bollards, low or high walls, raised planters, landscaping, distance and/or elevation changes in order to break up the perceived amount of paving.
4. Loading features such as bumper guards, doors, and elements for the protection of walls should be considered as part of the design of the building, not as an afterthought.
5. Clear right-of-way and parking restrictions signage should be provided where truck, auto, and pedestrian conflicts may occur within a parking lot or along the curb of a public street.



Figure 3.A.16: Aggregating the width of loading areas with auto driveways can create expansive paved surfaces that are unattractive pedestrian spaces.

## 2.3 Human Scale and Building Contribution to the Public Realm

Appropriate building scale, massing and height of buildings, combined with the quality and design of building articulation, materials, and detailing, will create an engaging pedestrian environment. This combination is critical in creating buildings that address a pedestrian aesthetic. Pedestrians travel at a much slower pace than automobiles and can comprehend a greater degree of complexity and interest in the landscape. In fact, this complexity is required to keep pedestrians engaged and interested in the surrounding environment, conveying to them that they are welcome in Vallejo’s Waterfront.

### 2.3.1 Building Form

Depending on the manner in which building scale and massing are handled in relation to articulation, materials, and architectural detailing, buildings can create engaging pedestrian environments or they can create forbidding and monotonous environments. Buildings that utilize form and massing as their main design elements simplify architecture to the extent that it does not engage pedestrians. Form alone cannot create interesting pedestrian environments. Form must be combined with articulation and architectural detailing. Yet form can create interesting spaces and places such as recesses that accommodate seating and balconies that overlook sidewalks.

#### 2.3.1.A Scale of Building Massing

1. Building form should follow a logical rhythm and order. Overly articulated building massing that is too complex can be chaotic and confusing, particularly for mixed-use buildings that should already create complexity with activity, fenestration, display, etc.
2. The massing of buildings should reflect and make visible the use and activity within the building. For example, the use of bays should reflect an interior change of use or function such as a dining room or a private office.
3. Buildings should avoid an overly horizontal look (See Figure 3.A.17). Where the overall massing of buildings is horizontal, elements of building form (e.g., bay windows, stairs, elevators, major entrances and architectural detail should provide vertical articulation. See also III.A.2.3.1.B: *Façade Scale and Variation Guidelines* for maximum wall segment Guidelines).



*Figure 3.A.17: (Example of Poor Design) An overly horizontal look paired with a lack of articulation and detail does not create a visually engaging building making perceived walking distances longer for pedestrians.*

**2.3.1.B Façade Scale and Variation Guidelines**

1. For multi-story buildings, the ground floor should be proportionally higher and architecturally distinguished from the upper façade to afford generous and inviting commercial spaces and to distinguish uses in mixed-use buildings (See Figure 3.A.18). Floor-to-ceiling heights should follow the Guidelines below (See Table 3.A.1).

Land Use	Minimum Floor-to-Ceiling Height
Ground-floor Retail and Live/Work, Office and Hotels	16 feet (18 feet desired for Live/Work to allow for mezzanine/loft level)
Ground-floor Residential	12 feet (in the Northern Waterfront 10 feet in order to maintain neighborhood scale of residential development)
Upper floors	10 feet

Table 3.A.1: Minimum Floor-to-Ceiling Heights

**Façade Scale – “Base, Middle, and Top”**

An important aspect of creating a human-scale to the public realm is to vary the façade such that the top and the bottom of a building are comprehensible to the person in scale and detail. Buildings that do not have a defined beginning and ending tend to look as if they are divorced from their physical environment, creating uninviting spaces.

1. In general, building form should provide a “base” and a “top” that are human-scaled in terms of form, height, and articulation (See Figure 3.A.19).
2. A well-defined “base” provides detail and articulation scaled to pedestrians that pass by the building façade providing a visual and tactile human-scale to the building. A distinct base also relates the building to the ground it is built on and the surrounding sidewalk. The “base” should consist of, but not be limited to, thicker walls, richly textured materials (i.e., tile or masonry treatments), special materials such as ceramic tile, granite and marble, and/or darker colored materials and/or panels.
3. A recognizable “top” provides a highlight, detail, or shadow line that caps the top of a building giving it a distinct termination. The “top” should consist of, but not be limited to, cornice treatments, roof overhangs with brackets, stepped parapets, richly textured materials (i.e., tile or masonry treatments), and/or differently colored materials.



Figure 3.A.18: Floor-to-ceiling heights at the ground-floor should be taller than upper floors.



Figure 3.A.19: A well-defined base, middle, and top grounds the building and creates a distinct and identifiable termination with articulated eave.





Figure 3.A.20: (Example of Poor Design) A blank wall can encourage graffiti and creates frontages that are devoid of interest and activity.



Figure 3.A.21: (Example of Poor Design) Color changes alone do not create attractive building façades. Articulation and architectural detailing should also be incorporated.



Figure 3.A.22: Artwork can effectively enliven spaces and mask blank walls.

### Façade Articulation and Wall Frontage

Façade articulation can create interesting spaces along building frontages where amenities such as seating, porches, small plazas and artwork may be placed to make the street environment more interesting or to accommodate activity that will filter between the building and the sidewalk. The amount of wall to window area is also important for creating interesting spaces. Figure 3.A.20 shows the potential negative impacts of a blank wall. Again, transparency is key along the ground floor of buildings so that interaction between interior and exterior is maximized.

1. Any section of blank wall in excess of 6 feet in length should include vertical articulation, such as a change in plane of the building wall, building material, architectural detailing, or other building elements. Solid walls under exterior stairs and stoops should be counted towards this Guideline.
2. Articulation and detailing should not consist solely of color changes without changes in material or planes, as color change alone does not create a feeling of permanence, real variety and interest, or interesting shadow lines (See Figure 3.A.21).
3. In no case should any façade consist of unarticulated blank walls.
4. Articulation of building façades should provide visual interest and shade in order to create an environment that is comfortable and appealing for pedestrians.
5. High quality artwork and landscape treatments are also encouraged along blank sections of walls (See Figure 3.A.22).
6. Where walls front onto a sidewalk, open space or the Paseo Park, maximum wall frontage should follow the Guidelines below:

Land Use	Maximum Length of Continuous Blank Wall Frontage (in linear feet)
Residential or Hotel/Conference Center	20
Other Uses	10

Table 3.A.2: Maximum Wall Segment on Publicly Accessible or Visible Façade

### Corners and Landmark Features

1. Buildings should directly address street corners, particularly at significant intersections, with main entrances and storefronts, entry plazas, vertical elements such as towers and/or other building or urban design elements. Any such elements should be proportioned to reflect the average height of the building and the span of the intersection (See Figure 3.A.23).
2. Massing at street corners should visually define the space of the intersection. If buildings do not come directly up to street corners, or corner setbacks, buildings must form a comfortable and interesting space for the public to use; buildings should not pull back from a corner in an arbitrary or haphazard manner.
3. Primary entrances are encouraged at street corners, as these are convenient spaces where pedestrian traffic converges.
4. Towers, as well as elements that are integral to the building (i.e., chimneys, stairs, entries, etc.), can be used to create landmark features. Landmark features should call out important elements such as entries or the corners of buildings.



Figure 3.A.23: A tower element provides a distinct architectural element at a street corner creating a memorable feature.



Figure 3.A.24: (Example of Poor Design) Roofs that are devoid of interest create abstract buildings that are less engaging to pedestrians.

### Rooflines

1. Roofs should not be cosmetic in character or appear to be “tacked on.” Roofs should be an integral part of the overall building design relating to entries, overall façade articulation and building massing. In general, the design and detailing of roofs should provide a sense of termination to the building façade (See Figure 3.A.25).
2. Flat roofs should be designed with an articulated parapet or cornice line. Trellises may also be used to provide a top for buildings, particularly in cases where residential roof decks are provided.
3. Sloping roofs should be designed to include a well-articulated overhanging eave.
4. The profile created by roof forms should be simple without unnecessary changes in plane. Roof configuration should reflect a building’s floor plan and massing



Figure 3.A.25: Articulated rooflines effectively terminate the building and provide interest.





Figure 3.A.26: Well articulated massing and façades, ample fenestration, and rhythm in architectural elements create an attractive residential frontage.



Figure 3.A.27: Exaggerated and over-sized architectural detailing creates caricature buildings.

5. Mansard roofs should be avoided as they typically result in a tacked on appearance.
6. The roofs of buildings on corner lots should give emphasis to the building corner (See Figure 3.A.23).

### 2.3.2 Building Articulation

Architectural detailing and materials (articulation), are key to creating buildings that engage the pedestrian. Intricate shadows, materials that are visibly complex and tactile, intimate spaces where people can rest and interact draw the attention of pedestrians into the space and attracts activity by engaging the eye and mind of users. Articulation creates a complexity in form, shadow, and activity and imbues a place with memorable qualities.

#### 2.3.2.A Architectural Detailing – Scale and Ornamentation

##### General Building Detailing

1. The details of building architecture are the most important elements in determining a building’s contribution to a human-scaled environment. Buildings should use detail and proportions that are scaled to the size and proportion of the human body to create a level of familiarity and comfort for pedestrians.
2. Provide articulation through human-scale elements (e.g., architectural detailing, fenestration, materials, and/or variation in materials).
3. Careful consideration should be given to the design of façades (i.e., scale and level of architectural detail) in order to attune buildings on both sides of a street and adjacent building walls so they are compatible with each other.
4. Façade elements (i.e., windows, doors, bays, joints, etc.) should display a logical rhythm and order. To the degree that it provides interest to the pedestrian, articulation should be simple in form and contain rhythm and order. This is desired, because an overly articulated and random environment can be visually confusing and fragmented, particularly in a mixed-use district where a complex level of activity is already occurring.

5. Side elevations facing public and private streets and pedestrian corridors should be treated in a similar manner as the primary front façade. “False” fronts should not be allowed. That is, all sides of a building visible from a public space should have a consistent style and use of articulation. For example, the primary exterior finishes should be used on all façades of a unit or building visible from a street, pedestrian corridor, park, plaza, or other public or semi-public space.
6. Special architectural features such as bay windows, balconies, verandahs, decorative roofs, and entry features may project into the building setback or public right-of-way. Overhead features should allow for a minimum 8-foot clear height above any sidewalk or walkway.
7. Buildings should not rely solely on building massing to create an architectural gesture. Simplifying buildings to this extent creates monotony and a lack of detail, which is not conducive to creating an interesting pedestrian environment.
8. Exaggerated and over-sized architectural detailing should not be allowed as this diminishes buildings to a “caricature” of desirable articulation (See Figure 3.A.27).
9. Where retail uses front onto streets and plazas with storefronts special care should be taken in the quality and detailing of construction, as pedestrians will pay particular attention to these façades as they window shop and stroll along the Waterfront’s streets. The degree of architectural detailing and material finish in storefronts should generally exceed that of other parts of a building, and should exceed normal standards of craftsmanship (See Figure 3.A.28).

### Entry Detailing

1. Primary entrances should be designed to include greater detail and ornamentation to give them a clear identity and separate them from minor entrances. They should be easily identifiable and clearly expressed and recessed or framed by sheltering elements such as awnings, canopies, arcades, porches, or porticos. This creates a protected space that allows people to comfortably pause before entering or leaving the building to stop and talk with someone or organize themselves (See Figure 3.A.29 and 3.A.30).



Figure 3.A.28: Articulation in the form of an integrated seatwall and an attractive display increase and enhance the interaction between pedestrians and their surroundings.



Figure 3.A.29: A well articulated primary residential entry is made distinct from storefront entries with color, change in materials and articulation.



Figure 3.A.30: An attractive entry feature announces the primary entrance and emphasizes the street corner.





Figure 3.A.31: Attractive Residential Stairs

2. Secondary entries should be treated in a similar, but lesser, manner as primary entrances.
3. The building address should be signed at the primary entrance.
4. Entries to retail shops should be located directly at the sidewalk level when possible. Ramps for ADA access should be located inside of the retail space and integrated into the design and layout of the shop.
5. Porches and stoops for residential units should be designed as an integral architectural feature of the main structure. Porches and stoops should be covered with a roof. See individual district sections for minimum porch and stoop area.
6. Residential stairs and railings should not create visual barriers. Railings should not be formed of solid walls, but instead be designed to provide filtered views of activity as people use the stairs. Solid walls under stairs should be articulated with architectural detailing, material changes, color or landscaping to avoid creating an uninteresting frontage along the street and sidewalk. Solid walls under stairs that are parallel to a street or plaza should be counted towards the blank wall restrictions (See III.A.2.3.1.B: Façade Scale and Variation Guidelines and Figure 3.A.31).

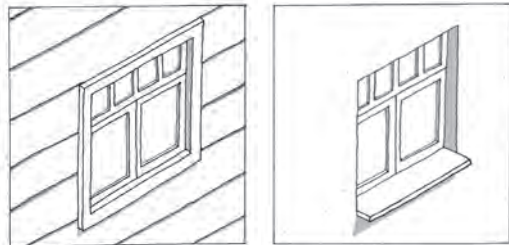

Figure 3.A.32: Window recesses cast complex shadow lines, creating interest that attracts the eye of pedestrians.

### Windows

Windows facing the street create a visual linkage between activity in the building and the street, giving a sense of habitation and security to the street. The positive aspects of “eyes-on-the-street” need to be balanced with desires for privacy for office workers and residents inside of buildings in the Waterfront.



Figure 3.A.33: (Example of Poor Design) Care must be taken to avoid situations where office blinds are frequently drawn to create some privacy.

1. Façades that front onto public streets and pedestrian corridors should be lined with windows. Upper story window frontage for various land uses should follow the Guidelines below:

Land Use	Minimum Window Frontage
Residential or Hotel	50%
Office and Conference Center (includes openings for parking structures)	60%
Retail or Live-Work	70%

Table 3.A.3: Minimum Window Frontage Guidelines

2. To give windows a more human proportion and relationship, they should be taller than they are wide. Transom windows, which are allowed, are not to be included in this measurement. An exception can be given to retail windows, where the use of mullions and other fenestration can be used to give a human-scale and proportion.
3. Windows and window frames set to provide a reveal are strongly encouraged (i.e., they should not be flush with the exterior wall) to provide a complexity of shadow and form along the façades of buildings. Windows should be recessed 1 to 3 inches from the external wall plane (See Figure 3.A.32).
4. Where offices occupy the ground floor of a building, the need for privacy should be balanced with the need to create a pedestrian-friendly street frontage. That is, the configuration of uses and design of a building should consider the tendency for some users to close blinds in order to maximize privacy.
5. Windows in office spaces should be designed with a sill height of 3-feet 6-inches that allows desks or low shelves to be placed against exterior walls rather than having lower sill heights, which often result in the backs of office furnishings and machines facing onto adjacent streets (See Figures 3.A.33 and 3.A.34). As an alternative to locating office windows on top of a wall/wainscot, office windows may have opaque panels in their lower sections, under 3-feet 6-inches, to screen desks and other office “clutter” while maintaining a visual connection between activity in the office space and the street.
6. Similarly, banks and financial institutions located at street-level often create blank wall conditions for security reasons by closing blinds or fronting sidewalks with large display advertisements. Security considerations need to be balanced with the need to maintain a pedestrian-friendly street frontage. Design solutions may include locating the bank at the interior of the building and allowing a lobby and customer activities to front the street (See Figure 3.A.35).
7. Careful consideration should be made of window and door signage, shading and screening devices, and interior displays such that transparency is not significantly diminished by these elements. Interior displays that are oriented only to the customer inside

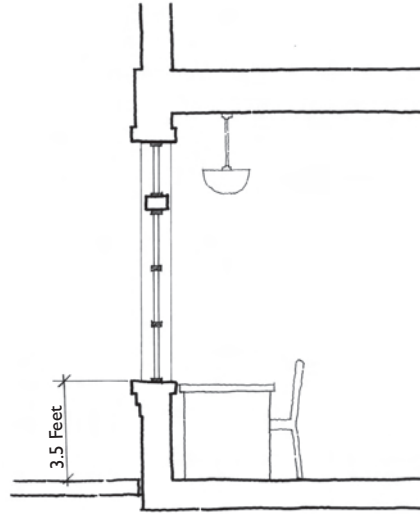

Figure 3.A.34: Keeping window sills at 3 feet 6 inches of the finish floor allows desks to be placed against window walls.



Figure 3.A.35: (Example of Poor Design) Banks often close blinds for security reasons creating blank walls at the ground floor.



Figure 3.A.36: An inviting entry attracts shoppers with a high level of architectural detailing and transparency.





Figure 3.A.37: Retail with High Ceiling and Transom Windows



Figure 3.A.38: Architectural canopies shade a window while creating attractive articulation on a building façade.

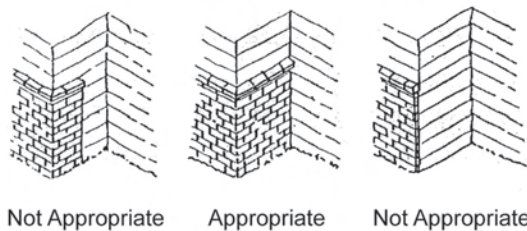

Figure 3.A.39: Material changes that do not occur at interior corners do not result in a sense of quality or care.

the store and not to the pedestrian do not support street life or encourage pedestrians to stop and shop (See Figure 3.A.36).

8. Shutters, operable or inoperable, should be sized to the window they are associated with such that, if closed, they cover the entire window.
9. Corner buildings should continue the window pattern around the corner of the building either for the entire length of each building façade or to a logical point such as an offset in the façade – the goal is to avoid “false-front” buildings.
10. Clerestory windows should not encompass the primary fenestration along a façade. For commercial and retail spaces with high ceilings the use of transom windows above storefront windows is encouraged (See Figure 3.A.37).
11. For privacy reasons, side elevation windows, particularly for residential uses, should be placed to offset from windows of adjacent residential units.
12. Window design should maximize interior daylighting while reducing glare through the use of passive shading devices that maintain visibility between the exterior and interior of the building. Methods can include: “special E” glass technologies, deep overhangs or external sun shades and trees. Reflective or tinted glazing should be prohibited as it tends to create uncomfortably bright environments along sidewalks and reduces the visibility of interior activity (See Figure 3.A.38).

### Building Materials and Finishes

The use of high-quality materials on buildings imparts to the public that a place is valued, well-cared for, and respected. Buildings made of high-quality materials convey a sense of permanence and respond to the pedestrian-scale, much like what is found in Vallejo’s Downtown and nearby residential neighborhoods.

1. A variety of building finishes and materials are desirable in creating pedestrian-supportive architecture. Specific recommended building materials and finishes are described in each of the district-specific sections of the Guidelines.
2. The following materials and finishes are generally inappropriate, because they do not achieve the quality or



life-span desired for the Waterfront, they are inappropriate in terms of style, they do not achieve visibility and other goals of the Design Guidelines, or they are obviously simulating other higher-quality building materials:

- a. coarsely finished or rustic materials, such as wood shakes, shingles, fir plywood, textured plywood or T-111;
  - b. Indoor-outdoor carpeting, astro-turf, or other simulated landscaping;
  - c. Corrugated or expanded metal, except as part of a design feature or detail;
  - d. Corrugated fiberglass;
  - e. Imitation masonry and stone materials or panels;
  - f. Silver, clear, or brightly anodized aluminum sheets, or extrusions for windows or doorways, with the exception of storefronts;
  - g. Plastic molded or foam imitations of conventional building materials;
  - h. Mirrored glass, metallic reflective glass, or glass that is overly tinted (See Figure 3.A.40); and,
  - i. Glass block, except as a limited part of a design feature or detail.
3. To give buildings an authentic appearance, as opposed to a veneer-like quality, material changes should not occur at external corners. Rather, they should occur at interior corners or at a change in horizontal plane (See Figure 3.A.39).
  4. The amount of reflective building materials should be very limited or prohibited on development directly abutting a pedestrian way. Highly reflective material, such as mirrored window walls, may help to keep interior temperatures down, but can be extremely uncomfortable for the pedestrian passing by. Other affordable and effective means of energy efficient design are readily available.
  5. Wood, vinyl clad, vinyl, and multi-paned metal windows are strongly encouraged to impart a sense of permanence and a high quality of design. On the other hand, horizontal “slider” windows and window frames with metallic finishes are strongly discouraged. Multi-paned windows, with the exception of “snap-in” plastic mullions, are preferred as they contribute to a level of detail and complexity that creates a good pedestrian environment.



*Figure 3.A.40: (Example of Poor Design) Opaque and reflective glass can create a blank façade along sidewalks and pedestrian spaces.*

### **Weather and Wind Protection**

The waterfront provides the area with a unique opportunity for creating a strong sense of character and to provide open views to the Mare Island Strait and Mare Island. At the same time, its exposure to the Strait creates windy conditions that have the potential for creating uncomfortable pedestrian spaces. Wind, as well as general weather protection, should be considered in the design of buildings and their surrounding environment.

#### **Wind Protection**

1. Glass barriers for residential balconies that protect residents from windy conditions are allowed, but should not be “tacked on.” Instead, barriers and other protective devices should be well articulated, made of high-quality materials and be designed as an integral feature to the building.

#### **Awnings and Overhangs**

1. Respect the architectural integrity of the façade on which these attachments are placed and the context of the building’s location. Awnings and canopies should be proportional to the façade of the building and not obscure architectural elements and details. Awnings and canopies should not be dominant or overwhelming elements
2. Awnings should be no wider than a single storefront or architectural bay, whichever is narrower. Colors should be consistent with the overall palette of the development.
3. The height of awnings and canopies should provide pedestrian-scale to the building and also meet code requirements. Awnings and canopies should be at least 8 feet above the sidewalk, and may project no more than 2/3 of the width of the sidewalk or a maximum of 10 feet. Valances on the edge of an awning parallel to the building face should not be more than 12 inches wide.
4. Canvas awnings, and glass and metal canopies are encouraged, but their styles and designs must be consistent with the architectural style of the building and the character along the street. Vinyl, fiberglass, plastic, and internally or back-lit awnings are not allowed (See Figures 3.A.41 and 3.A.42).
5. Retractable or open sided awnings are preferred.



*Figure 3.A.41: Glass and metal canopy complements the contemporary architecture of this building and provides protection from rain at the building entrance.*



*Figure 3.A.42: Canvas awnings along these shop fronts provide a comfortable and shaded space for pedestrians to sit and rest, eat, or watch activity along the sidewalk.*

### Building Lighting

Lighting is a key element not only in creating comfortable and safe pedestrian spaces, lighting can also enhance and create interest in the surrounding environment. Good lighting design enhances the architecture of a building without creating bright glare along pedestrian spaces or onto adjacent properties. Lighting can highlight important building features and provide direction for pedestrians.

1. All exterior lighting should be an integral part of a building's architectural design.
2. All exterior lighting should be designed so as to not produce glare onto pedestrian spaces and adjacent uses.
3. Exterior lighting should generally be shielded and directed downward on the site, although up-lighting and other lighting of buildings is allowed if there is not a detrimental effect on adjacent uses, particularly residential uses, and pedestrian spaces.
4. Storefront lighting should be located and angled to ensure that they light merchandise rather than point towards windows or cause reflections or glare.
5. Retailers should consider providing after hours lighting within display and storefront areas, particularly in more active areas adjacent to Downtown Vallejo and the Ferry Terminal area along Mare Island Way. This lighting will highlight the retail shops and restaurants and contribute to pedestrian lighting, as well as encourage street activity and safety into the evening.

#### 2.3.3 Detailed Design of Outdoor Dining and Display

Outdoor dining and display shall comply with the City of Vallejo's "Outdoor Dining Performance Standards" as established in the City's Zoning Ordinance.

1. For restaurants and cafés, consideration should be given to providing window walls that can be opened to the street and open spaces to create indoor/outdoor-dining opportunities and allow the interior activities of these uses to activate public sidewalks and open spaces (See Figure 3.A.44).



Figure 3.A.43: Effective building lighting can highlight architectural features and create a comfortable and safe pedestrian environment.



Figure 3.A.44: Restaurants with operable window walls allow interior activity to spill out onto sidewalks and open spaces, encouraging a high level of interaction between the public and private realms.



2. When these uses must be separated from the public sidewalk or open space, low walls, railings, or hedges should be used. The height of these features should not exceed 3 feet and should be designed to match the primary building with which they are associated (See *Section III.C.2.2 Circulation Guidelines and Section III.B.2.2 Circulation Guidelines*, for specific sidewalk widths).
3. Outdoor display is encouraged along retail frontages in order to activate the street.

### 2.3.4 Transition from Public Realm to Interior Space

To create an inviting building frontage along sidewalks and open spaces, building frontages should include a recognizable series of zones transitioning from public to private rather than an abrupt separation which occurs when a blank wall constitutes the majority of a building's street front, or when the more private portions of a use such as private office or bedroom, front a public space. Porches, large windows, stairs, and welcoming entryways provide opportunities for a friendly transition between public and private spaces.



*Figure 3.A.45: A well-defined primary entrance combined with an appropriately scaled entry plaza to this multi-family building makes the entry inviting and easy to find.*

1. Sidewalks and other pedestrian routes should be fronted by the more public rooms of adjacent buildings such as lobbies, eating areas, lunchrooms, the work portion of a live/work unit, and the front hallway, living room, dining room or kitchen of a residential unit.
2. The interior of live-work units should be designed such that the work portion of the unit acts as the semi-public space that buffers the residential portion of the unit.
3. At a minimum, front façades of residential buildings should be articulated with a porch, stoop or a defined lobby entry to create a friendly transition between the public realm of the street and the private realm of the unit. Bay windows and balconies are encouraged. Wrap-around porches and wrap-around balconies are encouraged on corner units.
4. Where street-facing residential units are set back less than 6 feet from a public right-of-way, first floor units should be designed with additional measures to

ensure privacy that is balanced with the need to create a pedestrian-friendly frontage. For example, windowsill heights should be raised above the eye level of a passing pedestrian. Elevated stoops and planters and raising interior floor elevations above adjacent sidewalk grade are some measures that can be employed. However, interior finished floor elevations should be no higher than 4 feet above the sidewalk whenever possible.

5. Façades set back more than 6 feet from the sidewalk or other pedestrian route should be designed to create a pedestrian-friendly frontage. Designs could include low walls and fences (no higher than 3-feet 6-inches), entry features such as arbors, gates, courtyards, and walkways, and lighting and landscaping.

### 2.3.5 Utilities and Mechanical Equipment

Utilities and mechanical equipment are integral components for the proper function of buildings. These building components should be carefully located and designed so as to not detract from the aesthetics of the public spaces within the Waterfront project.

1. Utilities and mechanical equipment, such as meters, roof-mounted equipment, and A/C units, should be located to minimize visual impacts and their presence along streets, sidewalks and public open spaces. Utilities and mechanical equipment should be located within buildings and parking structures, below grade, and/or carefully located away from active pedestrian routes and visible areas to the greatest extent possible.
2. The location, spacing, and screening of rooftop mechanical equipment should be incorporated into the general roof and building design.
3. Building utilities such as plumbing and heating vents should be grouped to minimize their visual impact on the roofs of buildings.
4. Where it is infeasible to locate utilities and mechanical equipment into the building envelope, they should be screened from view of pedestrians. Screening of such elements should occur in ways harmonious with the building design, or as artwork integrated in the building design (See Section III.A.2.2.6 *Off-Street Loading and Service Access* for screening Guidelines for outdoor utilities).

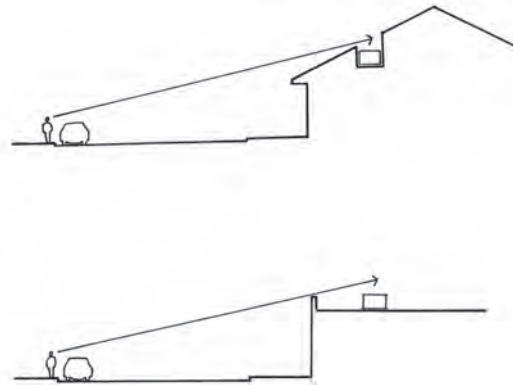

Figure 3.A.46: Mechanical equipment can be accommodated within rooflines or behind parapets.



### 2.3.6 Signage

Building signage can be one of the most prominent elements of the pedestrian environment, particularly where retail uses line the street. Signs can create a sense of interest and activity, and provide a human-scale to the street environment. At the same time, there is typically an inclination by retailers to allow signs to dominate the street environment. To maintain the desired qualities of the Waterfront it is important that signage is designed in response to the following Guidelines.

1. Signage should follow a hierarchy that clearly indicates the importance of the associated use, building, or place pedestrian-oriented signs should be small in size and highly individualized, whereas civic and landmark signage (e.g., performing arts center, district signs, signage for the Ferry Terminal, etc.) may be larger in size to announce an important place, gateway, or feature.
2. Prominent use or expressions of corporate logos should be avoided in the design of signage or buildings.
3. Signage dimensions should be kept at a pedestrian scale and should demonstrate a high level of detailing and craftsmanship.
4. Signage should reflect the character of the building and should be integrated within its architecture (See Figure 3.A.47).
5. Signs should not obscure architectural elements such as transom windows or columns, nor appear cluttered.
6. Flexibility should be allowed for artisans and craftspeople who wish to create unique signage that may contribute to the sense of place in the waterfront or tie into the Downtown character (See Figure 3.A.48).
7. Signage should be coordinated and aligned with adjacent and surrounding buildings in order to achieve a unified appearance rather than visual confusion. They should also respect the immediate context of the building's location, and the character along the street it is on (See Figure 3.A.49).
8. Signs should be constructed of high quality materials such as metal, stone, or wood.



Figure 3.A.47: Pedestrian-oriented signs should display a high level of detail. Bright colors and interesting forms can still create a connection with drivers.



Figure 3.A.48: Whimsical signs attract pedestrians with unique designs and contribute to creating memorable places.

9. Externally illuminated signs should be designed and installed so that their lighting elements are directed at the sign and not pedestrians, to minimize glare. Internally illuminated signs are strongly discouraged, because they are typically designed to attract drivers and are too intense and glaring for pedestrians. Blinking or flashing signs are discouraged.
10. Permitted signage includes: awning signs, hanging or projecting signs, signs integral to the architecture of a building, and window signs.
11. Window signs should not dominate a storefront. Opaque signage is strongly discouraged and should not reduce visual transparency of street-fronting windows to less than the minimum window frontage requirements defined in Table 3.A.3.
12. Sale signs and other temporary signs should not dominate a site in terms of size, color, light, etc. Figure 3.A.50 shows how temporary signs can dominate a façade.
13. Signage above the eave of the roofs and pole-mounted signs are strongly discouraged. Such signs are typical of many auto-oriented settings, which require larger signs to attract the attention of moving traffic.



Figure 3.A.49: Signage that is harmonious with a building's architecture does not detract from its appearance, but contributes to the overall design.



Figure 3.A.50: (Example of Poor Design) Care should be taken so that window signage does not overwhelm the street frontage, eliminate transparency, or create a chaotic and unattractive environment.

This Page Intentionally Left Blank

## B. Southern Waterfront District

### 1. District Character and Context

The future character of the Southern Waterfront District will be determined largely by future new development rather than its current context, with exception of the existing maritime uses (public boat launch). As with all Waterfront Districts, the most critical assets of the District are its exceptional views of Mare Island Strait and the opportunity for creating a public park along the waterfront with direct pedestrian, bicycle, and vehicular linkages between this portion of the Waterfront and the Downtown (via Marin Street), as well as other parks and segments of the Promenade located in the Northern and Central Waterfront Districts (Figure 3.B.1).

The character of this District will be less intensive compared with the Central Waterfront, but contain a similar mix of uses; however, uses will be mixed horizontally rather than vertically. From north to south the District will transition from a mixed-use commercial and public character to residential and then to a more industrial character at its southern end, where sites for research and development/light industrial buildings and a postal facility provide a transition to the heavier industrial uses farther to the south and outside of the planning area (See Figure 3.B.2).

Residential frontages along Sonoma Boulevard (State Route 29) and Curtola Parkway will have strong landscape edges to offset the development from the higher speeds and volumes of traffic on these roads while providing views into and potentially through the site from the intersection of Sonoma Boulevard and Curtola Parkway. Overall, residential and other uses are strongly oriented towards the new Waterfront Park and the Marin Street extension, which provides a strong linkage between the District and the Downtown. The linkage to the Downtown is also signified by the mixed-use (retail/office) building at the corner of Marin Street and Mare Island Way.

The District will not have as much pedestrian traffic as the Central Waterfront, because of the lower intensity of development both in the District and around it. This will result in a “quieter” environment and support the Design Guidelines’ approach of creating a more naturalistic design for its open spaces. The public open space program also includes a public boat launch and a bait shop, which cater to recreational fishing and boating activities.

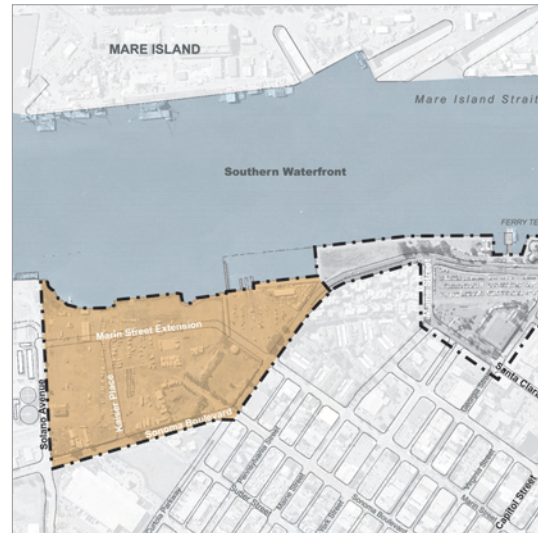

Figure 3.B.1: Southern Waterfront District Location

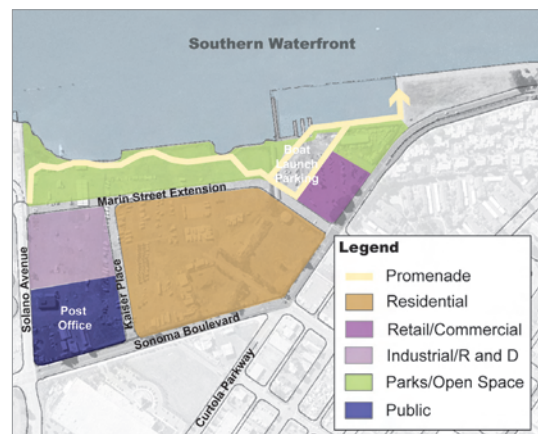

Figure 3.B.2: Land Use Diagram for Southern District



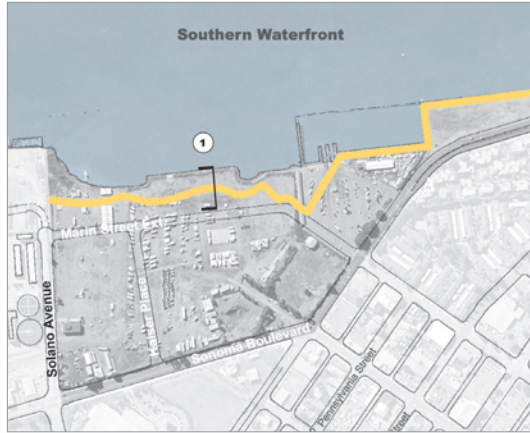

Figure 3.B.3: Promenade Section Location Diagram

## 2. Public Realm Guidelines

### 2.1 Waterfront Promenade, Parks, and Open Space Guidelines

This section provides Guidelines for these important public spaces and also includes several concept sketches that are illustrative of the intent of the Guidelines.

#### 2.1.1 Waterfront Promenade Design Elements

Overall, the Waterfront Promenade in the Southern Waterfront District is envisioned as less formal in character as compared to the “hard edged” seawall section of the Promenade in the Central Waterfront (which does extend into the northern portion of the Southern Waterfront District up to the boat launch). In the riprap-edged section of the Southern Waterfront, the path does not have to simultaneously form an edge against the water—a condition that lends itself to defining the Promenade more as a path in the park. This is supported by the recommendation of a more naturalistic landscape design for the Southern Waterfront Park, and may include the use of more native plants than in other landscaped areas of the Waterfront. At the same time, visually strong connections should be provided between the park, Promenade, and the development east of the Marin Street extension.



Figure 3.B.4 illustrates a prototypical cross section for the Promenade in the Southern Waterfront, which at 14 feet wide, can be used as an informal multi-purpose trail that also serves bicyclists. The sense of safety for Promenade users should be raised by locating the “Promenade #1” pedestrian-scale fixture alongside the path at approximately 40 feet on center. Furnishings, such as trash receptacles and benches should be selected from the “Waterfront” palette described in *Section II.B.1 Streetscape Elements*.

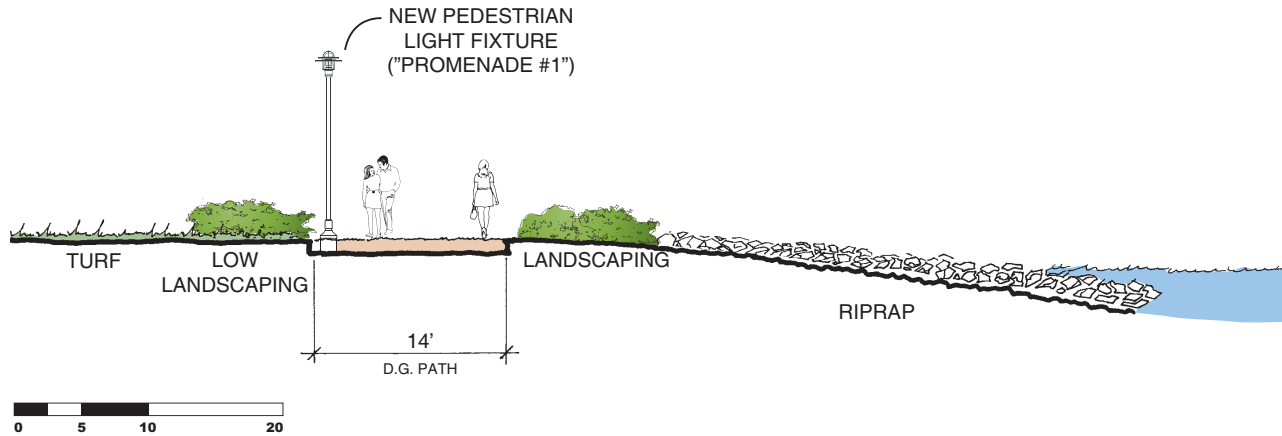

Figure 3.B.4: Section of Promenade in Southern Waterfront (typical)

### 2.1.2 Parks and Open Space

This section of the Guidelines provides specific guidance for the design of key open spaces within the Southern Waterfront District. It includes improvement diagrams and key Guidelines that give direction regarding the critical aspects of future improvements, as well as sketch concepts of sample improvements as they might result from the Guidelines.

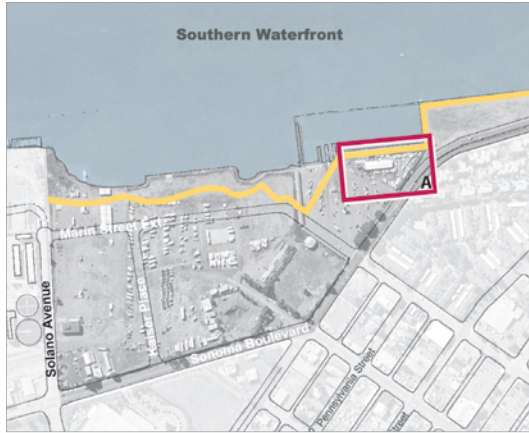

Figure 3.B.5: Area A Key Map

### Southern Waterfront Area A

This area is located between the Promenade, Mare Island Way, the parking lot for the new mixed-use commercial development and the boat launch (Figure 3.B.5). This area is currently fenced-off and inaccessible from the Promenade, as it is a private use. Improvements in this area should create an open green space with a focal point at its center while providing pedestrian access from both the Promenade and the adjacent parking lot (Figure 3.B.6). The existing bait shop in this area should be relocated to one of two potential locations further south in Area B, as discussed below.

### Guidelines

1. Create an area at the center of Area A as a focus to the open space. This can be achieved using features such as special paving, planters, clusters of small columnar trees or a relatively small gazebo or other structure. If a structure is used it should be designed with an open, visually permeable exterior to avoid blocking views.
2. Seating should be provided within the focal feature or just adjacent to it, as shown in the conceptual design illustrated in Figure 3.B.7. The seating should provide views of the waterfront, which may be achieved through light berming of the ground plane or otherwise built-up seating areas.

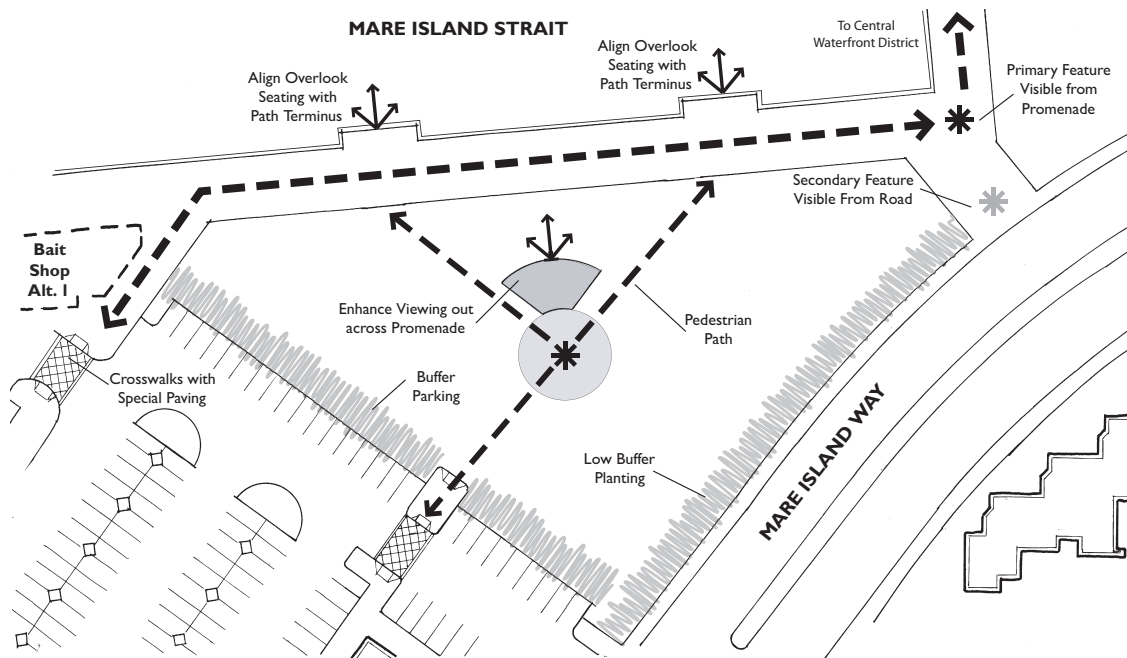

Figure 3.B.6: Area A Guideline Diagram

3. Provide crosswalks with special paving within the parking lot adjacent to Area A at the locations indicated in the diagram.
4. Create internal pedestrian circulation routes through Area A that connect from the parking lot adjacent to the central focal area and the Promenade, to the pedestrian circulation adjacent to the new mixed-use building.
5. Pedestrian paths within the park should be aligned with pedestrian crosswalks and Overlooks along the Promenade.
6. Provide buffer landscaping along adjacent surface parking lots in accordance with Guidelines in *Section III.B.3.1.4 Off-Street Parking Areas*. Buffer landscaping should include small trees along the southeast edge of Area A.
7. Provide a visual buffer consisting of low shrubs and plantings along the northeast edge of Area A, between it and Mare Island Way.
8. Use the standard “Waterfront” light fixture and street furnishings along Mare Island Way, and the standard “Promenade #1” light fixture and “Waterfront” furnishings along the Promenade.
9. Maintain unobstructed views along the western edge of the Promenade.

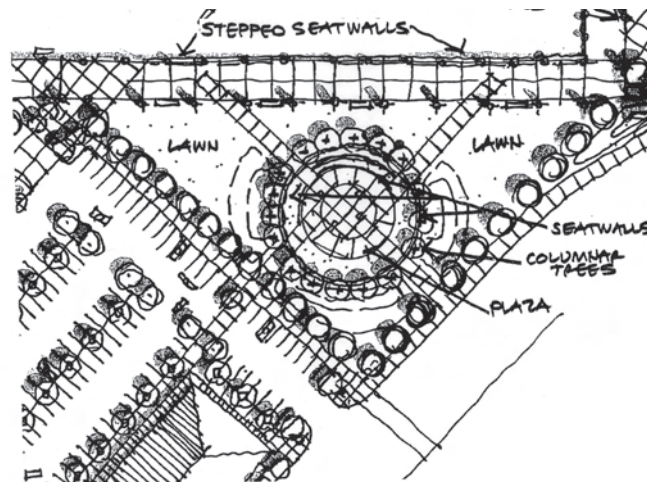

Figure 3.B.7: Sketch Concept for Area A

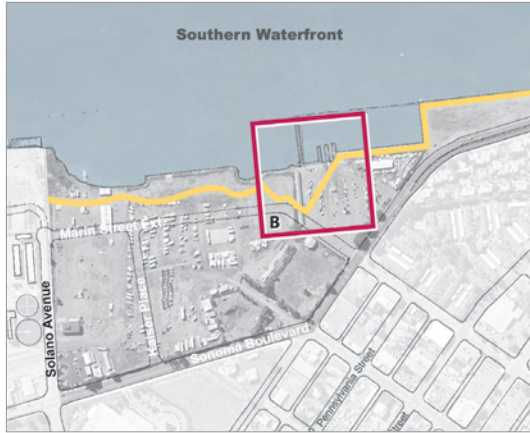

Figure 3.B.8: Area B Key Map

### Southern Waterfront Area B

Area B currently consists of a surface parking lot, a public boat launch and attendant parking areas, and vacant land (Figure 3.B.8). The Waterfront Promenade terminates in this area where the public boat launch creates a barrier to pedestrian circulation along the water’s edge. Open space improvements for Area B should specifically address pedestrian circulation that provides a continuation of the Promenade at appropriate widths and an additional circulation option across the boat launch area, as illustrated in Figure 3.B.9. The design of the Promenade in this area needs to be coordinated with the proposed future mixed-use building at the corner of Mare Island Way and the Marin Street extension and the parking lots associated with the mixed-use building, the boat launch, and the relocated bait shop.

### Guidelines

1. Create a primary pedestrian connection through Area B and around the boat launch area as illustrated in Figures 3.B.9 and 3.B.10.
2. Create a secondary pedestrian connection directly along the Waterfront and across the boat launch facility. This connection should include a specially paved or marked area along the edge of the boat slips to warn pedestrians of potential conflicts with boats and trailers at the water’s edge.

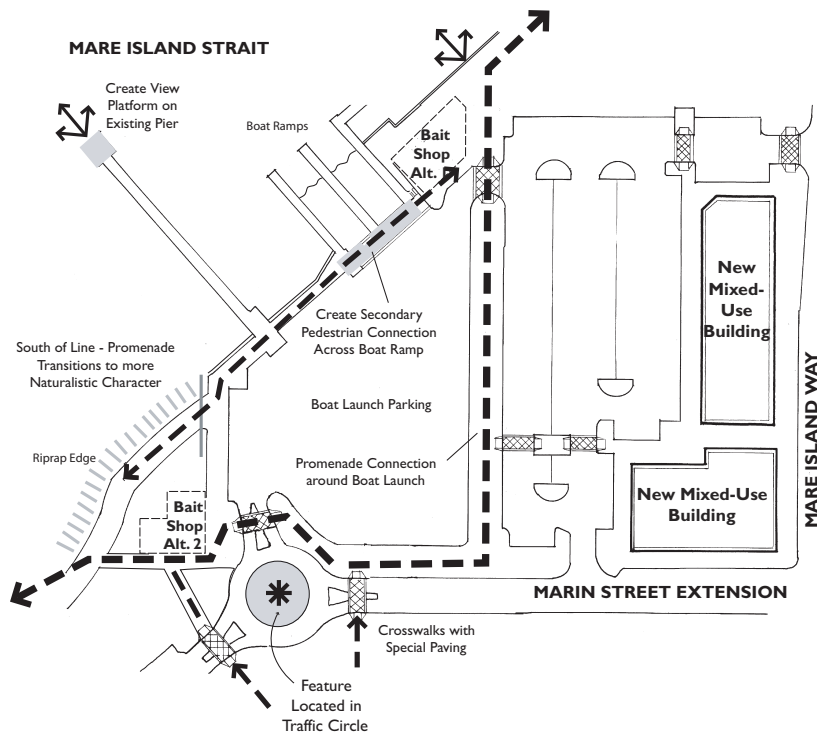

Figure 3.B.9: Area B Guideline Diagram

3. Provide buffer landscaping along adjacent surface parking lots in accordance with Guidelines in *Section III.B.3.1.4 Off-Street Parking Areas*. Buffer landscaping should include rows of trees on either side of the Promenade where it runs between the surface parking lots of the mixed-use building and the boat launch.
4. Install a feature, such as public art, in the center of the proposed traffic circle at the boat launch entrance on the Marin Street extension (if this option is chosen over the three-way stop intersection). This feature should be visible to both pedestrians and motorists and should draw attention to the vehicle and pedestrian access to the Waterfront at this location.
5. The existing bait shop should be relocated from its current site in Area A to one of two alternative locations in Area B. Both potential locations are illustrated in Figure 3.B.9. The proposed relocation of the bait shop will enhance the area by either marking the “deflection” of the Promenade away from the water’s edge (Alternative 1), or by anchoring the beginning of the more naturalistic and meandering portion of the Promenade to the south (Alternative 2).
6. Enhance viewing opportunities from the area by creating a platform at the end of the existing pier.
7. Promenade and secondary paths of the Waterfront Park south of the line indicated in Figure 3.B.9 should be surfaced with decomposed granite as opposed to concrete or asphalt.
8. Use the standard “Promenade #1” light fixture and “Waterfront” furnishings along the Promenade. Discontinue use of other fixtures along the Marin Street extension where this street’s sidewalk and the Promenade coincide.

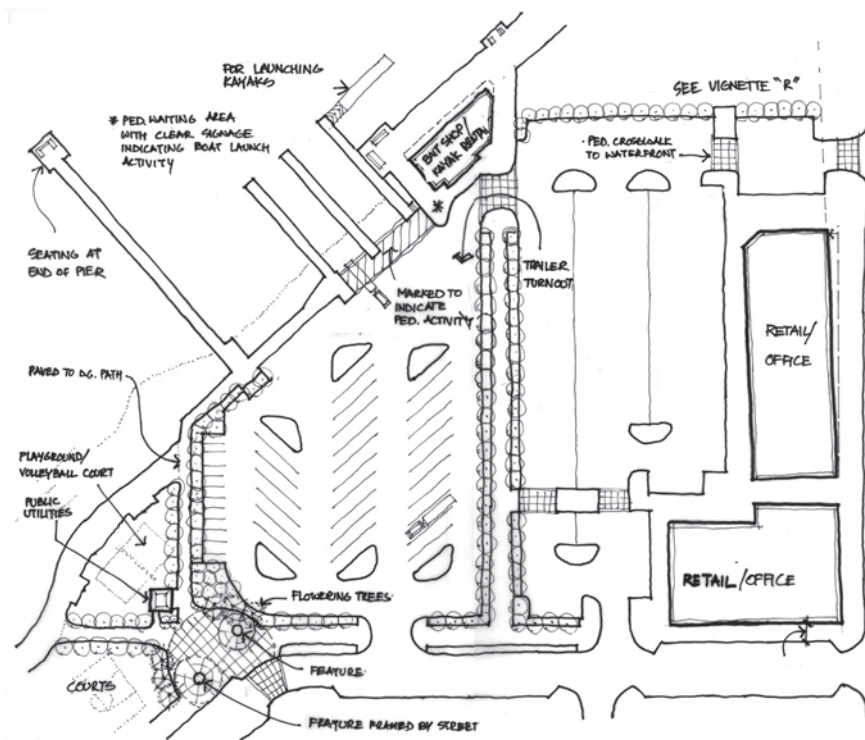

Figure 3.B.10: Sketch Concept for Area B



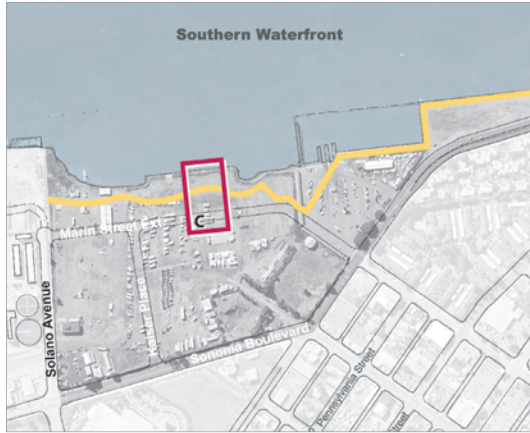

Figure 3.B.11: Area C Key Map

### Southern Waterfront Area C

In the future, when residential and commercial uses occupy the Southern Waterfront District, safe crossings of the Marin Street extension and direct access to the amenities of the park should be provided for residents and employees. The character of the Waterfront in these locations is intended to be less formal than in the Central Waterfront. The concepts expressed in Figure 3.B.12 can be applied to any of the mid-block crossings along the Marin Street extension, and, with some modifications, the future intersection of this street with Kaiser Place. In general, the intent is to create visible extensions for pedestrian access and views to the Waterfront from key pedestrian access points along the Marin Street extension.

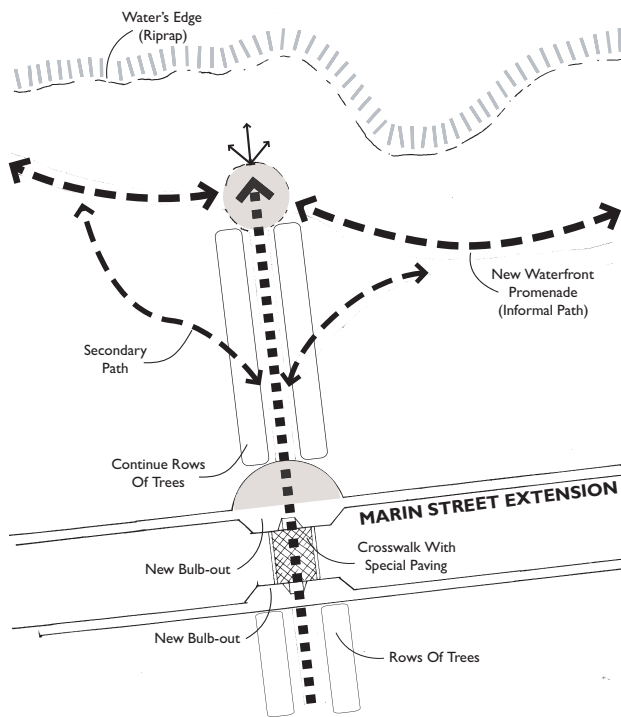

Figure 3.B.12: Area C Guideline Diagram

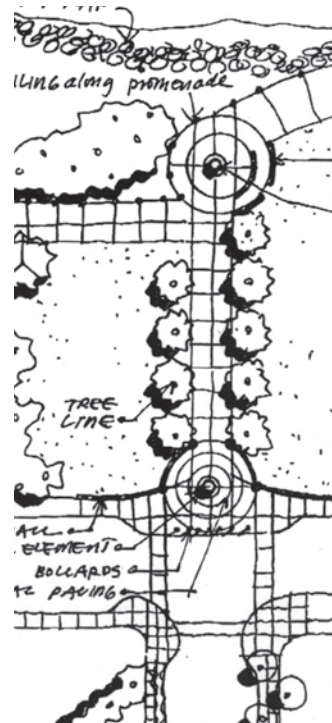

Figure 3.B.13: Sketch Concept for Area C

### Guidelines

1. Create safe and highly visible pedestrian crossings at key mid-block locations at the intersection of Kaiser Place and the Marin Street extension. These improvements should include bulb-outs on the east and west side of the Marin Street extension and crosswalks with special paving.
2. Provide a distinct entry into the Park at these locations. This may include the use of special paving and/or distinct planting.
3. A direct pedestrian path and view corridor from the crosswalks and entry areas to the Waterfront and a focal point should be provided. The focal point could consist of a thin vertical element, public art, or other special design feature that is not an impediment to the view, but that is visible as one walks along the Marin Street extension.
4. Rows of street trees planted along Kaiser Place or trees along pathways coming from the residential area out to the Marin Street extension should be extended on both sides of the pedestrian path through the park; these need not extend all the way through the Park. This will increase the visibility of the connection from the waterfront path and the street while framing views of the water from Solano Avenue.
5. Create a focal point and informal viewing spot located where the Promenade and access path intersect. The focal point should align with the crosswalks on the Marin Street extension. A focal point may consist of special paving, clusters of trees, or distinct landscaping (See conceptual plan in Figure 3.B.13).
6. Informal, secondary paths may branch off of the direct pedestrian connection between the focal point and crossings at the Marin Street extension, as illustrated in Figure 3.B.12.
7. Use the standard “Promenade #1” light fixture and “Waterfront” furnishings along the Promenade.

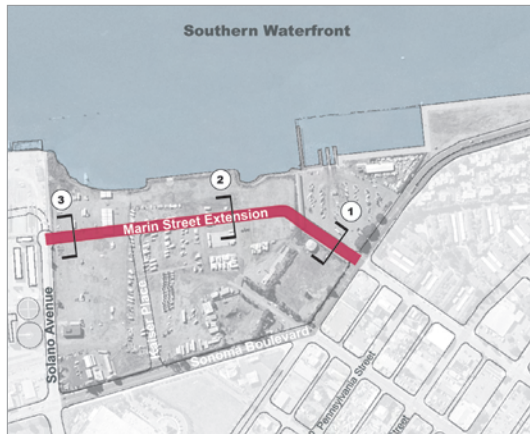

Figure 3.B.14: Marin Street Extension and Section Location Diagram

## 2.2 Circulation Guidelines

### 2.2.1 Street Guidelines

The following sections describe the design concepts for the streets in the Southern Waterfront, both new roads and existing roads that will be improved. The street trees that have been identified for use on these streets are described in *Section II B.2 Trees for Waterfront Streets*.

#### 2.2.1.A The Marin Street Extension

The proposed Marin Street Extension not only provides access to new residential, retail, and industrial/research and development uses, but also to marina facilities, such as the boat launch, future open spaces and the Promenade extension in the Southern Waterfront District. Through the link to Solano Avenue at its southern end, uses along the Marin Street Extension can also be accessed from areas to the east of Highway 29.

High levels of pedestrian activity are expected on this street because of its linkages to future waterfront destinations, as well as new and existing residential areas. The waterfront destinations also create “desire lines” for pedestrian travel across the Marin Street extension in several locations. It is therefore critical that the travel speed of vehicular traffic is kept appropriately low (at 25 mph), and that high-visibility pedestrian crossings with curb extension be included in the street’s design.

Figures 3.B.15 through 3.B.17 illustrate the proposed sections for the Marin Street extension. The roadway between the curbs is consistently configured to accommodate trucks with boat trailers in tow and the on-street parking needs of such vehicles. The design of the street section beyond the curbs, however, changes according to the adjoining land uses along residential uses. A setback of 33.5 feet between the face-of-curb and residential buildings provides a pleasant and comfortable walking environment that includes a landscape strip along the edge of the street as well as a landscaped front yard that is separated from the sidewalk by a low wall with a trellis or a low fence. This setback also provides a good balance between the desired privacy for ground level residences, maintaining high-quality views from the residences’ porches to the park and Mare Island Strait, and providing an element of safety for the area with “eyes-on-the-street” and park (Figures 3.B.15 and 3.B.16).

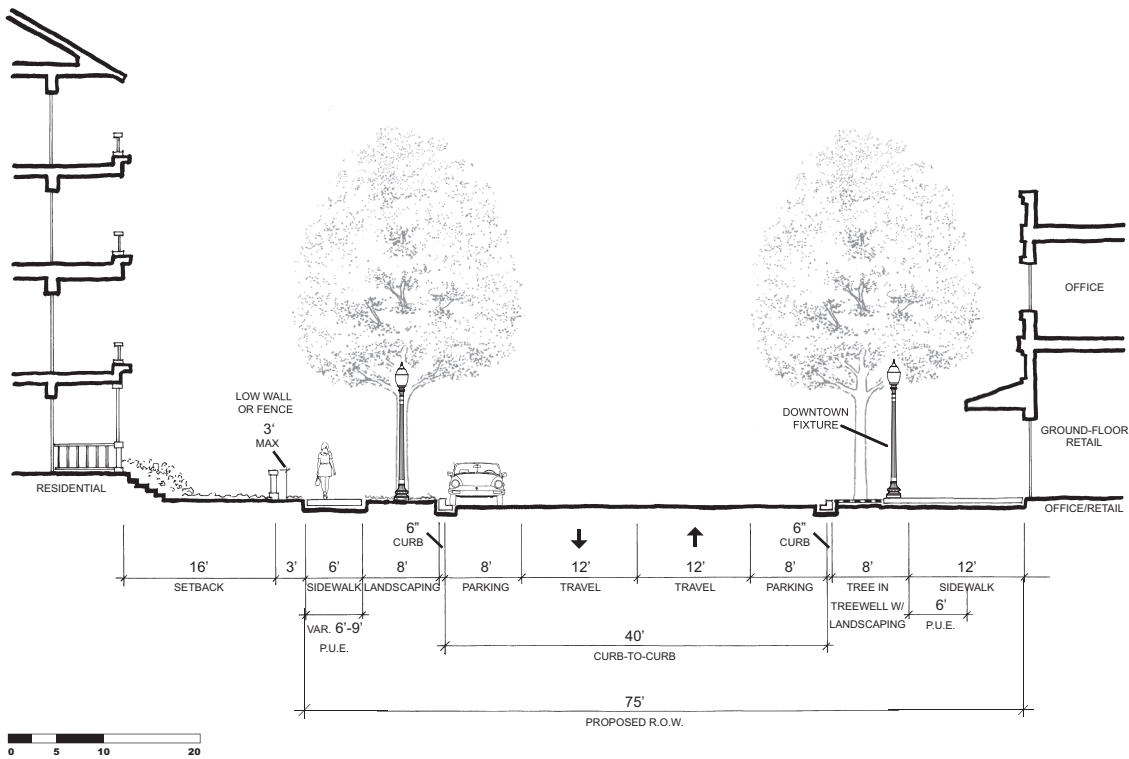

Figure 3.B.15: Section of Marin Street Extension South of Curtola Parkway ①

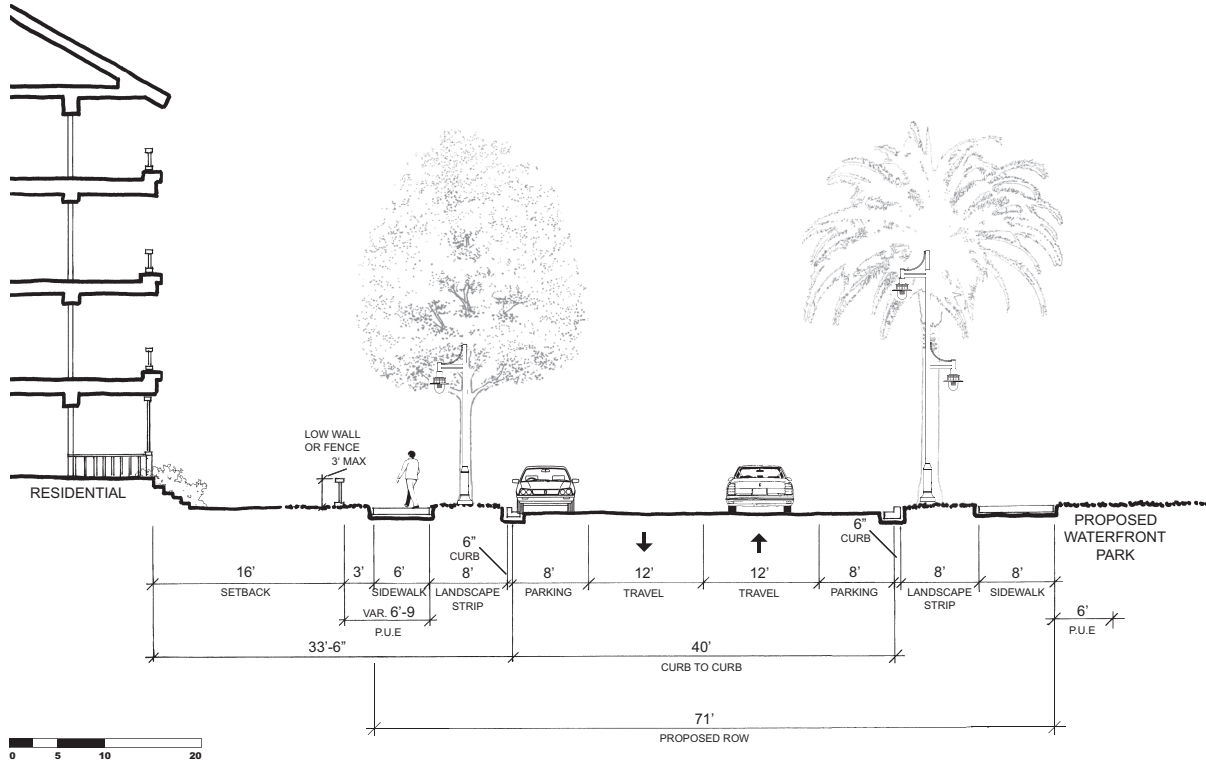

Figure 3.B.16: Section of Marin Street Extension at Residential/Waterfront Park (2)

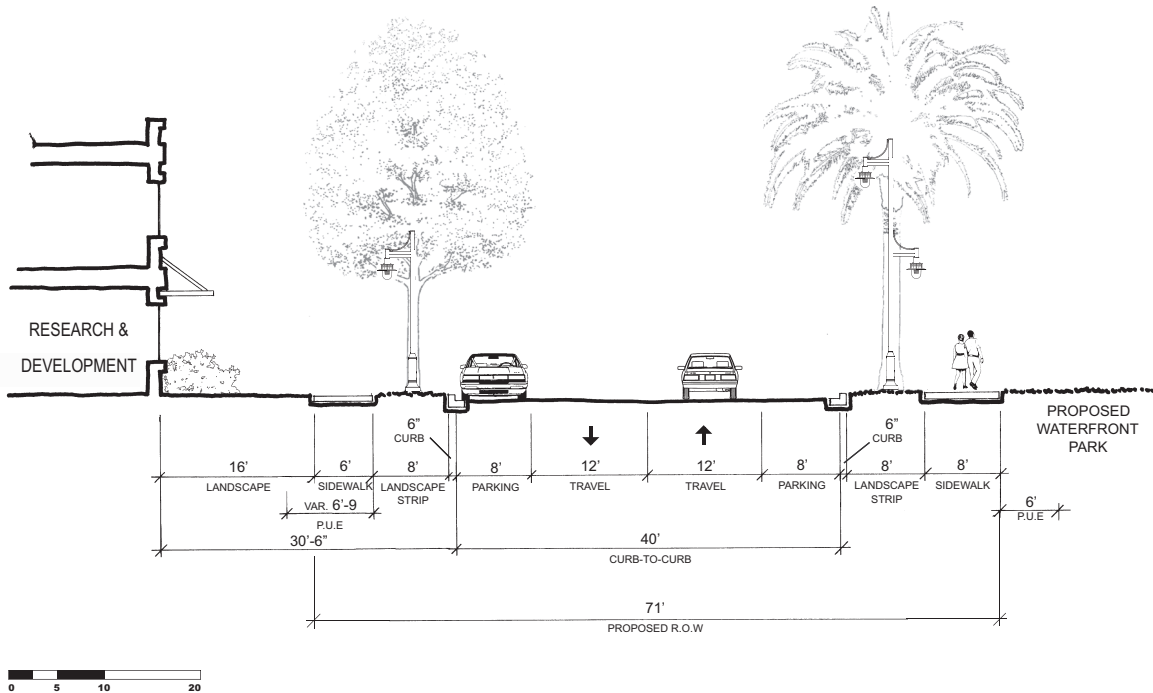

Figure 3.B.17: Section of Marin Street Extension North of Kaiser Place (3)



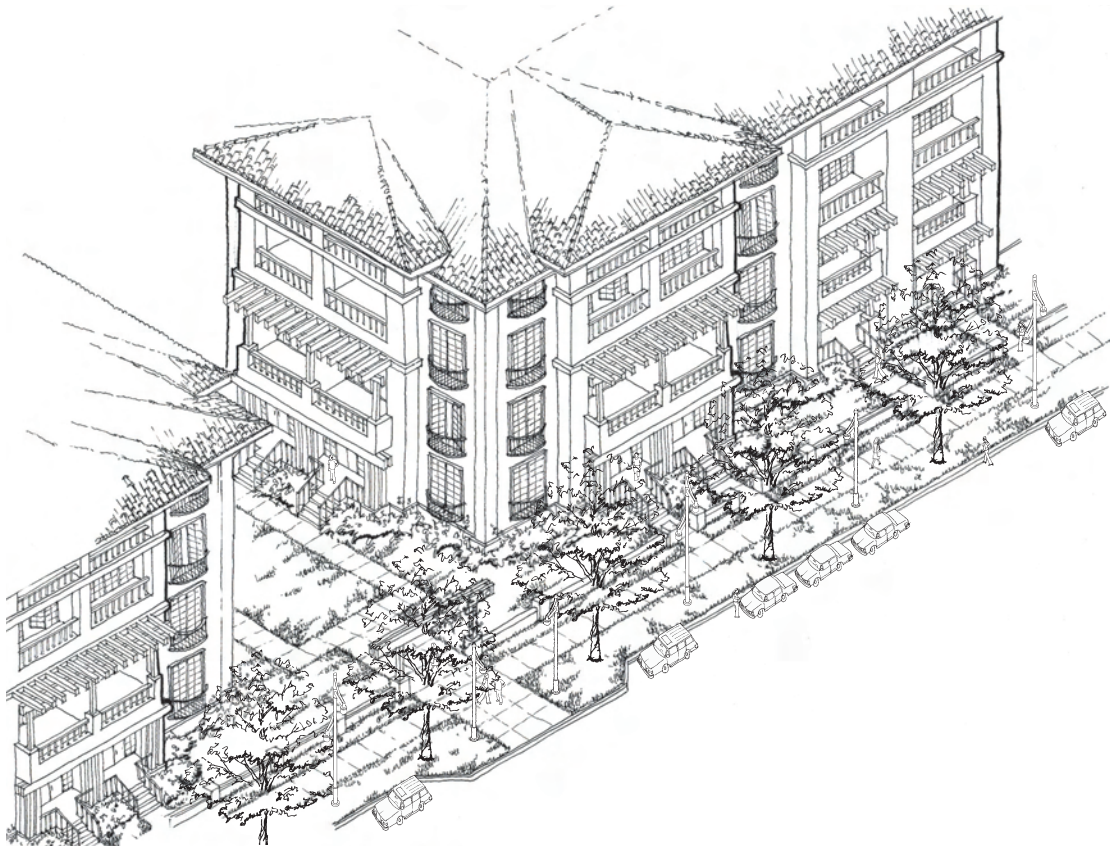

Figure 3.B.18: Concept for Marin Street Extension Streetscape at Residential Block

- Along the proposed mixed-use building at the Curtola Parkway intersection a more urban sidewalk of 20-foot width, including the area for landscaped tree wells, and streetscape is provided to accommodate pedestrians entering and exiting ground-level shops and walking to an from the parking lot behind the building. (Figure 3.B.15);
- Towards the southern end of the Marin Street extension adjacent to the research and development area, the cross section of the street remains consistent with the residential area with an 8-foot wide landscaped strip and 6-foot wide sidewalk. But the building setback is a 16-foot “build-to-line” with the area used for landscaping between the building and sidewalk; this provides for a visual linkage between activity in the building and the street and park. (Figure 3.B.17);
- Along the frontage of future park areas in the Southern Waterfront an 8-foot sidewalk is provided to accommodate pedestrians strolling at the park’s edge. An 8-foot landscape strip provides for street trees and a landscaped buffer between the sidewalk and the street (Figures 3.B.16 and 3.B.17).

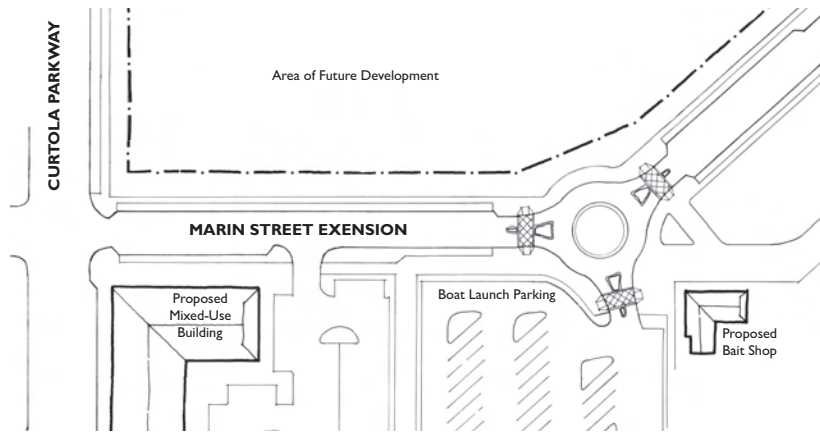

Figure 3.B.19: Roundabout Option at Boat Launch Entry

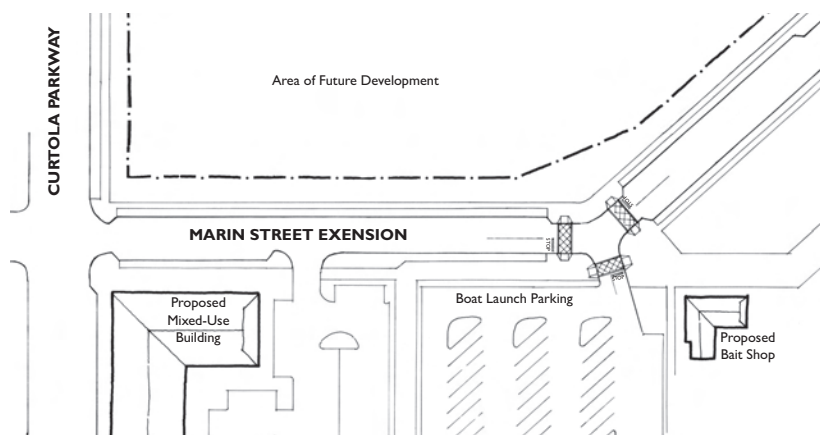

Figure 3.B.20: Three-Way Stop Option at Boat Launch Entry

It is critical to ensure that travel speeds of vehicular traffic along the Marin Street extension remain low (at 25 mph), and that pedestrians can cross the road safely in locations where key connections exist between the residential development on the east side of the street and the Waterfront Park and Promenade on the west side. Therefore, it is highly recommended that a roundabout or a three-way stop intersection be provided where the road bends adjacent to the entry for the boat launch parking lot.

A possible roundabout configuration of the street is illustrated in Figure 3.B.19, which integrates the entry into the boat launch parking lot and provides the opportunity to accommodate a highly visible landscape or public art feature in the center of the circle. The roundabout’s geometrics would be designed to slow traffic to the desired speed level while accommodating all vehicle movements required for this area, including trucks with boat trailers. The pedestrian crossings would include well marked crosswalks and refuges, as per “best practices” recommended by the Federal Highway Administration (FHWA).

As an alternative to the roundabout, a three-way stop signed intersection could be provided as illustrated in Figure 3.B.20. This would also achieve the goals of providing safe pedestrian crossings and slowing vehicular travel speeds. Similar to the roundabout, this configuration also integrates the entry to the boat launch parking. Curb bulb-outs should also be provided to shorten crossing distances and to visually reduce the width of the roadway, a common traffic-calming technique. In comparison to the roundabout option, the three-way intersection does not take up as much space, but provides less opportunity for the inclusion of art work or other design feature as a landmark for the Southern Waterfront District.

### 2.2.1.B Kaiser Place

Kaiser Place is a new street in the Southern Waterfront District that provides access to residential uses along its north side, and to the future U.S. Postal Service facility and the light industrial/research and development area on the south side of the street. The street will also give residents and employees direct access to the Southern Waterfront’s open space.

Similar to the Marin Street extension, Kaiser Place will have a 40-foot wide roadway, with residential buildings set back from the curb by 35 feet (Figure 3.B.22). The street is designed to provide a transition from the residential uses on the north side to the light industrial uses on the south side. Sidewalks on both sides are sized for residential-level use, however a 24-foot wide landscaped berm between the southern sidewalk and adjacent light industrial uses provides a buffer for pedestrians on the street and more of a visual separation between the residential and light industrial uses. Both sidewalks are separated from the street by a tree-lined landscape strip, which enhances the overall residential character.

The light fixtures along Kaiser Place will match the Waterfront theme to reinforce the close connection between the uses along the street and the nearby Waterfront parks.

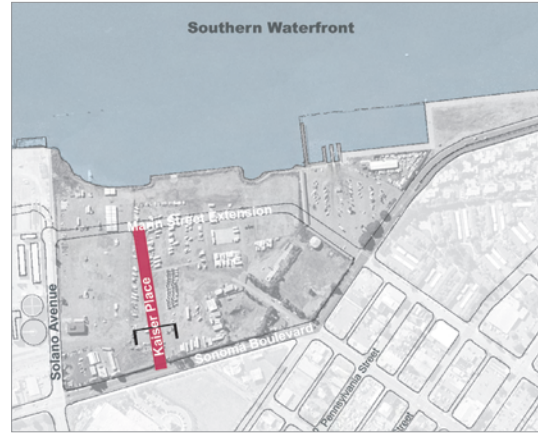

Figure 3.B.21: Kaiser Place and Section Location Diagram

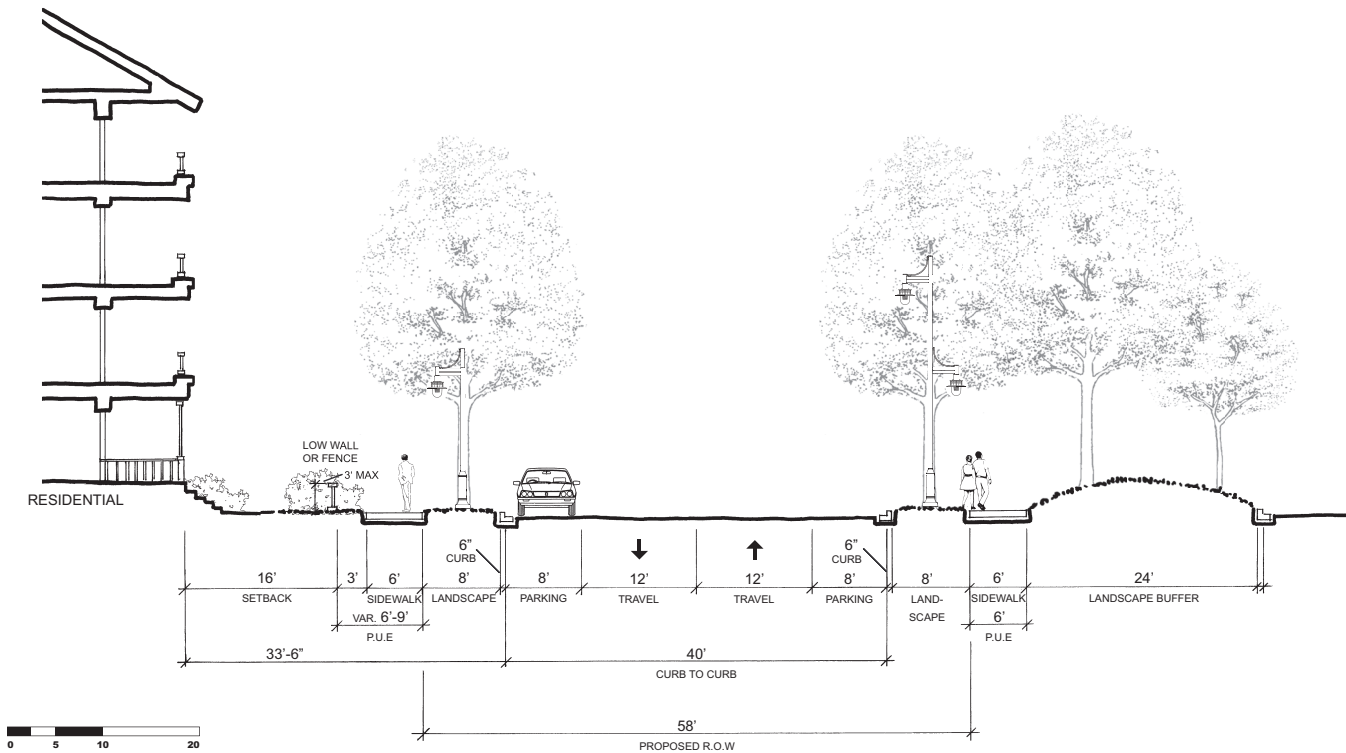

Figure 3.B.22: Kaiser Place Cross Section

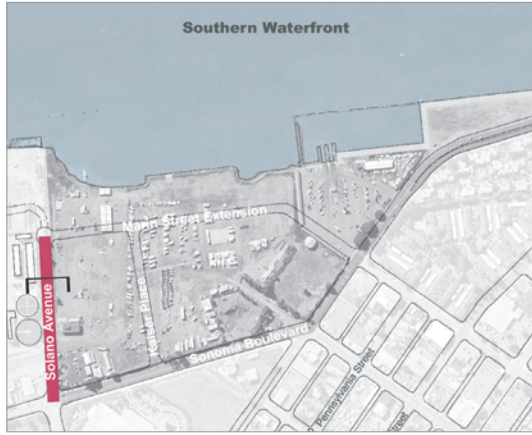

Figure 3.B.23: Solano Avenue and Section Location Diagram

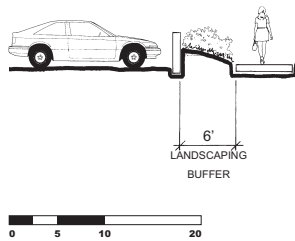

Figure 3.B.24: Landscape Buffer Treatment - Alternative 2

### 2.2.1.C Solano Avenue

The parking lots of the light industrial businesses and the U.S. Postal Service facility front onto Solano Avenue and the existing sewer treatment plant on the far side of the street. Although it is not expected that high volumes of pedestrians will be traveling along this street, there still is a need for a streetscape that appropriately buffers the north side sidewalk from the adjacent parking lots. Additionally, a landscaped buffer on the south side of the street will visually separate the sewer plant from the Southern Waterfront.

Figures 3.B.24 and 3.B.25 illustrate two alternative ways to buffer the sidewalk from the parking lots. Alternative 1 provides a buffer with a wider landscape area, Alternative 2 creates a similar effect by screening parked cars from view behind a berm that terminates in a low wall. While both approaches will be effective, the latter requires less space and may therefore provide more flexibility for pedestrian-friendly improvements internal to the parking lots.

Figure 3.B.25 also illustrates the otherwise compact design of the actual roadway, which provides lane widths sufficient to accommodate the larger vehicles that access the treatment plant as well as on-street parking along the north side of the street. The on-street parking provides a buffer between the sidewalk and the traffic on the street.

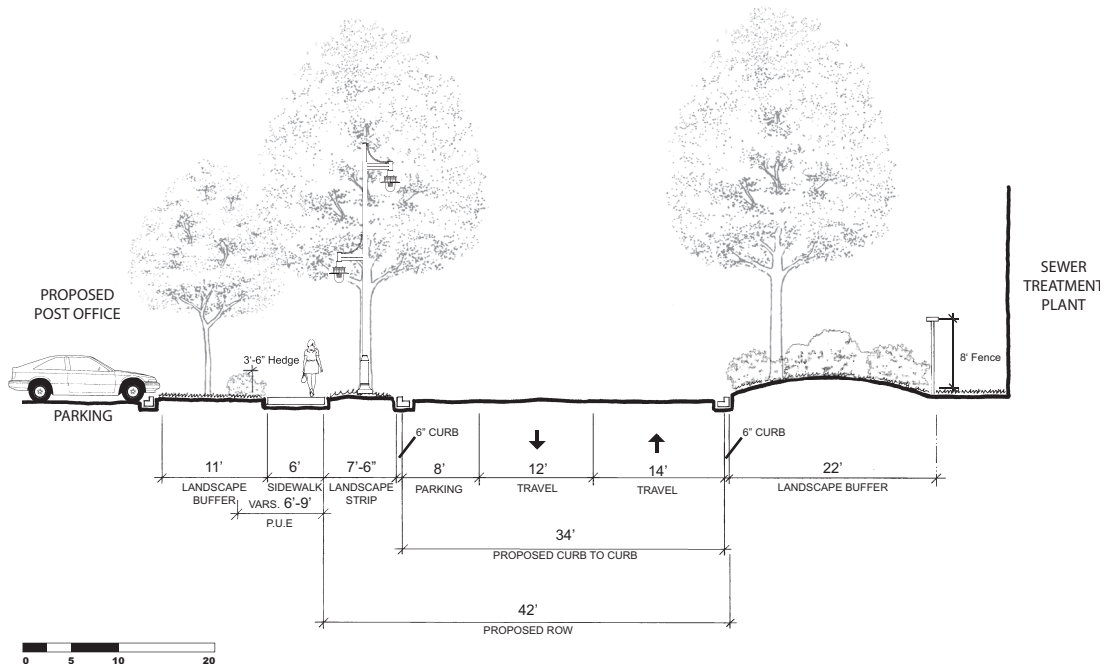

Figure 3.B.25: Solano Avenue Cross Section with Landscape Buffer - Alternative 1



### 2.2.1.D Curtola Parkway

Curtola Parkway constitutes Mare Island Way’s extension to the Sonoma Boulevard intersection, and is therefore an important gateway to the Vallejo Waterfront Districts. The Guidelines propose to modify the southern edge of the street to provide a better walking environment for pedestrians adjacent to the new residential neighborhood and to provide an appropriate edge and buffer between the street and the new homes.

Figure 3.B.27 illustrates the relationship between the roadway and the new residential buildings in the Southern Waterfront, which are set back from the curb edge by a total of 35 feet. Within this landscaped setback, an 8-foot sidewalk is provided that is buffered from the street by a 9-foot 6-inch wide landscape strip. This separation is critical as there is no on-street parking on Curtola Parkway, and therefore a lack of additional buffering of pedestrians from the traffic on the street.

The light fixtures along Curtola Parkway will match those on Mare Island Way to provide a continuation of the Waterfront theme out to the primary entry point to the Waterfront Districts at the Sonoma Boulevard intersection.

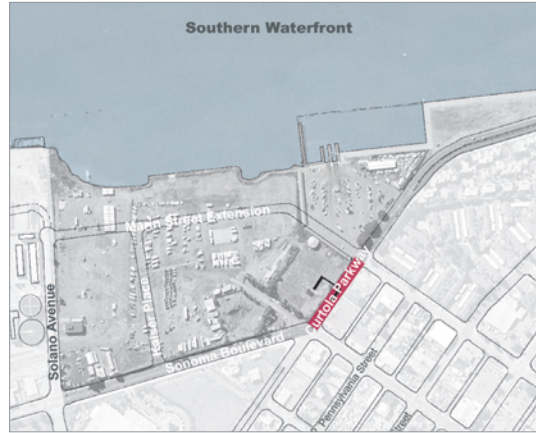

Figure 3.B.26: Curtola Parkway and Section Location Diagram

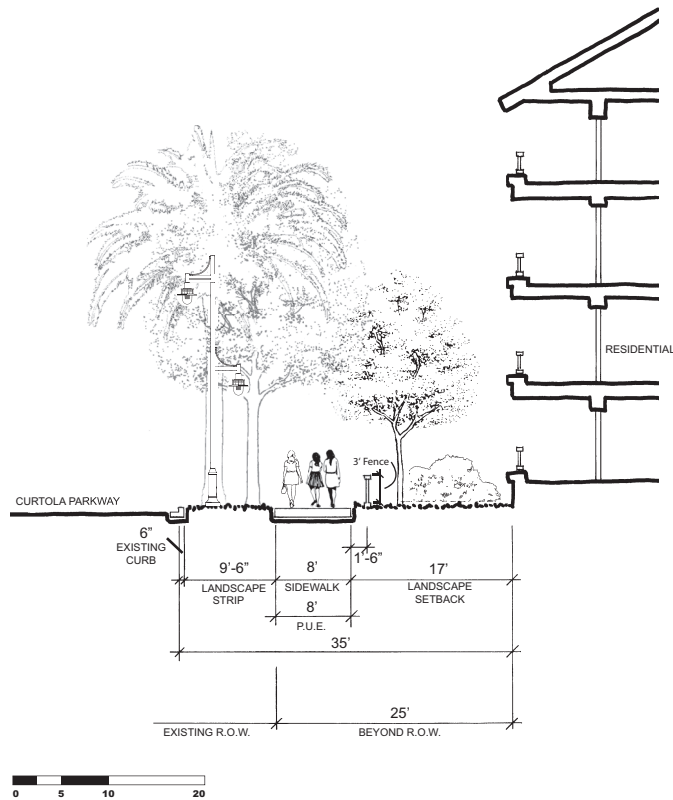
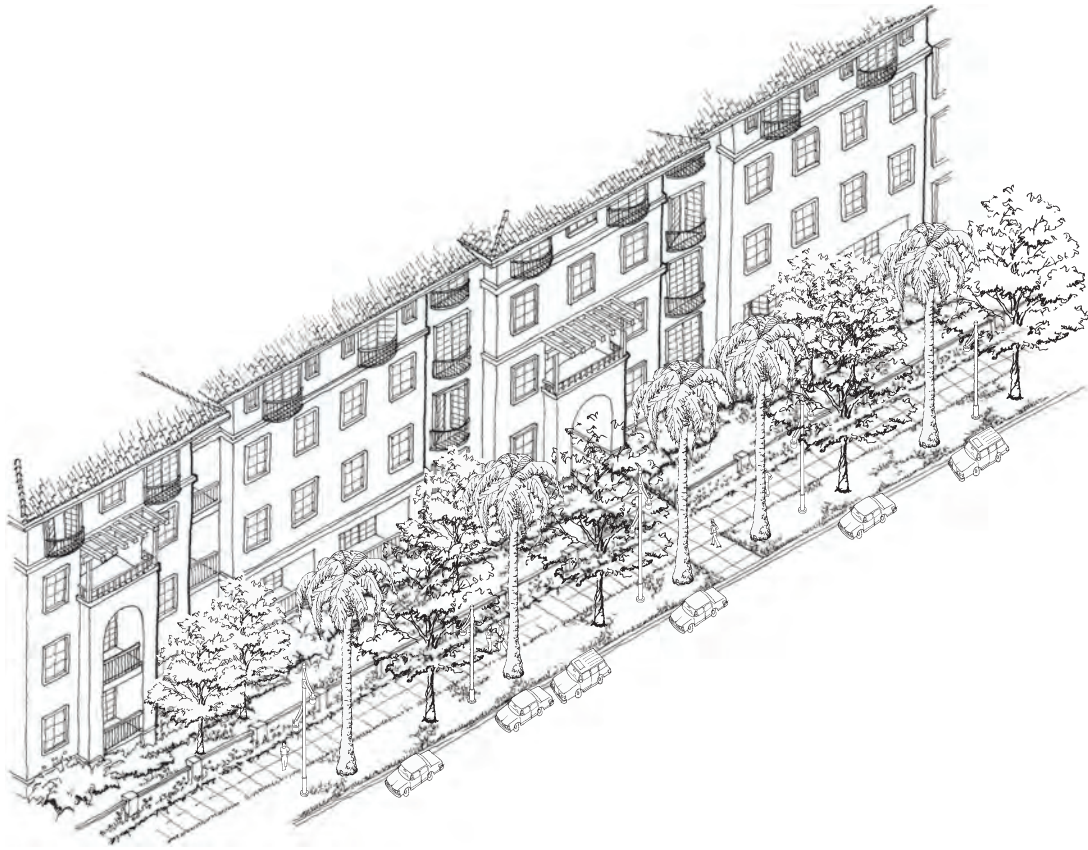

Figure 3.B.27: Curtola Parkway Partial Cross Section





*Figure 3.B.28: Concept for Streetscape For Curtola Parkway*

2.2.1.E Sonoma Boulevard

Sonoma Boulevard is a major artery of traffic in Vallejo that connects the Downtown with significant parts of the City and the region beyond. It is also State Route 29, and is under the jurisdiction of the State Department of Transportation (Caltrans). While these Guidelines do not propose any changes to the roadway cross-section of Sonoma Boulevard, similar to Curtola Parkway, improvements to the area beyond the curb are necessary in order to provide an appropriate walking environment along the west side of this wide and relatively high-speed and highly traveled street.

Figure 3.B.30 illustrates the proposed improvements, which would reconfigure the westernmost 16-foot 6-inches of the existing Sonoma Boulevard right-of-way. Very similar to the improvements described above for Curtola Parkway, the residential buildings will be separated from the roadway by a total of 35 feet, with a sidewalk that is buffered from traffic by a 10-foot tree-lined landscape strip.

The existing cobra-head type light fixtures should be supplemented by pedestrian-scale fixtures of the Downtown theme between the Sonoma Boulevard intersections with Solano Avenue and Curtola Parkway. This is intended to reinforce the sense of arrival for all modes of traffic as travelers approach the Downtown from the south on Sonoma Boulevard.



Figure 3.B.29: Sonoma Boulevard and Section Location Diagram

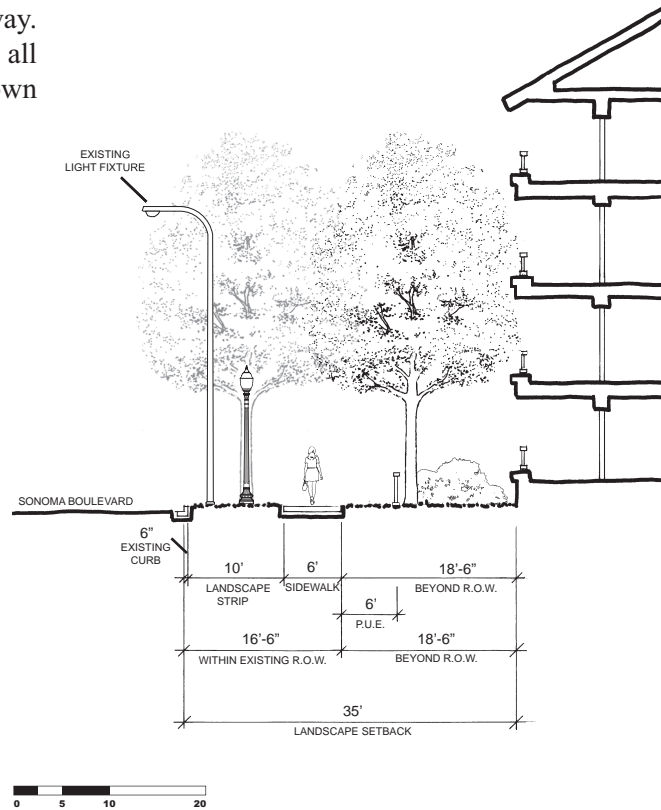

Figure 3.B.30: Sonoma Boulevard Partial Cross Section



Figure 3.B.31: Mare Island Way and Section Location Diagram (For a description of section nos. 1 and 2 see Northern Waterfront Section 2.3.3.B.; For a description of section nos. 3 through 7, see Central Waterfront Section 2.2.1.G.)

2.2.1.F Mare Island Way at Mixed-Use Building North of Marin Street Extension

The Marin Street Extension will provide access to a variety of uses in the Southern Waterfront District, including: housing, industrial, and research and development, as well as a variety of Waterfront open spaces. It is therefore important to provide a recognizable entry where this street intersects with Mare Island Way. The proposed retail/office mixed-use building at the intersection of Mare Island Way and the Marin Street Extension provides the opportunity for establishing a recognizable use in this location with direct relationship to both streets.

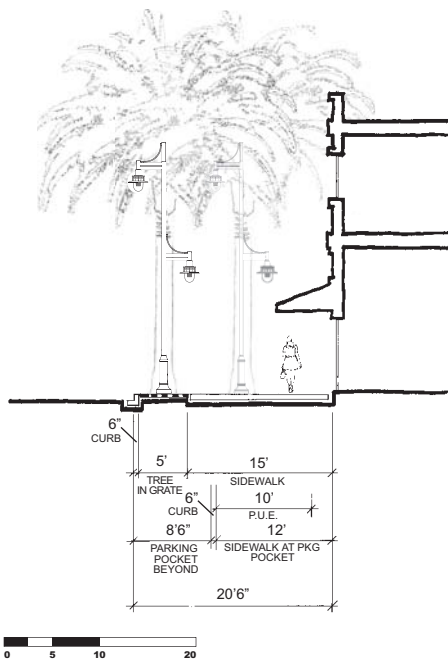

Figure 3.B.32: Partial Section of Mare Island Way at Retail South of Marin Street Extension in Southern Waterfront District (8)

The (on average) 20-foot deep distance from edge of traveled-way to the mixed-use building and Mare Island Way is proposed to be utilized for accommodating on-street retail parking in parking pockets and a sidewalk of urban character, with street trees in tree wells covered by tree grates (see Figure 3.B.32). The character and design of the streetscape elements in this area is the same as the Mare Island Way improvements discussed earlier. This consistent use of design elements serves to tie together the different sections of Mare Island Way.



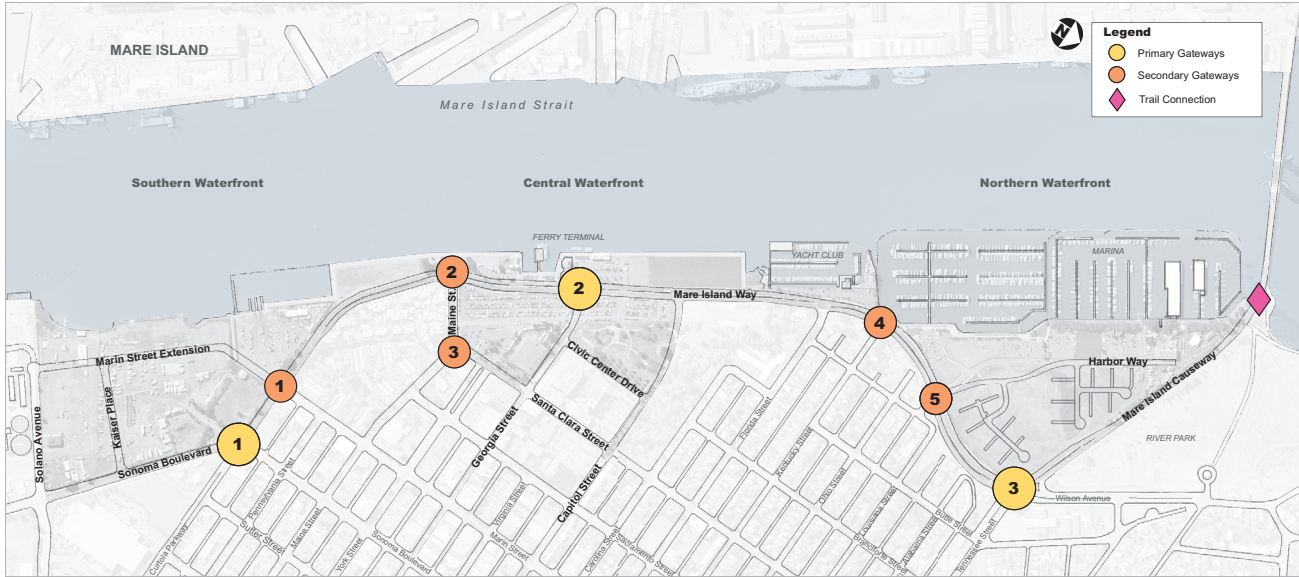

Figure 3.B.33: Diagram of Primary and Secondary Gateways

## 2.3 Gateways

### 2.3.1 Primary Gateway

The primary southern gateway is located at the intersection of Curtola Parkway and Sonoma Boulevard. This gateway has some of the same challenges as the northern gateway given the size of the streets that intersect here and the skewed geometry of the intersection.

This gateway should be highlighted by landmark streetscape or monument features at the southwest and northwest corners of the intersection. These features would frame the entry towards Mare Island Way as one approaches the intersection along north or south bound Sonoma Boulevard or west bound Curtola Parkway. Alternatives for the gateway treatment include:

- Use of street trees to highlight the gateway. Depending upon the street trees that are selected for Mare Island Way, either more closely spaced palms or elms could be planted along the first 40 to 60 feet of the street moving west from the intersection. An additional highlight could be provided by planting flowering plums closer to the intersection.
- Built landmarks could be used to highlight the gateway. These could be either public art pieces or architectural monuments.

### 2.3.2 Secondary Gateway

The secondary gateway in the Southern Waterfront is located at the intersection of Mare Island Way and Marin Street. This intersection will connect the Downtown to the Southern Waterfront residential development and open space through the proposed Marin Street Extension. Use of streetscape, landscaping, or built landmarks is recommended for marking the secondary gateway to the Waterfront.

### 3. Private Realm Guidelines

This section includes District-specific Guidelines that define the particular character of the Southern Waterfront District as a mixed-use residential/commercial area that is distinct from the character of the Central Waterfront. Where uses in the Central Waterfront are more varied and tend to be mixed within blocks, residential and commercial uses in the Southern Waterfront are accommodated in separate buildings and blocks. The exception being the building at the corner of Mare Island Way and the Marin Street extension, which combines ground-floor retail with office uses above.

#### 3.1 Site Design and Building Orientation

The Southern Waterfront District includes a diverse range of buildings and uses. Parking required for residential uses will be accommodated in structured parking underneath the units, while the parking related to retail, office, and other uses will be in surface parking lots. Because of its direct relationship to the surrounding open spaces rather than an orientation towards the public streets in the District, the bait shop building is discussed in *Section III.B 2.1 Waterfront Promenade, Parks, and Open Space Guidelines*.

##### 3.1.1 Relationship of Buildings to Streets and Open Spaces

Similar to development in the Central Waterfront, the residential buildings in the Southern Waterfront will create nearly continuous frontages along adjacent streets with breaks to provide semi-public open spaces and allow for pathways into the development's interior. These openings also provide views into the development's landscaped courtyards.

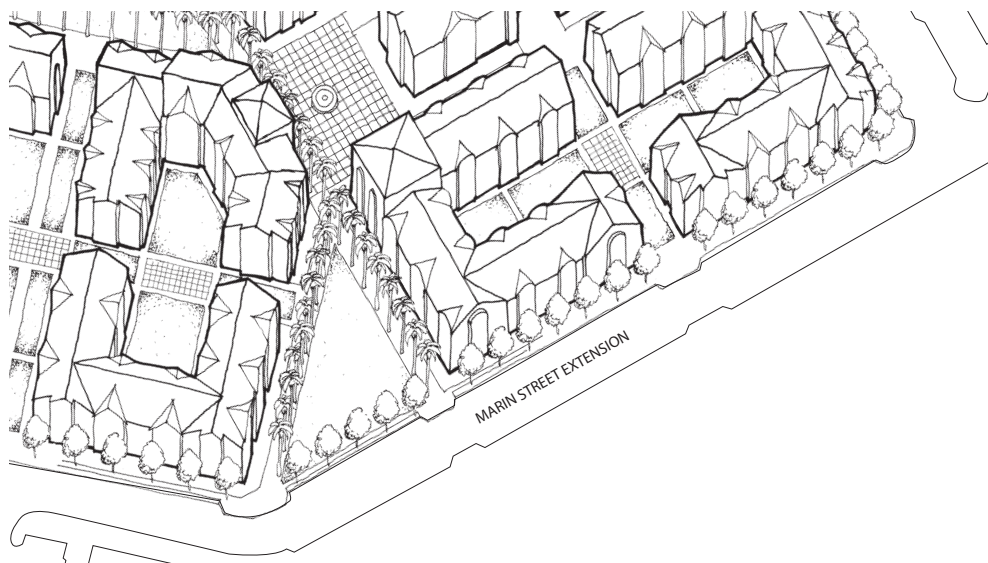

Figure 3.B.34: Diagram of Relationship of Buildings to Public Realm for the Residential Neighborhood



Deeper landscaped areas between buildings and the streets create a less urban character as compared to the proposed Central Waterfront development. The frontages of the Marin Street extension and Kaiser Place will be treated as front yards to create a more direct relationship between residential buildings and the District's public open spaces. Similar to conditions in the Northern Waterfront, it is important to create a mutually enhancing relationship between buildings and landscaped/open spaces. The frontages along Curtola Parkway and Sonoma Boulevard provide a visual separation between the traffic along these streets and the residences and post office within the Southern Waterfront.

The mixed-use building at the corner of Mare Island Way and the Marin Street extension provides an opportunity to extend the character of Downtown to this location. Although only two stories tall, it will create a recognizable landmark that has a more urban relationship to the street.

The research and development/light-industrial building and postal facility between Kaiser Place and Solano Street are seen as a transition to the existing sewer treatment plant and heavier industrial uses located beyond the District's southern end. The Guidelines capitalize on particular contributions that these buildings and their landscaping can make to the public realm.

#### 3.1.1.A Building Setbacks – Residential Buildings

1. Residential buildings should be set back from the back of adjacent sidewalks/the face of curb according to the following table.

Street	Distance from Back of Sidewalk	Distance from Face of Curb
The Marin Street extension and Kaiser Place	19 feet	33.5 feet
Solano Street	18.5 feet	35 feet
Curtola Parkway	17 feet	35 feet

Table 3.B.1: Residential Building Setbacks

### 3.1.1.B *Building Setbacks – Non-residential Buildings*

1. Mixed-Use Building at the corner of Mare Island Way and the Marin Street extension: The Mare Island Way and the Marin Street extension frontages of the mixed-use buildings should be built directly abutting the sidewalk along these two streets. This will emphasize Marin Street’s relationship to the Downtown by anchoring the street corner in the same way a building in the downtown would. In addition, the direct relationship between first floor retail uses and the sidewalk will increase the visibility and connection between activity in the buildings and pedestrian activity on the streets.
  
2. Research and Development/ Light Industrial Buildings: Buildings on the research and development /light industrial site should be set back 16 feet from the back of sidewalk along the Marin Street extension. Locating parking areas between buildings and the sidewalk is strongly discouraged in order to anchor this southernmost block along the Marin Street extension, and to focus human activity onto the street and the Waterfront Park across the street.

Along Kaiser Place, the parking area of the R&D/ light industrial buildings should be separated from the adjacent sidewalk by a 24-foot landscape buffer. An 11-foot landscaped buffer should separate parking area and sidewalk along Solano Street (Also see *Section III.B.3.1.4 Off-Street Parking Areas*).

3. Postal Facility: The setback of the postal facility’s main building should match that of the residential buildings to the north (18.5 feet) to maintain a visually consistent frontage along the street. The setback should be landscaped with ornamental landscaping of a more formal character, reflecting the civic nature of the post office.

Along Kaiser Place, the parking area of the postal facility should be separated from the adjacent sidewalk by a 24-foot landscape buffer. An 11-foot landscaped buffer should separate parking area and sidewalk along Solano Street (Also see *Section III. B.3.1.4 Off-Street Parking Areas*).

### 3.1.1.C *Building Frontage – Residential Buildings*

1. Residential buildings along the Marin Street extension, Kaiser Place, Curtola Parkway, and Sonoma Boulevard should primarily form continuous, uninterrupted frontages of up to a maximum of 250 feet in length.
2. At a minimum, provide a break in the continuous building frontage every 250 feet. The break should be a minimum of 30 feet in width and provide views into and out of landscaped plazas and courtyards internal to the residential development.
3. If continuous frontages beyond 250 feet in length are desired along Curtola Parkway and Sonoma Boulevard, an open passageway should be provided through the first one or two floors of the building at maximum distances of 250 feet. Such passages should receive architectural emphasis through treatment of the building's façade articulation, rooflines treatment, and architectural detailing. The passages should also provide views into and out of the landscaped plazas and courtyards internal to the residential development.
4. Residential buildings should front streets and public and semi-public (located on private property but made accessible to the public) open spaces with porches and stoops to individual unit entries, lobbies to upper-story units, living rooms and dining rooms.

### 3.1.1.D *Building Frontage – Non-residential Buildings*

1. Mixed-Use Building at the corner of Mare Island Way and the Marin Street extension: In order for the building to successfully anchor the corner of Mare Island Way and the Marin Street extension it is critical that the primary façades of the proposed buildings directly relate to both streets with entries, windows, and engaging architectural detailing. Loading and service areas should be on the sides or rear of the building, or remote portions of the rear parking lot.
2. Research and development/Light Industrial Buildings: Office uses and employee amenities, such as cafeterias and recreational facilities, associated with research and development/light industrial uses should be located along the Marin Street extension and Kaiser Place (across from the residential development). This will provide a more immediate relationship between more frequently populated portions of the building and

adjacent open spaces and streets. Entries, windows, and engaging architectural detailing should be utilized to further enhance the façades along the Marin Street extension and Kaiser Place. Loading areas, roll-up doors, and other service areas of the development should be located away from, and visually buffered from, the Marin Street extension and Kaiser Place.

3. **Postal Facility:** The postal facility's main building should directly relate to Sonoma Boulevard and address this street with entries, windows, and a strong architectural presence. This will enhance the street's urban character with a building frontage that reflects the proximity to Downtown Vallejo. Along Sonoma Street and Kaiser Place, the postal facility building may be separated from the street by surface parking areas and buffer landscaping.

### 3.1.2 Building Entries and Access

Locating main entries on the street-facing side of buildings will create a strong relationship between the private realm and the public realm in the Southern Waterfront, with primary retail entrances relating directly to adjacent sidewalks; office, industrial, and post office entries oriented towards small landscaped plazas adjacent to streets; and residential entries of first floor units connecting to sidewalks via entry paths through landscaped front yards.

#### 3.1.2.A Residential Entry Orientation Guidelines

1. First-floor residential units along the Marin Street extension and Kaiser Place should have individual entries that directly relate to these streets.
2. Lobby entries to upper floor units and units within the interior of the development along the Marin Street extension and Kaiser Place should also be oriented toward the street. Where buildings and lobbies are located interior to the residential block, lobby entries should be oriented towards the primary pedestrian circulation system within the block and, whenever possible, be visible from a public street.
3. Along Curtola Parkway and Sonoma Boulevard, any building entries that are provided from these streets should be through lobbies that are directly visible from these streets and accessed from landscaped entry plazas accessible from the public sidewalk.

### 3.1.2.B Non-residential Entry Orientation Guidelines

1. Every non-residential use should have its own entry directly from or connecting to a publicly accessible sidewalk, walkway, or plaza space.
2. Entries to retail spaces, restaurants, and cafes should be recessed to increase the circulation space available to pedestrians who are entering and exiting the business.
3. At secondary building entries oriented towards parking lots, where sidewalk space is limited due to constraints of parking lot layout, recessed entry plazas should be provided to increase circulation space available for people accessing the building.
4. Mixed-Use Building at the corner of Mare Island Way and the Marin Street extension: Primary entries into businesses and offices should directly relate to the adjacent sidewalks on Mare Island Way and the Marin Street extension. Secondary entries may be provided on the parking-lot side of the building.
5. Research and Development /Light Industrial Buildings: The main entries to the R&D/light industrial buildings should be integrated into façades facing the Marin Street extension. This will further the intent to concentrate pedestrian activity along this route through the Southern Waterfront and give primacy to an “address” fronting onto the park (see Figure 3.B.35). Secondary entries may be provided on the parking-lot side of the buildings.
6. Postal Facility: The main pedestrian entry to the postal facility should relate to Sonoma Boulevard to focus pedestrian activity associated with this civic facility onto the street. The entry may be located at the southeast corner of the building to provide access from both Sonoma Boulevard and an adjacent parking lot. Secondary entries may be provided on the parking-lot side of the building.



Figure 3.B.35: R&D/Light Industrial building entries should be designed as gathering places.



### 3.1.2.C Entry Spacing Guidelines – All Buildings

1. Entry spacing for various uses should follow the Guidelines below given for predominant ground-floor use. Entries for upper floor uses may count towards requirement.

Land Use	Maximum Distance (on center)	Minimum Average Distance (on center)
Residential	42 feet	36 feet
Retail	60 feet	40 feet
R&D / Office	120 feet	None

Table 3.B.2: Entry Spacing Guidelines

### 3.1.3 Visibility of Ground Floor Activity in Mixed-use Buildings

Visibility of ground floor activity is particularly important for the mixed-use buildings at the corner of Mare Island Way and the Marin Street extension, and for the research and development/light industrial buildings at the southern end of the District. This will create an engaging pedestrian environment along the Marin Street extension, which is the major pedestrian route in the District, and fronting onto the Southern Waterfront Park.

1. Mixed-Use Building at the corner of Mare Island Way and the Marin Street extension: Clear windows should dominate the façades along all street frontages of the mixed-use building to provide a direct visual connection with interior activities in retail establishments and cafés.
2. Research and Development/ Light Industrial Buildings: Office uses and employee amenities, such as cafeterias and recreational facilities, associated with research and development/light industrial uses should be located along the Marin Street extension and Kaiser Place to allow for some views of activities in these buildings. Clear windows should dominate the façade along the Marin Street extension.

### 3.1.4 Off-Street Parking Areas

Parking for non-residential uses in the Southern Waterfront District will occur in surface parking lots, while residential parking will be accommodated in parking structures underneath the residential buildings and internal open spaces. It is critical to achieving the desired District character that all surface parking lots are well buffered from residential uses and pedestrian routes of adjacent streets and open spaces. As most visitors to non-residential buildings in the area will arrive in one of the parking lots, it is important to provide high quality pedestrian circulation within the parking areas surrounding buildings. Finally, because of their large paved areas, surface parking lots can negatively impact the microclimate in their surroundings and create large amounts of stormwater run-off unless care is taken in their design. The following Guidelines, which supplement those in *Section III.A.2.2.5 Off-Street Parking and Drop-off Areas*, address how this can be achieved. Also see *Section III.A.2.2.1 Green Site and Building Design*.

#### 3.1.4.A Surface Parking Design – General Guidelines

Parking screening and landscaping is required to both provide a spatial and visual buffer for pedestrians walking adjacent to surface parking areas and to provide an area that helps to counter-balance the negative impacts of large impermeable surfaces.

1. Where surface lots abut sidewalks and pedestrian routes, parking screening and landscaping is required to provide a buffer for pedestrians walking along adjacent streets, protect pedestrians from car headlights in the evening, and to provide a shaded and comfortable microclimate. Buffers also reduce the sense of auto-orientation and communicate that the Southern Waterfront affords priority to pedestrian access.
2. Buffers should include a combination of trees, shrubs, vines, low walls, berms, or landscape structures that create a visual and physical separation as well as an attractive frontage onto sidewalks, parks, and other adjacent areas.
3. The landscape buffer should be a minimum of 6 feet wide if a hedge is used and 8 feet wide if trees and shrubs are used. Where widths are constrained less

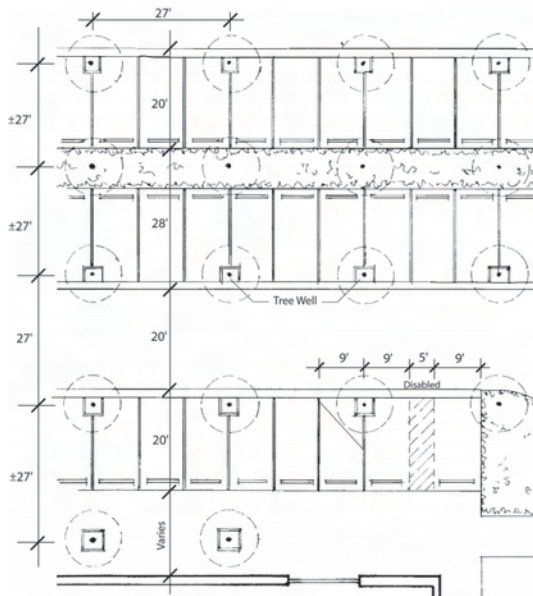

Figure 3.B.36: A parking “orchard” with regularly spaced trees provides even distribution of shade.

than 5 feet , a low wall may be used in place of shrubs and hedges. Greater separation and articulation may be achieved with a visually permeable landscape structure such as a trellis (See also *Section III.B.3.1.4.B Surface Parking- Location-specific Guidelines* in the next subsection for buffer widths and treatments along Kaiser Place and Solano Street).

4. Shrubs, hedges, and low walls should not be more than 3 feet tall. Landscape structures should be no more than 6 feet tall.
5. If a low wall is used, vines or other landscaping should be used to soften the appearance of the wall from the street.
6. Buffers should be protected from car fenders with wheel stops or a 6 inch curb. If a 6 inch curb is used, low ground covers should be located within the area 18 inches from the face of curb.
7. Parking lots greater than 24 stalls (approximately one quarter acre) should provide a tree canopy that will cover 50% of the lot at the time of the trees’ maturity (approximately 10 years). Spacing of trees will depend upon the species and their growing habits. To effectively achieve this coverage, trees should be planted “orchard style” (i.e., evenly spaced throughout the parking lot; See Figure 3.B.36).
8. Additional landscaping within the interior of parking lots should comprise a minimum of 15% of the total net parking area, exclusive of the perimeter planting strip used for screening purposes.
9. Landscape elements such as trees, plants and structures within a parking lot and along pedestrian pathways, should be utilized to reduce the perceived size of the lot and create a more pleasant microclimate for pedestrians.
10. Walkways running parallel to the parking rows (perpendicular to parked cars) should be provided for every four rows, and walkways running perpendicular to the parking rows (parallel to parked areas) should be no further than 20 parking stalls apart. Walkways should also be provided at the edges of parking lots and buildings.

11. The number of driveways into surface parking lots should be minimized. Driveway widths should not exceed 20 feet and should be designed to create minimum interference with pedestrian traffic flows.
12. The Marin Street extension: Limit the number of driveways into parking lots off the Marin Street extension to one per lot.
13. Kaiser Place and Solano Street: Surface parking lots along these streets may have up to two driveways per lot.
14. Driveways should be located away from pedestrian crosswalks, residential lobbies, and primary entries into retail and R&D buildings.

### 3.1.4.B Surface Parking – Location-specific Guidelines

1. Waterfront Promenade at Parking Lots: Where the Waterfront Promenade is located between or adjacent to parking areas for the Mixed-Use Building and the Boat Launch, 10-foot minimum width landscape buffers should be provided. These buffers should include single rows of small-scale trees and taller shrubs .
2. Boat Launch Parking Lot: It is recommended to incorporate the single entry into the boat launch parking lot into either a roundabout or three-way stop intersection (Also see *Section III.B.2.2.1.A The Marin Street Extension*).
3. Research and Development Buildings/Light Industrial and Postal Facility:

*Along Kaiser Place:* Provide a 24-foot wide landscaped and bermed buffer between the southern sidewalk of Kaiser Place and adjacent parking areas.

*Along Solano Avenue – Alternative 1:* Provide an 11-foot landscaped buffer between the northern sidewalk of Solano Avenue and adjacent parking areas that includes a 3.5-foot tall hedge (see Figure 3.B.37).

*Along Solano Avenue – Alternative 2:* Provide a 6-foot bermed landscaped buffer between the northern sidewalk of Solano Avenue and adjacent parking areas that includes a low wall along the head of the parking stalls.

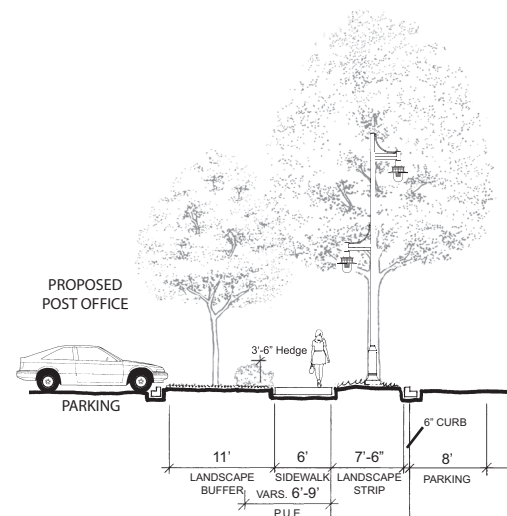

Figure 3.B.37: Buffer sidewalk from surface parking along Solano Avenue



*Figure 3.B.38: Units and porches can step down to grade to hide the parking podium behind*



*Figure 3.B.39: Alternatively, porches, stoops, and stairs can screen the parking podium*

### 3.1.4.C Parking Structures

It is anticipated that the parking structures for the residential development in the Southern Waterfront will be fully underground. However, adverse soil conditions or a high water table may require portions of a parking structure to be exposed above ground level. The following Guidelines will help to create a high-quality and pedestrian-friendly environment in locations where exposed portions of parking structures may be visible from the public realm.

1. If it is necessary to construct podium parking or parking garages under residential units that partially rise above the ground plane, the building frontage along the Marin Street extension and Kaiser Place should:
  - a. Include units that line the edge of the internal podium parking and conceal it from view of passersby on adjacent streets and landscape areas (see Figure 3.B.38). In addition, the units should front streets and landscape areas with porches raised from the ground plane by a few steps; or,
  - b. Provide porches and stoops that access individual residential entries located on the floor above the partially exposed parking structure. The combination of the porches, stoops, stairs, and landscaping should conceal the face of the garage structure from view (see Figure 3.B.39).
2. The number of driveways into structured and underground parking should be minimized. Driveway widths should not exceed 20 feet and should be designed to create minimum interference with pedestrian traffic flows.
3. The width of entry openings into structured and underground parking should not exceed 20 feet. Entries should be incorporated into the building façade design by setting them back within and integrating them with the articulation of the façade.
4. Avoid locating entries to structured and underground parking in portions of a façade that terminate views from pathways and other significant view corridors.



### 3.1.5 Off-Street Loading and Service Access

It is important that off-street loading and service areas are well sited in order to screen these areas from surrounding uses, particularly in locations where side and rear building façades are exposed to adjacent active areas. In addition to the Guidelines outlined in *Section III.A.2.2.6 Off-Street Loading and Service Access*, the following Guidelines are applicable in the Southern Waterfront District.

1. Appropriate screening strategies include evergreen shrubs and trees, vine-covered walls or fences, and trellises.
2. Planting and overhead features such as trellises and arbors should accompany hardscape features such as curbs and low walls which are used to define the boundary between loading and off-street parking circulation.
3. Mixed-Use Building at the corner of Mare Island Way and the Marin Street extension: Loading and service areas should be consolidated and located facing the parking lot at the rear of the building.
4. Research and Development Buildings: Loading and service areas should be consolidated and located along the eastern building façade, where they will face the postal facility. If well screened, service areas may also be located on the south side of the buildings towards Solano Avenue.
5. Postal Facility: Loading and service areas should be consolidated and located in the building's western façade, where they will face the R&D buildings. If well screened, service areas may also be located on the south side of the buildings towards Solano Avenue.
6. Residential Buildings: Building elements, such as garbage receptacles, utility meters, and mechanical equipment should be accommodated within the building envelope to the extent possible. If such elements must be outside of the building envelope, they should be screened from the view of pedestrians. Such screening should occur in ways harmonious with the overall building design.



Figure 3.B.40: Human-scaled Form and Articulation of Two Story Mixed-Use Building

## 3.2 Human Scale and Building Contribution to the Public Realm

Massing, scale, and form of buildings in the Southern Waterfront are mostly critical with respect to the future residential buildings throughout the District and the mixed-use building at the corner of Mare Island Way and the Marin Street extension. The research and development/light industrial buildings should be scaled to fit well within the surrounding context of public open spaces.

Residential buildings within the Southern Waterfront and their massing, height, proportions, fenestration, and other architectural features will combine to create a new, primarily residential District that capitalizes on and directly relates to the excellent views and high-quality open spaces in the area, and provides a human-scaled environment for the District’s residents, workers, and visitors.

The mixed-use building should be similar in quality of design and detail to that found in the architecturally significant buildings of Downtown Vallejo to convey the buildings’ proximity to the Downtown retail area and to help define the intersection of the Marin Street extension and Mare Island Way as a gateway to the Waterfront and the Downtown to the north.

### 3.2.1 Building Form

The Southern Waterfront District is currently a largely vacant area with the exception of a few ancillary buildings sited throughout. The building form for future residential and non-residential buildings should therefore be guided by the assets of the site, such as the exceptional views across the Mare Island Strait, the close relationship to future Waterfront opens spaces, the proximity of portions of the District to the Downtown, and by high quality examples of similar types of development throughout the Bay Area.

#### 3.2.1.A Scale of Building Massing and Height Guidelines

As per the PDMP height standards for the area, residential buildings may be up to 55 feet high and commercial buildings up to 45 feet. It is recommended that the Mixed-use building at the corner of Mare Island Way and the Marin Street extension take advantage of this height limit to provide a corner element that will anchor this important site. The massing of residential buildings should maximize views of the Mare Island Strait and form a network of internal open spaces and pathways that allow visual connections to public open spaces along the Waterfront and into adjacent streets.

1. The massing of buildings should reflect and make visible the use and activity within the building. For example, the use of bays should reflect an interior change of use or function such as a dining room or a private office.
2. Buildings should avoid an overly horizontal look. Where the overall massing of buildings is horizontal,

elements of building form (e.g., bay windows, stairs, elevators, and major entrances) and architectural detail should provide vertical articulation. See also *Section III.A.2.3.1.B Façade Scale and Variation: Façade Articulation and Wall Frontage* for blank wall Guidelines.

3. Building massing and articulation should respond to the views and surrounding context of the District by stepping and varying heights of the residential buildings. Building heights (number of stories) should be relatively higher along Curtola Parkway and Sonoma Boulevard as compared to the Marin Street extension. These changes in massing create a transition in scale as people move from Sonoma Boulevard through the Waterfront along Mare Island Way, as well as opportunities to maximize views from within the residential development towards the Mare Island Strait and Mare Island beyond.
4. Mixed-Use Building at the corner of Mare Island Way and the Marin Street extension: This building should create a well-defined corner statement providing a visual landmark. For this reason, it is strongly encouraged to define the corner with a taller building element that meets the height limit of 45 feet for commercial buildings, set by the Planned Development Master Plan (PDMP).
5. The building's street frontage on Mare Island Way should be designed as multiple façades to relate to the scale of similar retail buildings in the Downtown and to reflect changes in interior usage. For example, the profile of the façade should correspond with changes in ground-level storefronts of the building.
6. Research and Development Buildings/Light Industrial: the height limit of 45 feet established in the PDMP would allow for office uses that are part of the R&D buildings to be up to 3-stories fronting onto the



Figure 3.B.41: Massing and Articulation Diagram for Residential Neighborhood

Marin Street extension. This would allow for views from the office spaces towards the Mare Island Strait and define a stronger edge to the Southern Waterfront Park.

### 3.2.1.B Façade Scale and Variation Guidelines

#### Floor-to-Ceiling Heights

1. Mixed-Use Building at the corner of Mare Island Way and the Marin Street extension: Ceiling heights for ground-floor commercial spaces should be similar to those proposed for the downtown area, which is 16 feet. This is important as downtown development in the future may extend to Mare Island Way, along the east side of the street (See II.A.2.3.1.B Façade Scale and Variation Guidelines for minimum floor-to-ceiling requirements per land use).

#### Variations In Building Façade

The larger-scale massing of the residential buildings within the Southern Waterfront requires more refinement in terms of the human-scale of the buildings through the use of variations in façade elements, such as bays, recesses, overhanging eaves, corner elements etc. that provide interest and scale to the façades of the buildings.

1. Buildings with frontages greater than 30 feet should make use of bays, recesses, overhangs, and other façade elements to create a human-scaled character to the building. The use of changes in plane as small as 6 to 18 inches in depth can be used in combination with architectural detailing, materials, and color to satisfy this Guideline (See Figure 3.B.42).



Figure 3.B.42: Use of Bays, Decks, and Trellises to Create Façade Variation and a Human-Scale



Figure 3.B.43: Building that Anchors a Corner Location

#### Corners and Landmark Features

The mixed-use building at the corner of Mare Island Way and the Marin Street extension should anchor the intersection of these two streets and serve as a landmark at this gateway to the Southern Waterfront District (Also see Figure 1.B.1. Waterfront Framework Plan).

1. Use scale and façade articulation to provide a corner element that enhances the design of this building as landmark that gives emphasis to the intersection of



Mare Island Way and the Marin Street extension (See Figure 2.D.1: Diagram of Primary and Secondary Gateways in *Chapter II: Unifying Elements and Linkages*).

2. Provide an architectural “companion” gateway feature, such as a well articulated tower element, as part of the residential building on the other side of the Marin Street extension.

### Rooflines

1. **Residential Buildings:** The rooflines of residential buildings in the Southern Waterfront should be coordinated with the building’s overall massing. Rooflines should be designed to give emphasis to corner elements, pathways that lead through buildings into the interior of the development, and major changes in façade plane. Secondary roof elements may be used for smaller scale building elements such as porches and bays. However, these may not have a “tacked-on” appearance and need to be integrated into the overall design of the building (See Figures 3.B.44 and 3.B.45 for good and bad examples).
2. **Residential and Research and Development Buildings:** Rooflines and variations in roof orientation should be integrated into the building façade articulation to break down the scale of longer building frontages.

### 3.2.2 Building Articulation

All façades with high visibility from key pedestrian routes, such as the Waterfront Promenade and open spaces, as well as streets with predominantly residential frontages, should provide a level of architectural detailing that responds to a human scale in order to create an environment that will be attractive, interesting, and inviting (For additional Guidelines applicable to all buildings see *Section III. A.2.3.2 Building Articulation*).

#### 3.2.2.A Architectural Detailing – Scale and Ornamentation

#### Building Materials and Finishes

1. **Mixed-Use Building at the corner of Mare Island Way and the Marin Street extension:** A variety of building finishes and materials is desirable in order to create a pedestrian-supportive architecture, and



Figure 3.B.44: Poor Example of Rooflines - Not Enough Relief or Variation



Figure 3.B.45: Good Example of Rooflines - Eaves Create Shadow Line and Form that Relates to Interior Use



to reflect what is used in the Downtown. Acceptable façade materials include: tile (ceramic or clay), masonry (stone or brick), stucco and stone cladding. Acceptable materials for architectural details include: pre-cast concrete and wood.

Other materials that are acceptable, but which should be limited in their use include: higher quality curtain-wall systems that provide shadow lines and scale through the use of mullions that contain relief, metal panels, and synthetic details finished in stucco or concrete masonry units of varied colors.

Acceptable roof materials for visible, sloped roof areas include any high-quality material such as: slate, concrete or ceramic tile and standing-seam metal.

2. Residential Buildings: Porches and stoops of residential buildings should include railings, columns, trellises and other building elements of high-quality craftsmanship and materials. Materials, design details and patterns used for these building elements should vary along a building's frontage to avoid visual monotony and provide a sense of uniqueness. Acceptable materials for porches and stoops include painted wood, natural stone, stucco, terrazzo and brick. Acceptable materials for railings and other detail elements include painted wood, glass and glass blocks, wrought iron, brass and other high quality metals.
3. Research and Development Buildings/Light Industrial: It is strongly encouraged that the façades of research and development/light industrial buildings include variations in building materials to provide the required level of façade articulation and visual interest. This is particularly important for frontages along the Marin Street extension and Kaiser Place. Acceptable materials include high quality concrete, split-faced concrete block, corrugated metal siding, and brick.

### **3.2.3 Transition from Public Realm to Interior Space**

It is envisioned that the 16-foot deep landscaped front yards along the residential building frontage of the Marin Street extension and Kaiser Place, and the recommended use of stoops and porches, will create a gradual and pleasant transition from the public realm of the streets and Waterfront to the private interior of the residential buildings. This will be enhanced by the incorporation of semi-public landscaped pathways and open spaces that reach into the residential development.

1. Residential Buildings along the Marin Street extension and Kaiser Place should front onto streets, public and semi-public open spaces with lobbies, porches and/or stoops to provide a semi-private, transitional space between the public and private realms.
2. The landscaping of semi-public open spaces at the edge and the pathways into the residential development should be designed to create a transitional space, along which, the level of privacy increases with distance from the adjacent street and public open space.
3. Ground floor lobbies to upper floor residential units and research and development buildings should include a significant transparent glass element and directly face public sidewalks, pedestrian routes through interior courtyards, and landscaped plazas. This provides a transition between the public and private realms and makes entrances easy to find. Meandering walkways to lobbies and entries should be avoided.

### 3.2.4 Fences and Low Walls

Fences and low walls along the public sidewalks of the Marin Street extension, Kaiser Place, Curtola Parkway, and Sonoma Boulevard help in defining the edge of the residential development in the Southern Waterfront. Fences and low walls, if carefully designed, provide another opportunity for adding interest to the pedestrian environment.

1. Any solid portion of fences and low walls should be no taller than 3 feet above the adjacent sidewalk.
2. The Marin Street Extension: Fences and low walls along the Marin Street extension should be of a higher level of design than those located along Sonoma Boulevard and Curtola Parkway, where significantly less pedestrian traffic is expected, and are encouraged to include lighting, trellises, and/or landscaping to create an attractive pedestrian corridor along this street.

### 3.2.5 Utilities and Mechanical Equipment

Rooftop utilities on residential and research and development/light industrial buildings in the Southern Waterfront District will be visible from the upper floor of some of the residential buildings and should therefore be screened from view.

1. Carefully screen rooftop utilities from view on Mare Island Way and from elevated residential areas located toward the east. Carefully integrate such screens into the overall architecture of the building and roof design.

This Page Intentionally Left Blank

## C. Central Waterfront District

Guidelines for the Central Waterfront include guidance for the design and implementation of site plans, architecture, landscaping, streetscapes, open spaces, and parking. This section defines the more urban character of this District and its close relationship to Downtown Vallejo. The Guidelines for the Central Waterfront complement the *Downtown Vallejo Design Guidelines* and the intent of the *Downtown Vallejo Specific Plan*.

### 1. District Character and Context

The location of the Central Waterfront grants it great significance to the City of Vallejo. Not only does it act as a gateway to the city for ferry and bus passengers, but also has the potential of associating Vallejo's Downtown intrinsically with the Waterfront. The established character of Downtown Vallejo must have a natural transition to the Waterfront and vice versa.

The Central Waterfront will be the most active and dynamic of the three Districts because of this relationship. It also contains the most active civic spaces of the three Districts including Dr. Martin Luther King, Jr. Unity Plaza, the Festival Green, the Ferry Plaza and building, the grassy area improved by the Service Club Area, Independence Park, the large open space south of Independence Park, and the Bus Transfer Center. It is also in close proximity to the Public Library and City Hall.

The District's parks and open spaces need to accommodate a great variety of activities and programmed events from strolling and people-watching to concerts and markets. Its large open spaces will provide Vallejo with a place to hold city-wide festivals celebrating art, food, culture, and other sponsored activities. There should also be places that provide intimate settings for smaller groups and individuals to relax and contemplate. Spaces should allow people to sit and have intimate conversations, read a book, and be protected from the sun and the elements.

To continue the character of the Downtown to the Waterfront, buildings should be more mixed in their uses and more urban in their character. Much like the Downtown, the ground floor of buildings will need to allow a higher level of interaction between the public and private realm. Buildings within the Central Waterfront District have the added burden of moderating between



Figure 3.C.1: Central Waterfront District Location

the mid-rise buildings (up to 7 stories) specified for the Downtown in the *Downtown Specific Plan* and creating a well-defined and distinct building façade along the Waterfront, while at the same time, not overwhelming existing lower density residential uses surrounding and directly adjacent to the District. Finally, the specific role of the buildings in Vallejo Station in defining this important gateway into the city will require an architecture that is distinct and creates a positive impression.

In addition, Mare Island Way currently bisects the Downtown-side where development will occur from the Waterfront Parks, open spaces and the Ferry Terminal. Mare Island Way is a prominent feature that needs special attention to avoid creating a barrier, and filtering activity across the street shall be encouraged. It is here that the design needs to consider the pedestrian as equal to all other modes of travel, if not primary. Pedestrians should feel as safe and as comfortable walking to and from both sides of Mare Island Way as they would within the Downtown and its streets.

## 2. Public Realm Guidelines

The public realm within the Central Waterfront will be the most actively used portion of the Vallejo’s Waterfront. These areas will see a high level of pedestrian, recreational, and business activity. The program for the open spaces will require a greater degree of structure in order to address and balance the varying needs and desires of visitors. This area will support a dynamic and wide-ranging set of activities that include spillover activities from the Downtown (e.g., farmers markets, festivals, concerts), the ferry operations (e.g., orientation and wayfinding, meetings, informal performances, food and beverage), and the residential-related uses (e.g., jogging, dog walking, bicycling, picnicking, strolling). For these reasons, the Central Waterfront open spaces will include a variety of both formal and informal spaces to accommodate these needs.

### 2.1 Waterfront Promenade, Parks, and Open Space Guidelines

The City of Vallejo is just beginning a public process to review the programming and design of the Waterfront parks and open spaces. The following discussion and Guidelines are intended as a suggested starting point for that process. The concepts, in general, have a relationship to the *Vallejo Waterfront/Downtown Master Plan for Public Spaces*, and the City’s new process will provide the opportunity to consider both the suggestions of the previous Master Plan and those in these Waterfront Design Guidelines.

#### 2.1.1 Promenade Overlooks

Throughout the Waterfront in this District, promenade overlooks are proposed to be located at regular intervals along the water’s edge (Figure 3.C.2). The concept for the overlooks is an adaptation of the “floating lantern” concept developed in the *Public Spaces Master Plan*. The overlooks will provide a place that takes people out over the water and allows wider views towards the north to the causeway and the Napa River Bridge and south to the Carquinez Bridge. Overlooks will also create a more intimate gathering space for people to talk, rest, or fish. Light fixtures will accent the overlooks as well as create a punctuated design element that can be seen from afar and from the neighborhoods of Vallejo.



Figure 3.C.2: Locations of Seating Overlooks





Two options for the overlooks have been developed (Figures 3.C.4 and 3.C.6). Option 1 is a longer overlook with benches oriented to look across the Strait to Mare Island (See Figure 3.C.5 for a cross section of Option 1). Option 2 is smaller and has benches oriented towards each other that look up and down the length of the Strait (See Figure 3.C.7 for a cross section of Option 2); this option provides the opportunity for a small group to enjoy the views together or for a family to spend some time fishing together. The options can be alternated along the length of the Promenade. Other options could also be developed from this theme including corner overlooks at the north and south ends of the Promenade in the Central Waterfront.

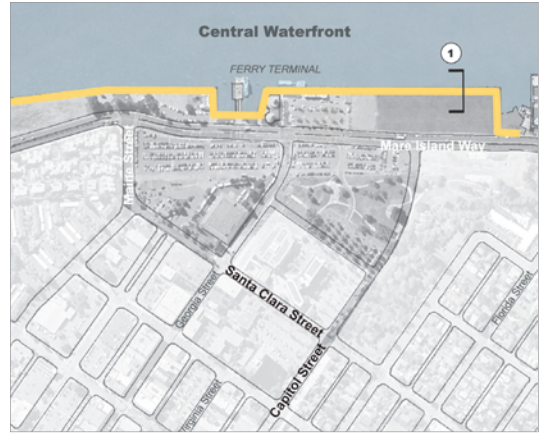

Figure 3.C.3: Section Location Diagram

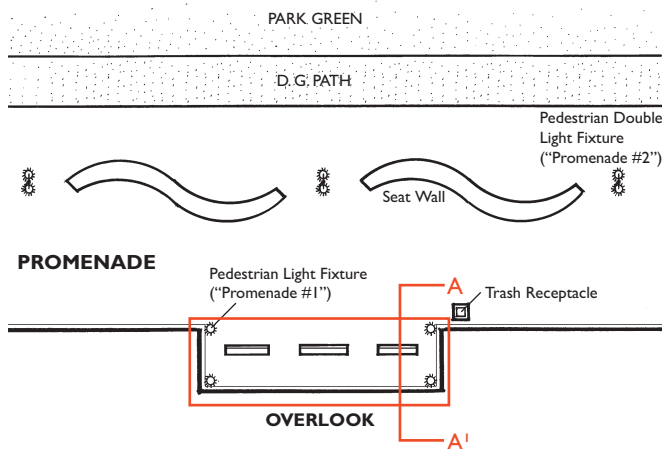

Figure 3.C.4: Plan of Proposed Promenade Overlook (Option 1)

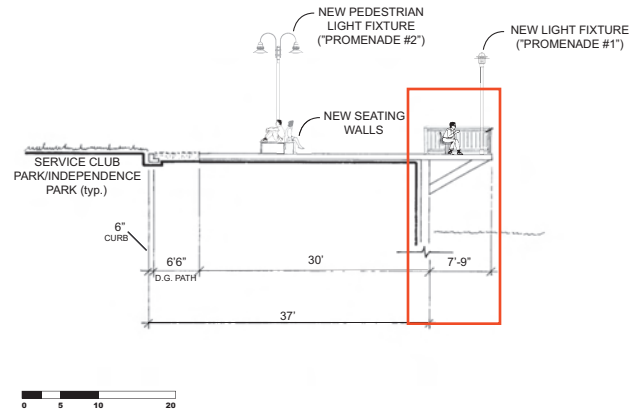

Figure 3.C.5: Cross Section A-A' of Proposed Promenade Overlook (Option 1)

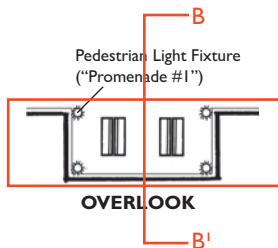

Figure 3.C.6: Plan of Proposed Promenade Overlook (Option 2)

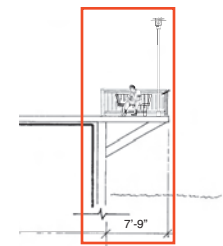

Figure 3.C.7: Cross Section B-B' of Proposed Promenade Overlook (Option 2)

### 2.1.2 Parks and Open Space

This section of the Guidelines provide specific guidance for the design of key open spaces within the Central Waterfront District. It includes improvement diagrams and key Guidelines that give direction regarding the critical aspects of future improvements, as well as sketch concepts of sample improvements as they might result from the Guidelines.

#### Northern End of Service Club Area (Area A)

The Service Club Area is the large green space bordered by the Promenade on its west and north sides, Mare Island Way on the east side, and the expansion area for the Festival Green on the south. Currently the area serves as an open un-programmed recreational space and is covered in turf; this function is valued by the community and should remain. The improvements described below would improve views, provide for better integration with the areas around the park, and provide additional amenities for those strolling along the Promenade or recreating on the green. The corner next to Mare Island Way is an important point of arrival into the Central Waterfront District for people who are coming along the Promenade from the north, which is also the most constrained area of the Promenade between the Vallejo Yacht Club parking lot and Mare Island Way.

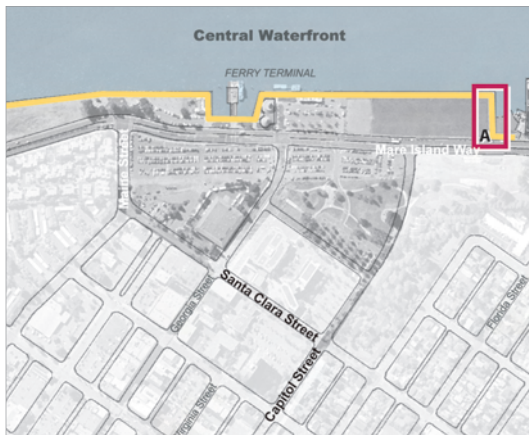

Figure 3.C.8: Key Map for Northern End of Service Club Area (Area A)

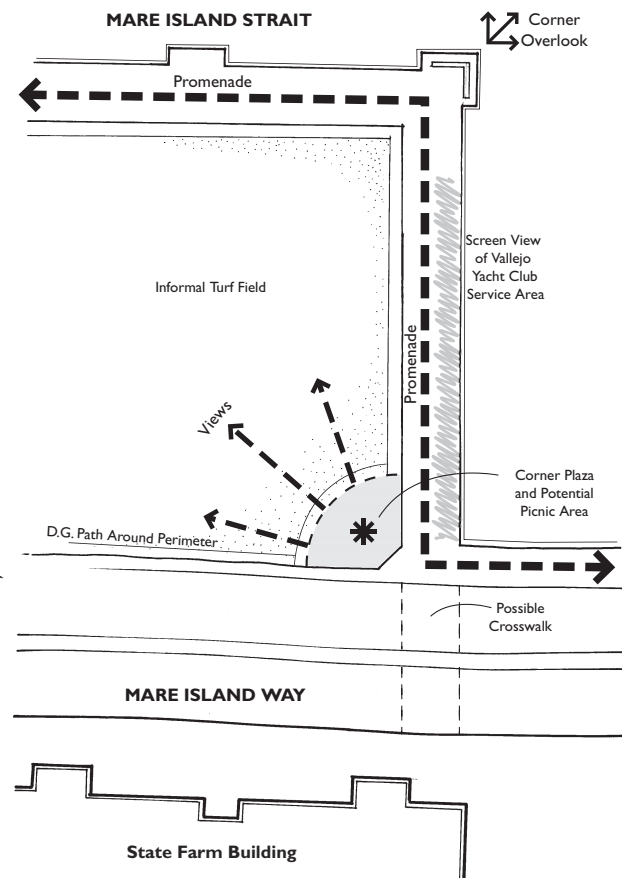

Figure 3.C.9: Guideline Diagram for Northern End of Service Area (Area A)

### Guidelines

1. Create a paved entry area on the northeast corner of the green space and focal point at the intersection of the Promenade and the sidewalk along the west side of Mare Island Way. This area could include a few picnic tables, seating for people who are watching others play on the green or taking a break from playing.
2. Verify feasibility of providing a crosswalk on Mare Island Way linking this area with the State Farm Building and the adjacent neighborhoods. This should be considered because the existing crosswalks are 950 feet apart and this new crosswalk would be approximately at the mid-point between the existing crosswalks.
3. Create a corner overlook at the northwest corner of the Promenade to accommodate seating and to take advantage of the dramatic views to the northwest.
4. Maintain unobstructed views along the entire edge of the Promenade, with the exception of the buffer landscaping described in the next Guideline.
5. Create a visual buffer to screen less attractive views directly to the north, into the service area of the Vallejo Yacht Club. The screening material could consist of a line of tall thin trees that filter the view, smaller leafed varieties of Eucalyptus could be appropriate as they are evergreen and would provide a visual linkage with the older established Eucalyptus trees that line the existing Promenade in the Northern Waterfront District.
6. The color and patterns of paving materials should strongly relate to circulation patterns throughout the area and be used to visually enhance the locations of focal points and features.
7. Use the standard “Waterfront” light fixture and street furnishings along Mare Island Way, and the standard “Promenade” light fixture and other street furnishings along the Promenade sides of the area.

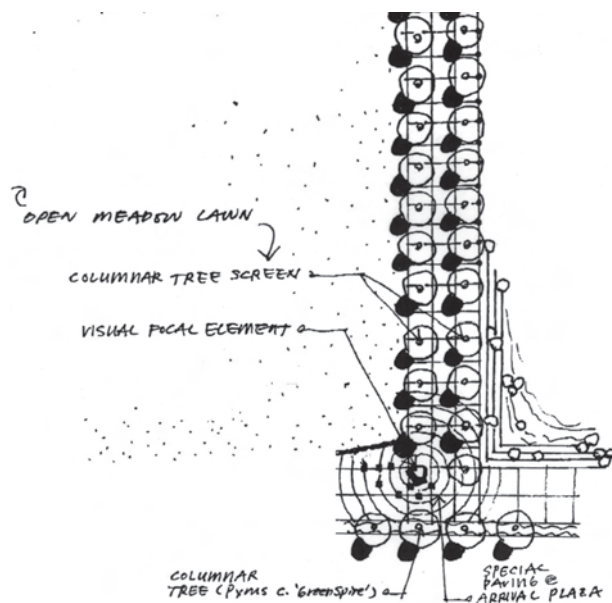

Figure 3.C.10: Sketch Concept for Northern End of Service Area (Area A)

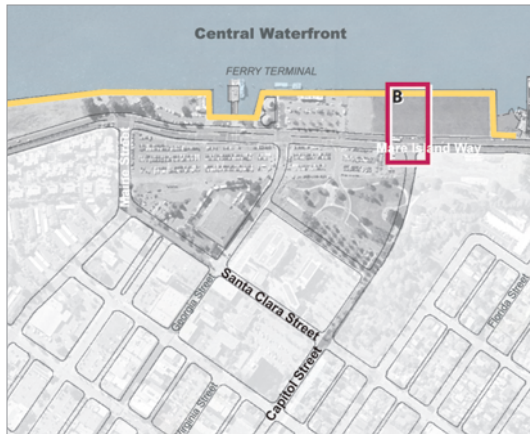

Figure 3.C.11: Key Map for Northern End of Service Club Area (Area B)

### Service Club Area at Capitol Street (Area B)

The large size of Service Club Area’s green space currently creates a separation, and at times, a barrier to pedestrian access between Mare Island Way and the Promenade. The green stretches 800 feet from north to south and if recreational activities are occurring in it pedestrians may be uncomfortable walking across the green. The Guidelines propose providing a narrow walk and landscaped area crossing through the middle of the green in-line with the intersection of Capitol Street and Mare Island Way (Figure 3.C.11). This improves the accessibility between Mare Island Way and residents and workers on its east side to the Waterfront Promenade while maintaining open recreational green areas of approximately 400 by 200 feet and 300 by 200 feet.

#### Guidelines

1. Reduce the distance between access points from Mare Island Way to the Promenade for pedestrians and provide a bulb-out on the west side of Mare Island Way, where Capitol Street terminates, to shorten pedestrian crossing distances and provide additional space for an entry plaza, described below.
2. Crosswalks with special paving should be installed to increase the visibility and safety of crossing locations.
3. Create a direct pedestrian connection between the Mare Island Way sidewalk and the Waterfront Promenade at the intersection of Capitol Street and Mare Island Way, as illustrated in Figure 3.C.12. This connection should include a paved entry area and should be lined with seating integrated with rows of trees, aligned parallel to Capitol Street to frame views of the Waterfront from the east. Seating and planting design should accommodate secondary, cross circulation patterns between the two green recreational spaces.
4. Provide a small, expanded plaza and landscaped entry between the enhanced crossing of Mare Island Way and the path across to the Promenade. This space will be an important gateway to the Waterfront Parks and open spaces.
5. Create a focal point with a special feature and paved area at the intersection of the pedestrian path and the

Promenade. The feature should be visible from along the Promenade, but not block pedestrian circulation. An overlook with seating should be created at the edge of the Promenade, as shown in Figure 3.C.13.

6. A plaza or slightly raised viewing area could also be provided between the Promenade and the green. This would provide a space for people to view across the Promenade to the Mare Island Strait from an elevated perspective, as well as a place for people to watch others playing on the greens.
7. Use the standard “Promenade” light fixture along the path connecting the Promenade and Mare Island Way.

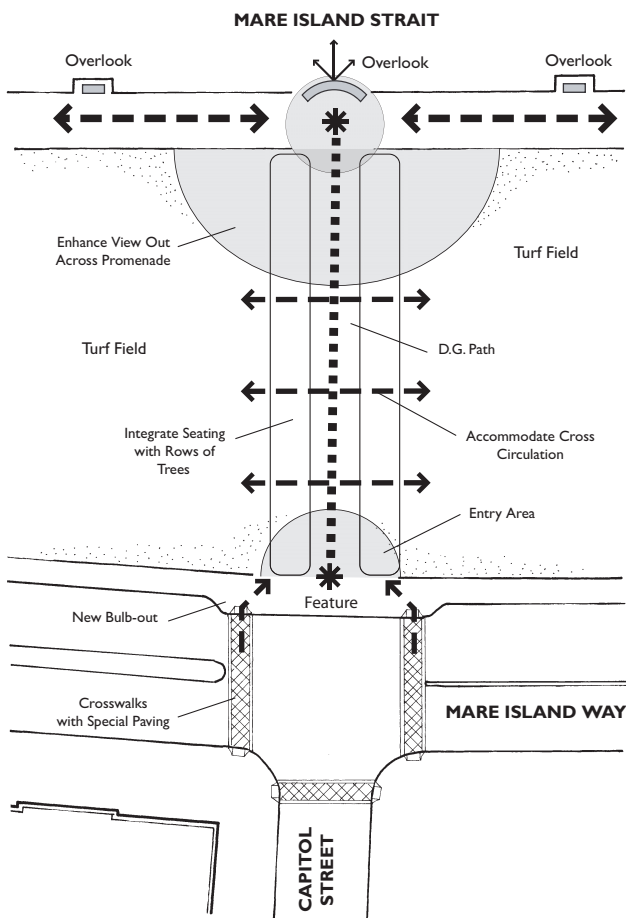

Figure 3.C.12: Guideline Diagram for Service Club Area at Capitol Street (Area B)

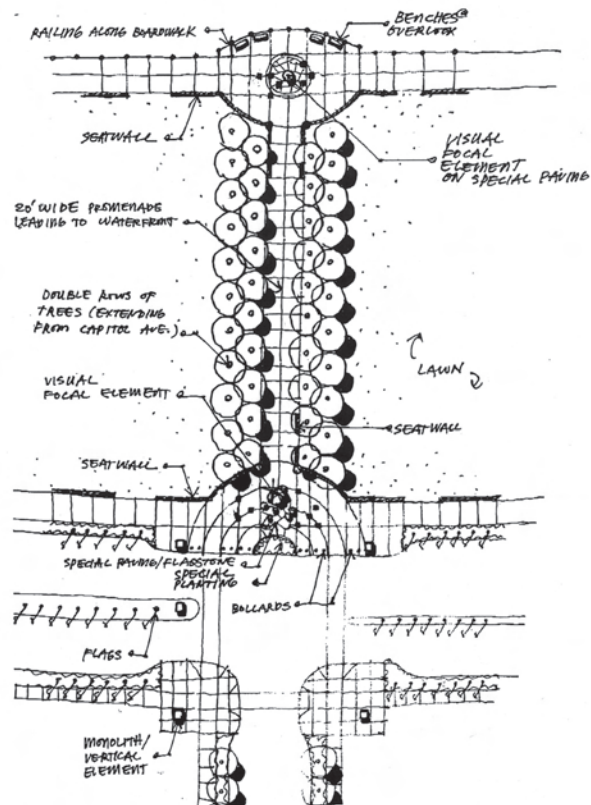

Figure 3.C.13: Sketch Concept for Service Club Area at Capitol Street (Area B)



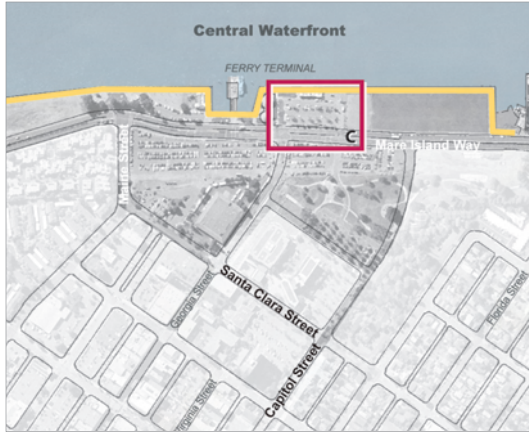

Figure 3.C.14: Key Map for Park and Drop-off Area North of Ferry Building (Area C)

### Park and Drop-off Area North of Ferry Building (Area C)

The area on the north side of the Ferry Building serves as an important circulation and activity node for the Central Waterfront. Design concepts for this area need to facilitate access to and from the Ferry Building’s north entrance and provide visual cues and connections between Mare Island Way, Downtown Vallejo, Vallejo Station, and other areas of the Waterfront. While the Front Room restaurant and surface parking occupy much of the area today, the restaurant leases the facility from the City and the City’s goal is to create an expansion of the Festival Green on this site. The program and amenities in the Festival Green expansion area should emphasize the relationship to the eastern Festival Green and the Ferry Building’s prominent role as a local landmark and transportation hub.

#### Guidelines

1. Create a kiss-and-ride drop-off loop on the north side of the Ferry Building. This facility should be configured in a U-shape and incorporate sidewalks and seating on its west side, as illustrated in Figure 3.C.15, to provide an outdoor area to wait for rides. The landscape treatment of the area should frame the views of people coming down Georgia Street towards the Mare Island Strait. The paving treatment in the loop area should be designed to visually integrate with the adjacent park space as the loop may be periodically closed to facilitate celebrations and other activities in the Festival Green expansion area.

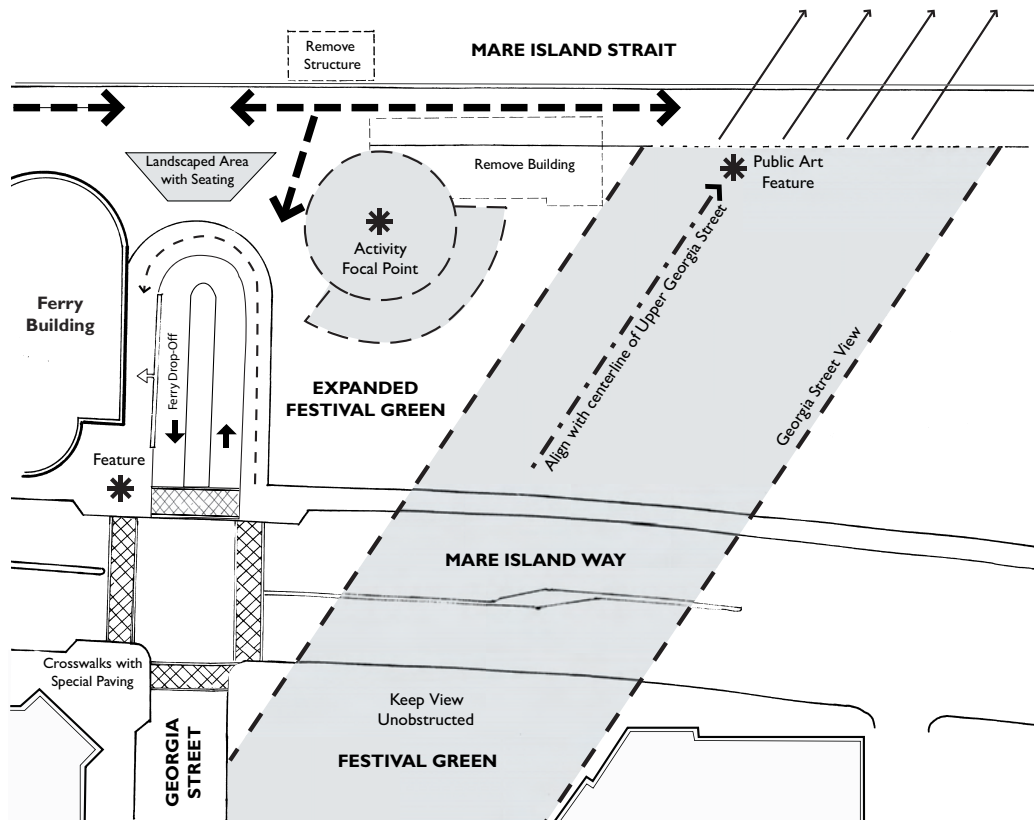

Figure 3.C.15: Guideline Diagram for Park and Drop-off Area North of Ferry Building (Area C)

2. Frame the entry to the Ferry Terminal with a new, moderately-scaled entry feature located between the Ferry Building and the kiss-and-ride loop.
3. Reduce the crossing distances for pedestrians crossing Mare Island Way at the Ferry Building by installing a bulb-out on the southeast corner of the intersection between Mare Island Way and Georgia Street (the final geometric design and feasibility of curb extension from a traffic flow perspective will be determined during the design development phase of future street improvements).
4. The museum building currently located on the east side of the Promenade, north of the Ferry Building should be removed. The Front Room restaurant located on the west side of the Promenade should be removed.
5. The open space in this area should be redesigned to create an active gathering space with seating and landscape treatments such as a fountain, or a raised platform that can be combined with a temporary bandshell for musical and other performances. Considerations for the orientation of a platform or bandshell should take into account the possible noise impacts from performances on residential areas in the Waterfront and adjacent residential neighborhoods. An orientation towards the water may contribute to the reduction of such noise impacts.
6. Preserve the open view corridor that extends the unobstructed views of the Waterfront from Georgia Street in the Downtown, as shown in Figure 3.C.15. To further emphasize the Georgia Street alignment, plant a row of trees as shown in Figure 3.C.16 to continue the row established on the east side of Mare Island Way. Create a vertical feature at the edge of the Promenade that is aligned with the center-line of Georgia Street.
7. Color and patterns of paving materials should strongly relate to circulation patterns throughout the area and be used to visually enhance the locations of focal points and features.
8. Use the standard “Waterfront” light fixture and street furnishings along Mare Island Way, and the standard “Promenade” light fixture and other street furnishings along the promenade side of the area.
9. The design of vehicular circulation through the kiss-and-ride loop located north of the Ferry Building should allow for vehicles in the inside driving lane to pass other vehicles stopped for drop-off along the outside edge of the loop. Lane dimensions and curb radii of the loop should be kept as compact as possible to keep vehicular speeds low, while accommodating efficient and convenient drop-off and pick-up.

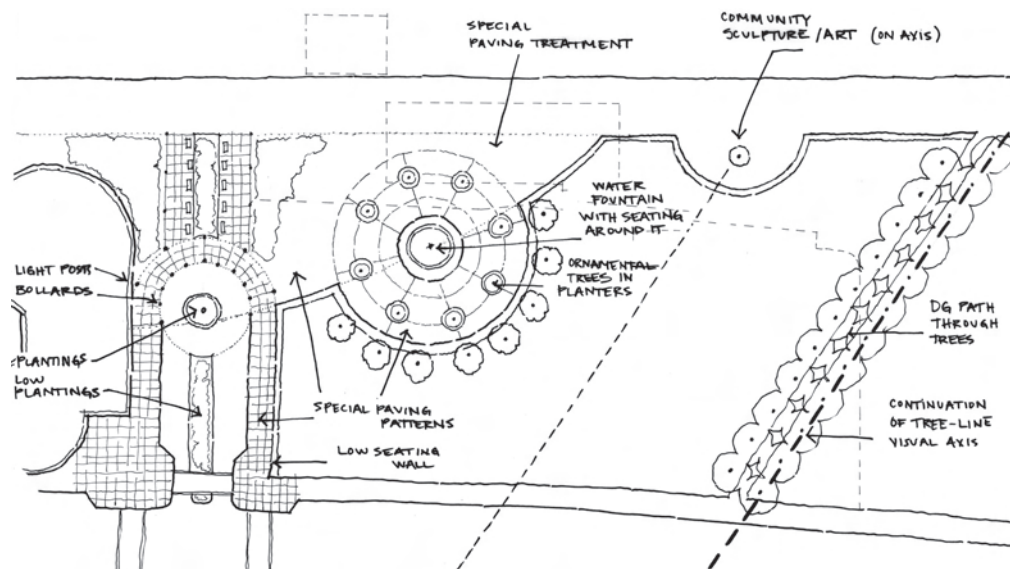

Figure 3.C.16: Sketch Concept for Park and Drop-off Area North of Ferry Building (Area C)

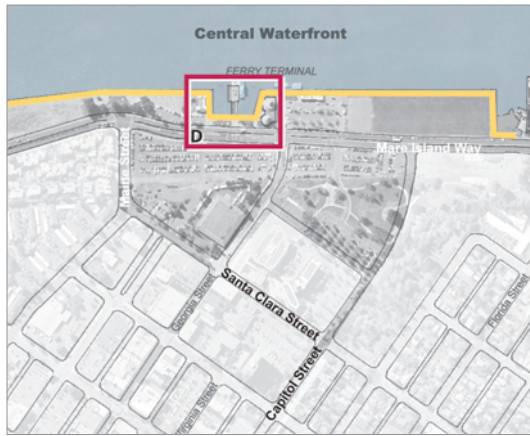

Figure 3.C.17: Key Map for Ferry Terminal Plaza (Area D)

### Ferry Terminal Plaza (Area D)

The Ferry Terminal Plaza, located south of the Ferry Building between Mare Island Way and the water's edge, is one of the most prominent and pivotal public open spaces along the Waterfront (Figure 3.C.17). It constitutes the gateway for transit riders arriving and departing from ferries and buses, and accommodates a series of important pedestrian linkages between the Waterfront Promenade, the Ferry Terminal building, ferry and bus transit waiting areas, and pedestrian crossings across Mare Island Way to Vallejo Station, Georgia Street, and the Downtown. At the plaza's southern edge there is a small, existing office building, which is leased from the City. The City plans to remove the building in the future and replace it with an open space use providing an additional amenity for this important area. As with the other open space Guidelines, the following Guidelines are provided as a starting point for the City's open space planning process with the public.

### Guidelines

1. Provide ample seating for transit riders waiting for the arrival/departure of buses and ferries.
  - a. The seating along Mare Island Way should be combined with or be integral to a landscaping area, such as raised planters, that provide a clear delineation between Mare Island Way and the Promenade while framing a plaza located on the axis of the pedestrian connection between the Ferry Terminal and the sidewalk of Mare Island Way. The provided seating should be associated with both bus stops and the Ferry Terminal.
  - b. The planters should be shaped to allow ferry riders to move easily from the entry of the Ferry Terminal pier to the bus stops and pedestrian crossings of Mare Island Way.
  - c. Select trees and other plants for the landscaping area that are compatible with the street trees along Mare Island Way.
  - d. Provide a minimum width of 16 feet between the curb edge of the bus bay and the edge of the seating/landscaped area, and minimum 8 by 5 foot clear zones as per ADA requirements at each bus door location.
  - e. Provide a minimum width of 20 feet between the Promenade's railing and the edge of the ferry-side seating/landscaped area.
  - f. Provide additional seating along the Promenade railing north of the entry to the Ferry Terminal pier for ferry riders to use when they "queue-up" while waiting for a ferry to load. The clear space between seating and railing should be 3 feet. The provided seating should consist of backless benches with armrests to allow people to sit facing either the Promenade or the water (See Figure 3.C.18); however, intermittent benches with backs and armrest should be provided to the extent required by most recent ADA Guidelines.
2. Color and patterns of paving materials should strongly relate to circulation patterns throughout the area and be used to visually enhance the locations of focal points and features.

3. Provide features such as information kiosks, small-scale structures or appropriately-scaled public art or monuments in the “Feature” locations identified in Figure 3.C.19. The most prominent of these features should be associated with the plaza on axis with the Ferry Terminal pier.
4. Frame the entry to the Ferry Terminal pier with a new, moderately-scaled entry feature, such as a gated arbor.
5. Use the standard “Waterfront” light fixture and street furnishings along Mare Island Way, and the standard “Promenade” light fixture and other street furnishings along the Promenade side of the area.
6. Maintain unobstructed views along the entire edge of the ferry basin.
7. Provide overlook seating areas that give definition to the outer northern and southern corners of the ferry basin; the concept for the overlook seating areas is described in *Section III.C.2.1.1 Promenade Overlooks*.



Figure 3.C.18: Ferry Queue Bench – Landscapeforms ‘Presidio’ Backless Bench With Arms

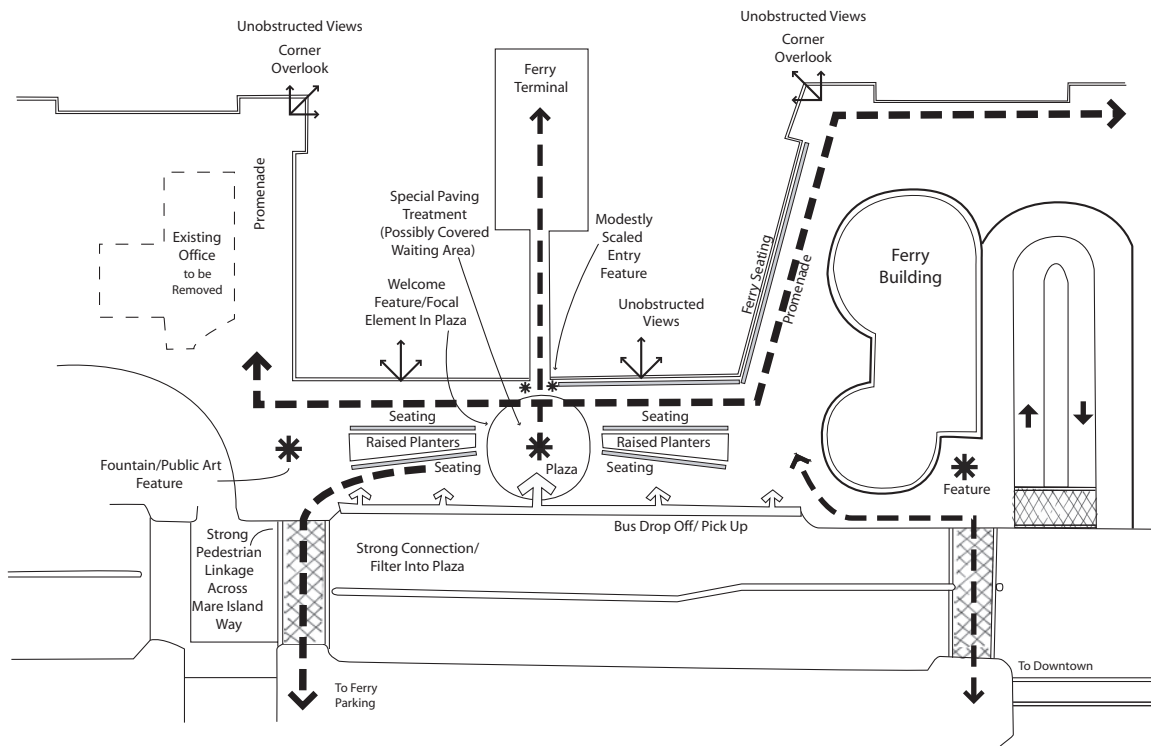

Figure 3.C.19: Guideline Diagram for Ferry Terminal Plaza (Area D)





Figure 3.C.20: Key Map for Southern End of Independence Park (Area E)

### Southern End of Independence Park (Area E)

The area of Independence Park located south of the existing Cypress grove consists of a large open grassy area that is bordered by the Waterfront Promenade on its west and south sides and Mare Island Way to the east. Although this area is currently underutilized, it affords some of the best scenic views of Mare Island Strait and Mare Island, especially from its southwest corner; currently, this part of the park is minimally developed. The Guideline concept, as shown in Figure 3.C.21, informs the future design of this corner to take full advantage of views to the Strait, Mare Island, and the Carquinez Bridge to the south while retaining the open quality of the site and preserving views across the site from Mare Island Way.

#### Guidelines

1. Enhance views across the Promenade from the southwest corner of Independence Park by creating a slightly elevated landscape feature that incorporates seating into its design. This feature could include a combination of earthwork, turf, paving, low retaining/seat walls and/or planters that provide opportunities to sit and view the water from above the Promenade. This feature should not exceed 3 feet-6 inches in height to maintain unobstructed views from Mare Island Way.
2. Create a special seating and viewing overlook to enhance views across Mare Island Strait at the southwest corner of the Promenade as shown in Figure 3.C.21.
  - a. The special lookout/ seating area should be cantilevered out over the water and should differ in its shape and/ details from the other “typical” lookouts proposed along the Promenade. It should serve as a distinct and recognizable landmark for this special location along the Promenade.
  - b. Provide a minimum width of 3 feet between the Promenade’s railing and seating. The provided seating should consist of backless benches without armrests to allow people to sit facing the water, the Promenade, or others seated in the overlook.
3. Provide bicycle and pedestrian access around the east and north sides of the elevated viewing area described in Guideline 1. This path should provide a more direct line of travel for bicyclists and pedestrians



who cut through the green rather than stay on the Promenade. The “standard” overlook proposed along the Promenade north of the corner lookout described in Guideline 2, should be aligned with the terminus of the bicycle/ pedestrian path.

4. Enhance the existing pedestrian connection between the Promenade and the sidewalk along Mare Island Way at the southeast corner of Independence Park.
  - a. Replace the existing narrower path with a wide paved area of similar width as the Promenade, approximately 20 feet.
  - b. Install an entry feature at the junction of the bicycle/pedestrian path and the Promenade, where the Promenade forms a right-angle (Shown in the Guideline diagram Figure 3.C.21). The feature could consist of a kiosk, public art, an interpretive sign, or lighting fixture.
  - c. Install a secondary feature along the western Mare Island Way sidewalk at the improved connection to the Promenade. This feature should direct pedestrians’ attention to the connection to the Promenade and the Waterfront and may consist of special paving or plantings.

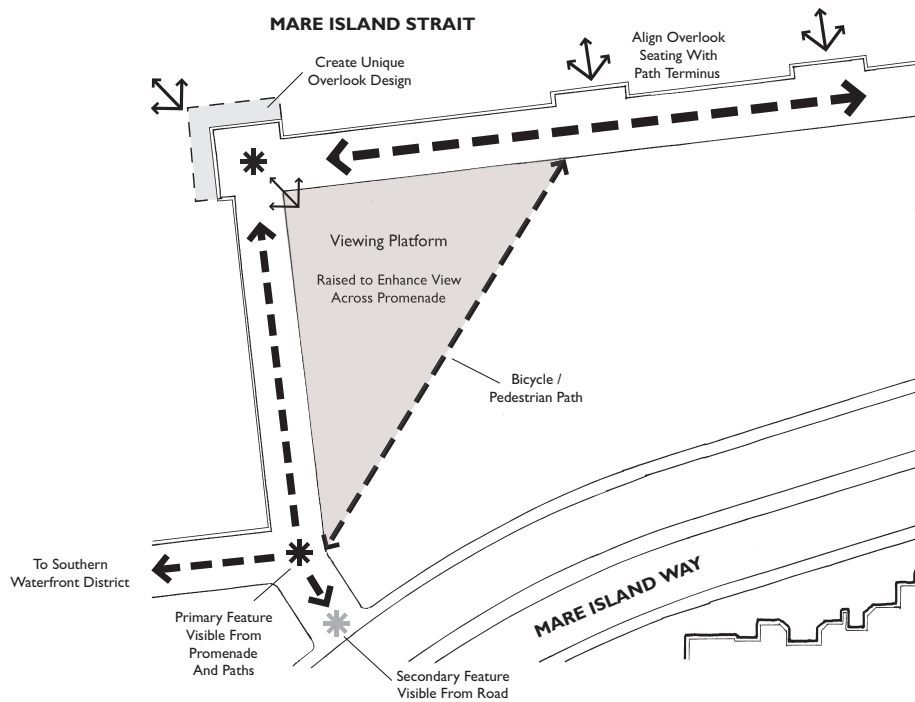

Figure 3.C.21: Guideline Diagram for Southern End of Independence Park (Area E)

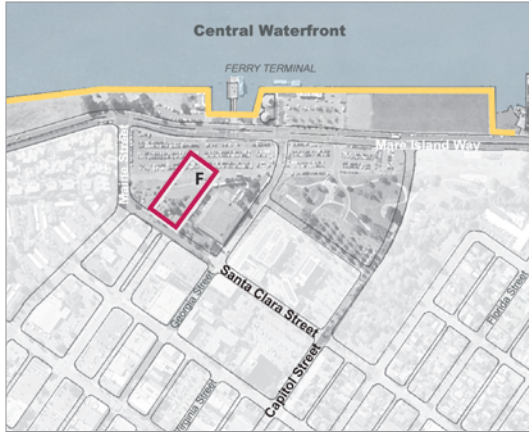

Figure 3.C.22: Key Map for Vallejo Station Paseo Park (Area F)

### Vallejo Station Paseo Park (Area F)

The Paseo Park in Vallejo Station provides a key link between the Waterfront, Vallejo Station, and Downtown Vallejo. The Paseo Park is located on top of the ferry parking garage that will be provided under Vallejo Station. The Park will be at the grade of Santa Clara Street. As the Paseo Park is raised a level above Mare Island Way there will be dramatic views to the north, including views of the Ferry Building, the waterfront parks and open space, Mare Island and the Strait.

As well as being an important public space in the Central Waterfront District, the Paseo Park is also an important open space for the residential and other uses of Vallejo Station that front onto it. It will need to provide a transition between public space and the entries to residential and commercial uses, and possibly provide some passive recreational use for surrounding residents.

It is possible that the Vallejo Station parking garage could be built in two phases. During the interim Phase 1, a three level parking structure would be built with the top level constructed with 250 parking spaces and a pedestrian path instead of the Paseo Park. The pedestrian path would be a minimum 18-foot wide paved surface connecting Santa Clara Street and the Bus Transfer Center with Mare Island Way and the ferry and bus services. The ultimate development of the parking garage will implement Phase 2, which would remove the 250 parking spaces at ground-level available to ferry patrons to construct the Paseo Park. A total of 50 parking spaces would be included within the Paseo Park for short-term parking. This parking may also be constructed in two phases. Initially, 25 parking spaces would be built with the remaining 25 spaces to be constructed upon City determination they are necessary. In the interim, landscaping will be provided within this space as defined in the Design Guidelines.

### Guidelines

1. The landscape treatment and special features within the Paseo Park should frame and leave open views from Santa Clara Street through to the Waterfront.
2. The north end of the Paseo should provide a viewing area out to the north and a special feature such as a trellis or open tower element.
3. The paving of drive aisles, parking spaces and the turn around should be of special materials, such as concrete pavers or colored concrete with highlights of stone, brick, or other special finishes to indicate to drivers that they are in a park space and to expect high levels of pedestrian activity.
4. The low-speed vehicular circulation environment within the Paseo Park needs to provide:
  - access to the parking for the residential building to the north;
  - short-term parking for visitors to the residences and other uses around the park, as well as for customers of the retail, restaurants, and other uses in Vallejo Station and the nearby parts of Downtown<sup>1</sup>; and,
  - emergency vehicle access, including access for fire trucks and ladders to the buildings that face onto the park and a turn around at the west end of the Paseo Park.

Figures 3.C.23, 3.C.24 and 3.C.25 illustrate three alternative approaches to achieving the above circulation needs. If other solutions are explored during the design development for the final Vallejo Station buildings, they should follow the Guidelines provided in this section.

5. The sidewalks, paths, and plazas need to provide for pedestrians passing through the Paseo to uses on either end.
6. **Vallejo Station Ferry Parking Phasing** – During the period in which the parking garage includes 250 parking spaces at the ground level with Santa Clara instead of the Paseo Park, a minimum 18-foot walkway should be included on the northern end of the parking level. The walkway should be constructed of special decorative paving that differentiates this

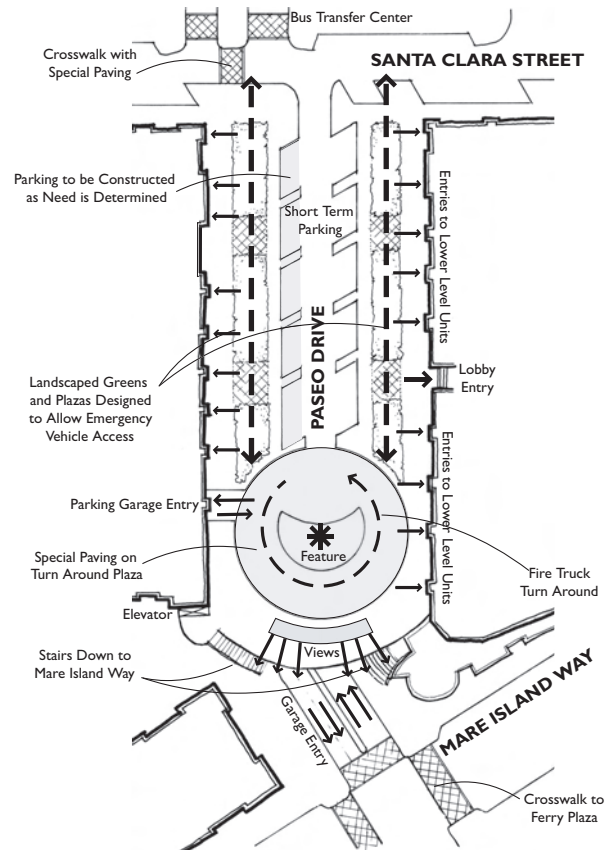

Figure 3.C.23: Guideline Diagram for Vallejo Station Paseo Park (Area F)

space from the remainder of the parking lot, with a raised curb six inches above the grade of the travel lane.

7. The interim 18-foot walkway should be landscaped with raised planters on the side adjacent to the travel lane to create a comfortable pedestrian space. Planters should contain medium-sized flowering trees to add color to this important connection and should be located no further than 20 feet on-center. Tree species could include Crape Myrtles (*Lagerstroemia x. 'Muskogee'*), Tristania (*Tristania Laurina Multi-Trunk*), or Flowering Pear (*Pyrus Kawakamii*).
8. **Paseo Park Short-Term Parking Phasing** – During the period in which the northern row of parking along the drive aisle remains unused for parking, a combination of paved hardscape and landscaping in planters and/or pots should be provided to tie the area into the adjacent landscaped open space from both a design and functional standpoint. Seating could also be provided to further integrate the area with the open space.
9. Stairs need to provide connections from the Paseo Park down to the plaza at the parking garage entry and the east side of Mare Island Way. An elevator should also provide access between the Paseo Park, the plaza on Mare Island Way, and the parking garage under the Paseo Park.
10. A crosswalk with special paving should connect the Paseo Park across Santa Clara Street to the Bus Transfer Center that is planned on the Downtown block to the east.
11. The Paseo Park should include multiple pathways from Santa Clara Street to the west and be designed to serve the various pedestrians such as people rushing to catch the ferry, residential guests, conference center/restaurant patrons or people strolling through Vallejo Station to the waterfront parks and open space.

12. Use the “Downtown” traditional light fixtures and street furniture within the Paseo Park to strengthen the relationship with Downtown.
13. Trees within the Paseo Park should include Evergreen Elms (*Ulmus Parviflora*) if feasible given the parking garage structure. If Canary Island Palms (*Phoenix Canariensis*) are the tree used on Mare Island Way these should also be used, particularly to highlight and frame views at the western end of the Paseo Park. The use of flowering trees with fall color, such as Ornamental Pear (*Pyrus Calleryana ‘Aristocrat’*), is also encouraged to highlight special areas in the Paseo Park.
14. The north and south sides of the Paseo Park are fronted onto by Vallejo Station buildings, including a conference center/restaurant, a portion of the hotel located on the north side, and residential buildings on the south side. Uses should provide active frontages onto the Paseo Park such as outdoor dining and gathering spaces along the conference center and restaurant frontage, retail storefronts, residential stoops or stairs to individual units, residential lobbies, entries to residential internal courtyards that provide views of the interior landscape, and entries to ground-level live/work units.

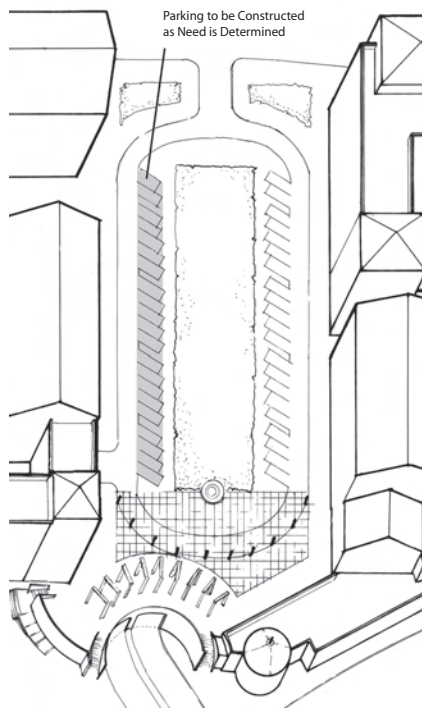

Figure 3.C.24: Sketch Concept for Vallejo Station Paseo Park (Area F)

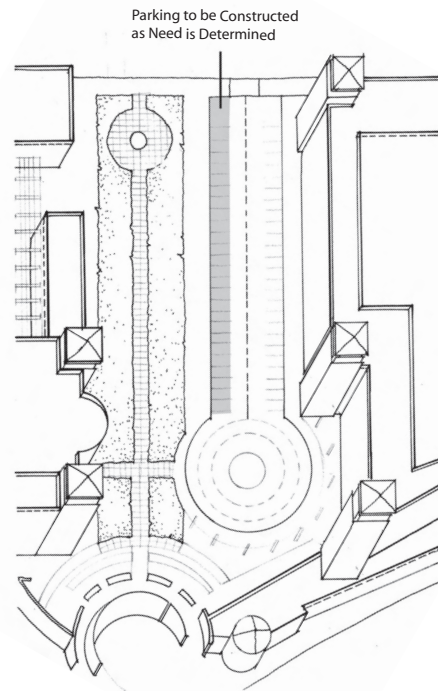

Figure 3.C.25: Sketch Concept for Vallejo Station Paseo Park (Area F)



### ***Festival Green Extension South of Dr. Martin Luther King Jr. Unity Plaza***

1. Extend westward the double-row of trees and the rows of Downtown light fixtures already established in the Dr. Martin Luther King, Jr. Unity Plaza area and maintain the same spacing of both elements. Place a 14-foot wide (min.) path with ornamental paving, between the two rows of trees.
2. The path between the buildings and the Festival Green would extend as a hardscaped surface from the edge along the lawn area to the edge of a continuous walk in front of the retail storefronts (See Figures 3.C.26 and 3.C.27). Because of a grade change from Dr. Martin Luther King, Jr. Unity Plaza to Mare Island Way, some portions of this continuous walk along the storefronts will connect to the public walk with continuous steps. The number of required steps would increase with distance from Dr. Martin Luther King, Jr. Unity Plaza, where no steps are necessary and handicapped access to the continuous walk can occur. At the Mare Island Way end of the public walk, a public plaza should be created. Elevator or ramp access to the continuous walk should become an integral part of the design of this plaza.
3. For additional Guidelines see *Section III.C.2.2.1.B Civic Center Drive*.

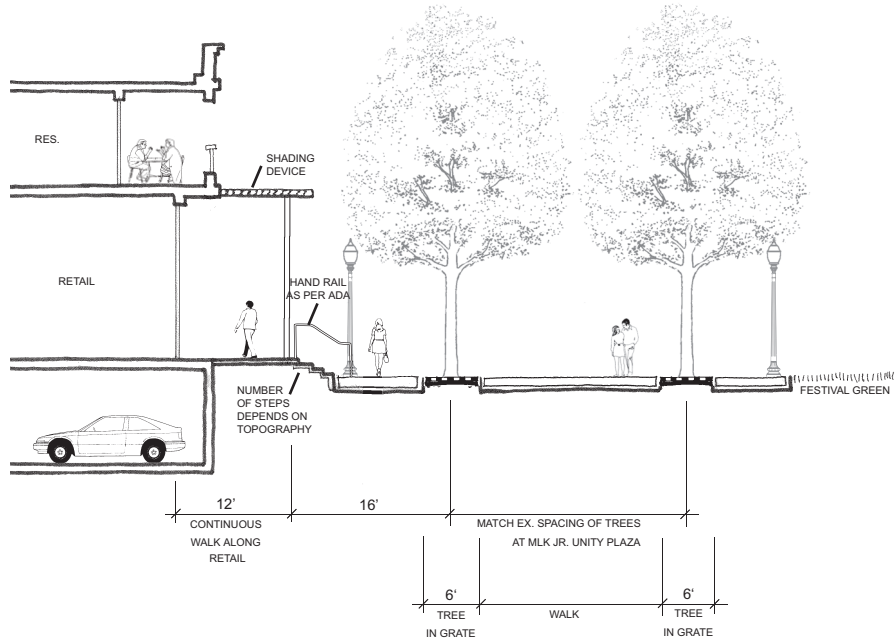

Figure 3.C.26: Partial Cross Section of Retail Frontage along Festival Green

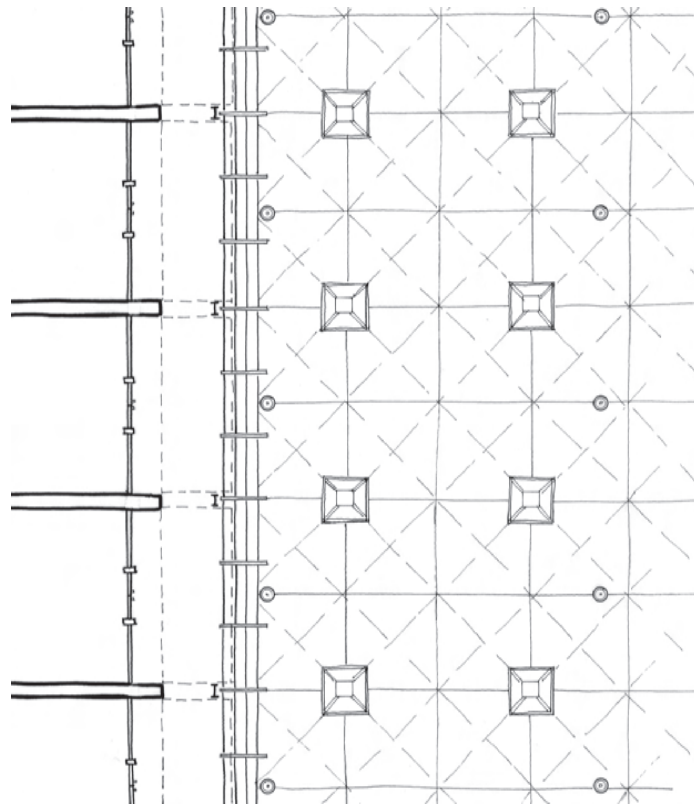

Figure 3.C.27: Plan View of Retail Frontage along Festival Green

### **Public Paseo Through Residential Block**

A Public Paseo should be included in the residential development between Civic Center Drive and Mare Island Way. This Paseo should:

1. Be a minimum of 40 feet wide.
2. The north and south sides of the Paseo should be fronted onto by residential buildings, which provide active frontages onto the Paseo, including residential stoops or stairs to individual units, residential lobbies, and entries to residential internal courtyards that provide views of the interior landscape.
3. Incorporate high-quality landscaping that includes trees, shrubs, and groundcovers; and provides additional amenities such as pedestrian-scale light fixtures and seating.
4. Terminate at Mare Island Way by widening its dimension to create an inviting space with a concentration of amenities toward Georgia Street to the south. The space should have a strong presence within the Mare Island Way frontage and consideration should be given to the incorporation of public art in this location.

## **2.2 Circulation Guidelines**

### **2.2.1 Street Guidelines**

The Guidelines contained in the following sections focus on the pedestrian realm and its relationship to adjacent development and uses.

#### **2.2.1.A Georgia Street Extension**

Georgia Street is the civic and main street connecting Downtown Vallejo and the Waterfront. On the Vallejo Station side of the street it will be lined by a mix of uses that may include retail, ground-floor financial, insurance and real estate services; or hotel lobbies with hotel or office above. Opposite, on the north side of the street, is the civic heart of Vallejo including the Public Library, City Hall, Dr. Martin Luther King, Jr. Unity Plaza, and the Festival Green where civic, cultural, and community events take place. Georgia Street also acts as the primary link between these uses and the Waterfront and its amenities, including the Ferry Terminal. Georgia Street

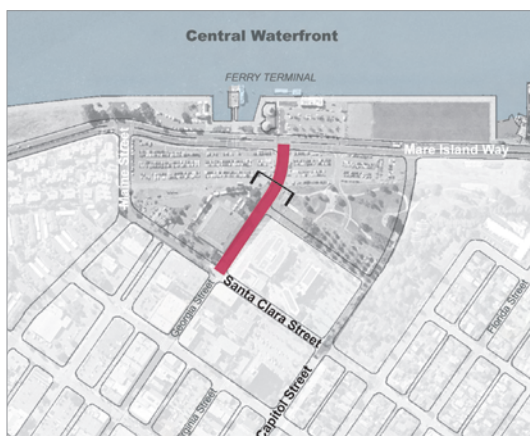

Figure 3.C.28: Georgia Street Extension and Section Location Diagram

will see large volumes of pedestrian activity and, as a result, the intersection of Georgia and Mare Island Way will become the most visible and visited corner of the Waterfront. In order to strengthen this link, the Guidelines treat this street as a continuation of the Downtown by extending the design specified for Georgia Street in the Downtown Specific Plan and Guidelines to this section of the street. In addition, the proposed treatment of the street builds on concepts discussed in the Downtown Specific Plan including the preservation of views from Georgia Street across the existing civic open space of Dr. Martin Luther King, Jr. Unity Plaza and the Festival Green, through the Central Waterfront and across the strait to Mare Island. The long term goal of redeveloping the northern parking lot at the Ferry Terminal and of “The Front Room at the Wharf” restaurant will further strengthen the physical and visual linkage between the Waterfront and Downtown.

Figure 3.C.29 illustrates the proposed section for Georgia Street. As in the Downtown, it includes an 18-foot sidewalk to accommodate the high amount of pedestrian traffic foreseen for this street and to provide sufficient room for shoppers to window shop, and restaurants and cafés to place small tables or chairs along their storefronts without obstructing the clear space for pedestrians moving along the street. Furnishings used along Georgia Street, such as benches, trash receptacles and light fixtures will all match those used in the Downtown portion of Georgia Street to further strengthen the linkage between the Waterfront and the Downtown. This includes using the Downtown light standards on both sides of the street (*See Section II.B Street Trees, Lighting and Furnishings*).

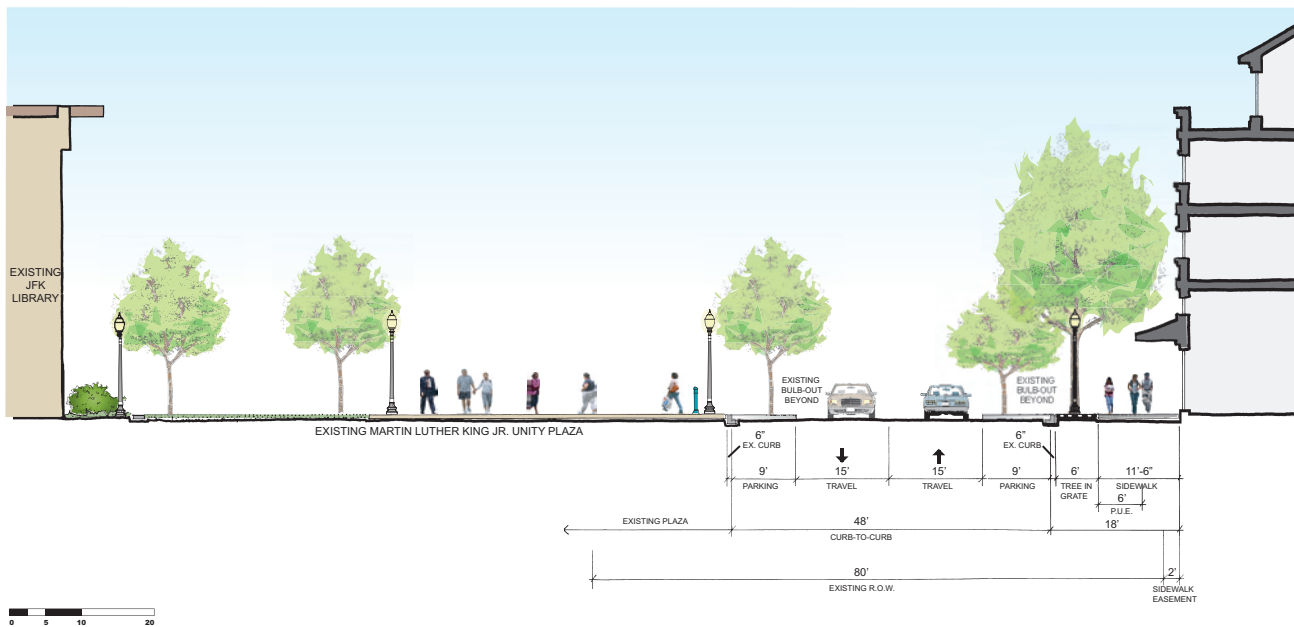

Figure 3.C.29: Section of Georgia Street Extension at Dr. Martin Luther King, Jr. Unity Plaza

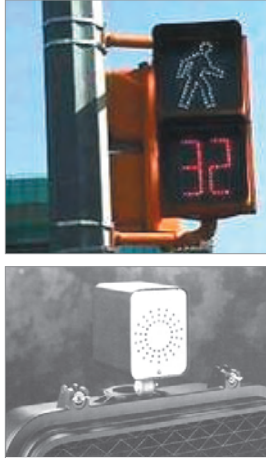

Figure 3.C.30: Crosswalk System with Countdown Signal and Audible Device for the Visually Impaired

### Georgia Street Extension Crossing Design

Safe and convenient pedestrian crossings are a critical component for the design of a successful main street. This is particularly true in an area with a mix of uses that provides visitors with the opportunity to link visits to multiple destinations into a single walking trip. Such an environment exists along Georgia Street west of the Downtown, which will not only attract shoppers but also people visiting one of the several civic buildings in the area, relaxing or playing on the Festival Green, congregating in Dr. Martin Luther King, Jr. Unity Plaza, traveling to and from the ferry, or visiting open spaces in other parts of the Waterfront while being in the area. High quality crosswalks are needed at the intersections of Georgia and Santa Clara, the proposed Civic Center Drive, and at Mare Island Way.<sup>2</sup> The following Guidelines apply to the crossings at intersections along Georgia Street.

#### Intersection of Georgia and Santa Clara Streets

Crosswalks that include key design elements already exist at the Georgia at Santa Clara intersection.

Pedestrian countdown signals that indicate the remaining pedestrian signal “green time” should be considered for this intersection.

#### Intersection of Georgia Street and Mare Island Way

To successfully implement the envisioned connection of the Downtown to the Vallejo Waterfront along Georgia Street it is essential that functional and safe crosswalks across Mare Island Way be provided which create strong visual linkages between both sides of the street.

Curb extensions should be provided on Mare Island Way to shorten the current, considerable crossing distance (the final geometric design and feasibility of curb extension from a traffic flow perspective will be determined during the design development phase of future street improvements). The curb extension at the southeast corner can be integrated into the crosswalk on the south side of the intersection and should be 20 feet wide to provide sufficient space for larger crowds crossing at times when departures or arrival of ferries occur. On the south side of the intersection a 4-foot wide pedestrian refuge at the end of the narrow median adjacent to the left-turn lane creates a refuge for pedestrians unable to complete the crossing of



Mare Island Way during a single pedestrian signal period. Pedestrian countdown signals should be provided for all directions of travel at this intersection to let pedestrians know how much time they have to cross the street and if they should wait for the next signal.

The surface of the Mare Island Way crosswalks should be given an artistic treatment that ties in with the design theme of future improvements around the Ferry Building and plaza, and the Waterfront Promenade in this area. This will enhance the visual integration of the Festival Green on one side of the street and the open spaces and Promenade on the Waterfront.

### 2.2.1.B Civic Center Drive<sup>3</sup>

The proposed Civic Center Drive constitutes an important addition to the street grid in the Central Waterfront District and establishes a new link for pedestrian, bicycle, and vehicular travel between Capitol and Georgia Streets. At its northern end, the street provides access to the City Hall parking lot as well as residential uses on the block on its western edge, which could include a parking structure serving uses located at its southern end. Civic Center Drive will define the eastern edge of the Festival Green as well as the western edge of Dr. Martin Luther King, Jr. Unity Plaza. Highly visible crosswalks are critical at this non-signalized T-intersection.

Should Civic Center Drive be constructed to intersect with Georgia Street, removable bollards should be provided at both edges of the Festival Green such that through traffic to and from Georgia Street is prohibited during non-peak hours; however, pedestrian access to and from Georgia Street should be maintained at all times. Also, special paving should be installed at the intersection to visually continue the line of the Festival Green across Civic Center Drive (See Figure 3.C.31).

It is possible that Civic Center Drive could be built to not intersect with Georgia Street, but merely serve as an access street for parking and driveways for the residential development on Parcel J, City Hall and the Public Library (See PDMP). In this case, the street could terminate in one of two ways: the street could end at the furthest point where a driveway would need access from either side of the street or it could terminate at the edge of the Festival Green. Driveways should not be located directly adjacent to the Festival Green terminus. Rather, storefronts

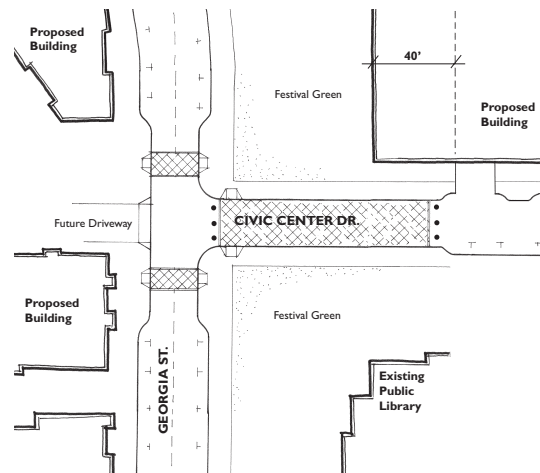

Figure 3.C.31: Georgia Street/Civic Center Drive Intersection Alternative

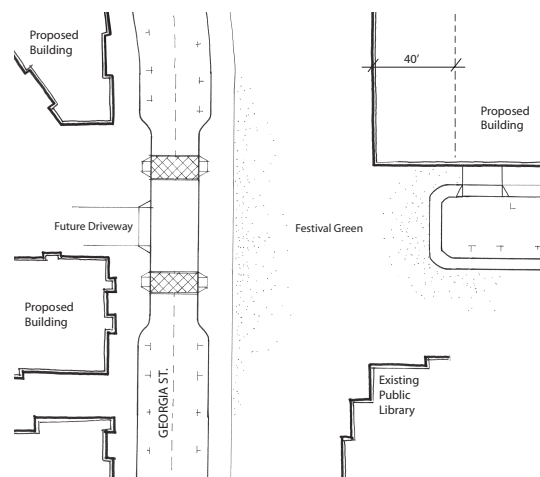

Figure 3.C.32: Festival Green Extension at Civic Center Drive Alternative

should form the continuous frontage along the Festival Green. This would allow the Festival Green to become a continuous pedestrian-only open space from Santa Clara Street to Mare Island Way. The allee of trees would form a continuous line down the park. Parking lots and access driveways should be designed to allow vehicles to use them as turn around space (See Figure 3.C.32).

Figure 3.C.33 illustrates how a landscaped setback on the east side of the street provides a buffer between the sidewalk and the proposed new public parking structure located in the former City Hall surface parking lot. On the west side of the street a 13-foot wide landscaped setback creates a transition area between the public realm of the sidewalk and street, and the private realm of porches associated with the residential first-floor uses along this frontage of Civic Center Drive.

Sidewalks on both sides of the street should be 12.5 feet wide and include street trees that are planted in 6-foot square tree wells (See Figure 3.C.33).

Light fixtures and furnishings along this street will match those used in the Downtown. The Evergreen Elm (*Ulmus Parviflora*) is the street tree proposed for this street to create a relationship between this street, Georgia Street, and Santa Clara Street.

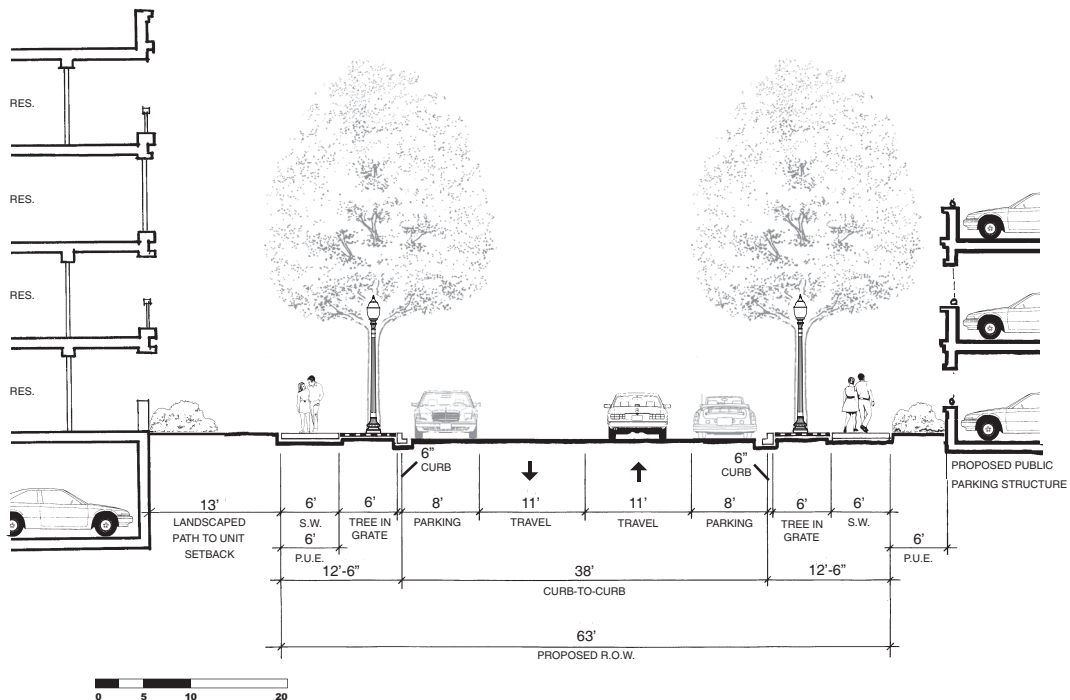

Figure 3.C.33: Cross Section of Civic Center Drive at Residential and Public Parking Garage

### 2.2.1.C Santa Clara Street South of Georgia Street

Future and existing first-floor retail uses anchor both street corners of Santa Clara Street just south of the Georgia Street intersection. The proposed mixed-use development of Vallejo Station establishes an important transition and link between the future Bus Transfer Center located at mid-block on the east side of the street and retail destinations along Georgia Street. Two mid-block pedestrian crossings will link the Bus Transfer Center to the west side of the street, to Vallejo Station's Paseo Park, and through the Paseo Park to the Ferry Terminal and bus stops on Mare Island Way (See Figure 3.C.35). Curb extensions are to be maintained or installed at the proposed mid-block crossing between the Bus Transfer Center and Vallejo Station and Paseo Park (the final geometric design and feasibility of curb extension from a traffic flow perspective will be determined during the design development phase of future street improvements).

There are three principal options for the design of Santa Clara Street south of Georgia Street. All three options achieve the sidewalk width for the Vallejo Station side of the street as called for in the *Vallejo Downtown Specific Plan* and *Design Guidelines*. The design options also provide for a parking arrangement that is similar to that described in the *Downtown Specific Plan* which includes diagonal parking on the west side of the street and parallel parking on the east.

**Option 1** achieves the desired sidewalk dimension of 14 feet on both sides of the street by moving the existing curbs toward the center of the existing roadway by 4 feet, (See Figure 3.C.36). This is the design as illustrated in the *Downtown Specific Plan*.

**Option 2** achieves the desired sidewalk dimension of 14 feet on the west side of the street only by widening the existing sidewalk onto the Vallejo Station site and on top of the ferry parking structure; (See Figure 3.C.37). This will maintain all existing curbs.

**Option 3** achieves the desired sidewalk dimension on the Vallejo Station side of the street by moving the curb 4 feet to the east, keeping the existing bulb-out at the intersection with Georgia Street (See Figure 3.C.38).

The use of tree grates at all street tree locations provides a total sidewalk width of 14 feet from curb face to building fronts, which is appropriate for the expected levels of pedestrian volumes along this street. Light standards and street furnishings along Santa Clara Street will match those of the Downtown. As on Civic Center Drive, the Evergreen Elm (*Ulmus Parviflora*) is the street tree proposed for this street; this corresponds with the street tree for this street as identified in the *Downtown Specific Plan*.



Figure 3.C.34: Santa Clara Street and Section Location Diagram

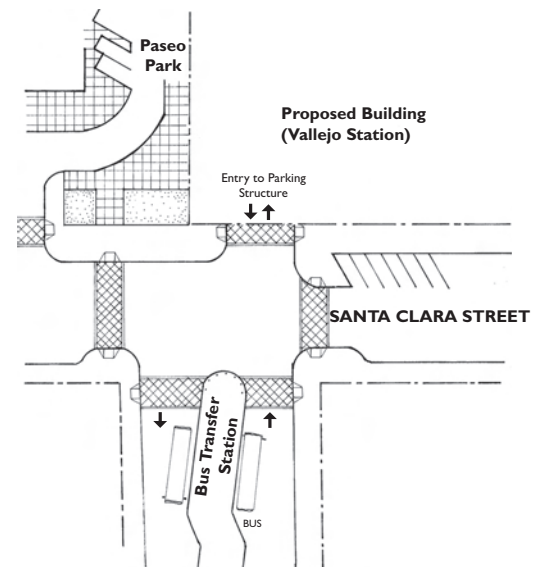

Figure 3.C.35: Concept Plan of Reconfigured Santa Clara Street Transit Center

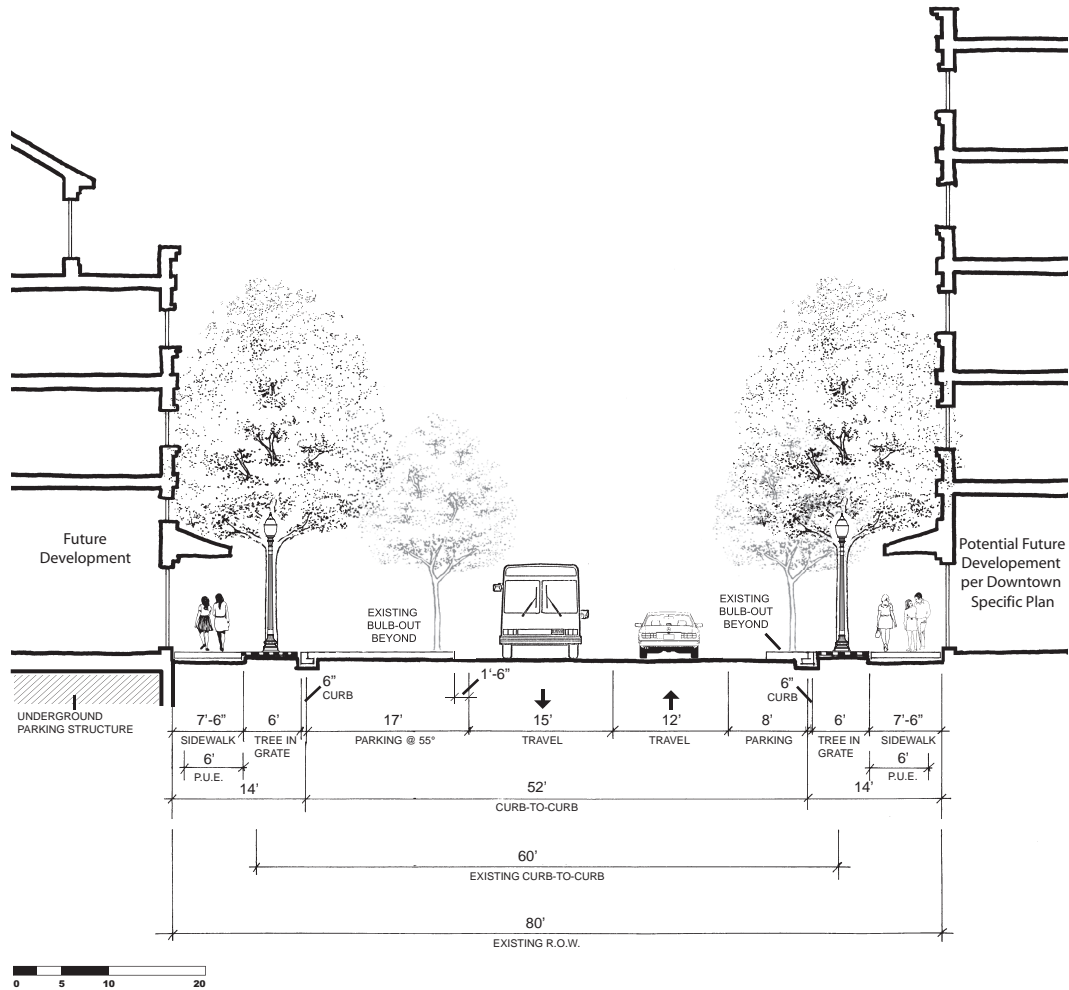

Figure 3.C.36: Santa Clara Street Cross Section (Option 1)

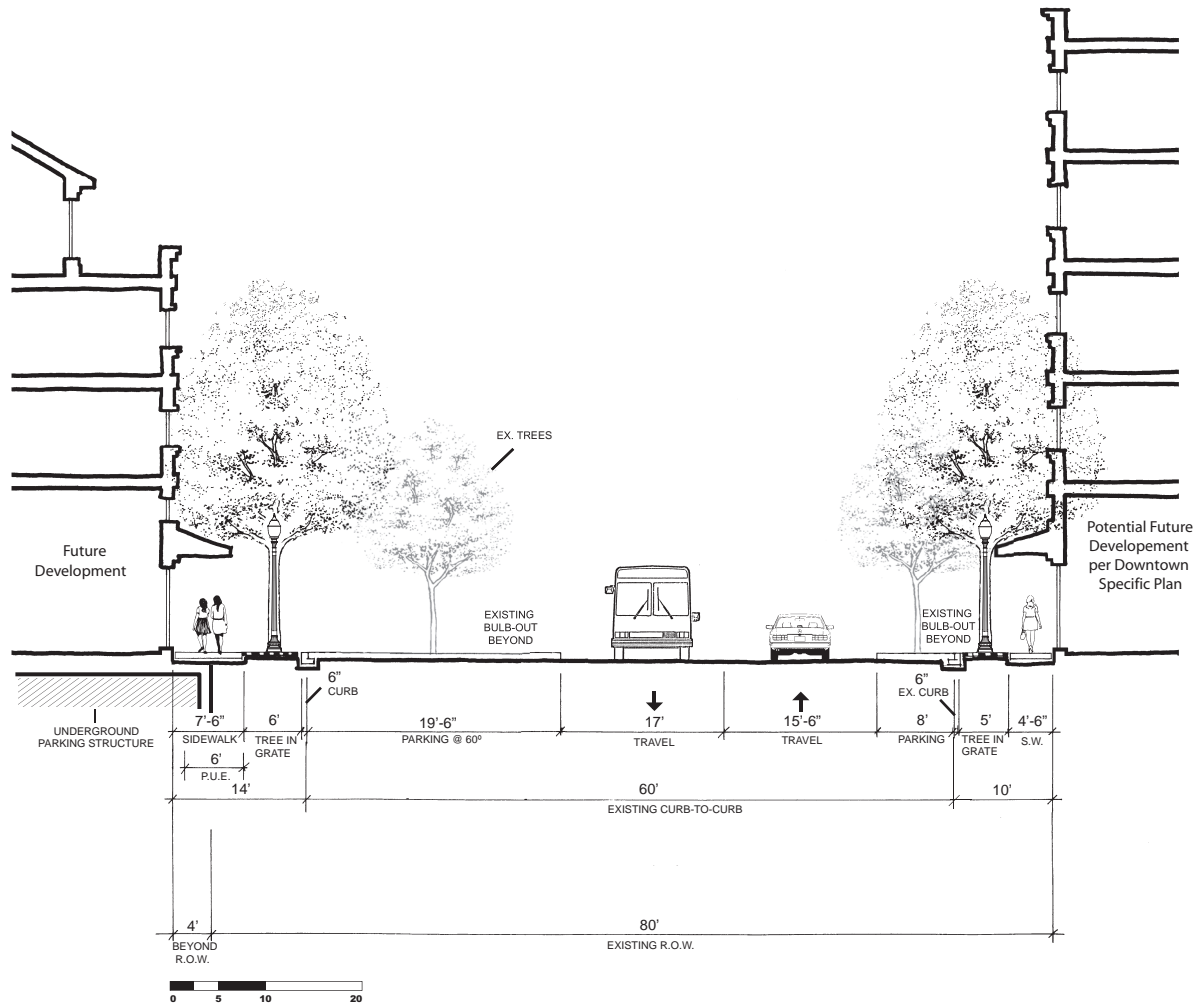

Figure 3.C.37: Santa Clara Street Cross Section (Option 2)



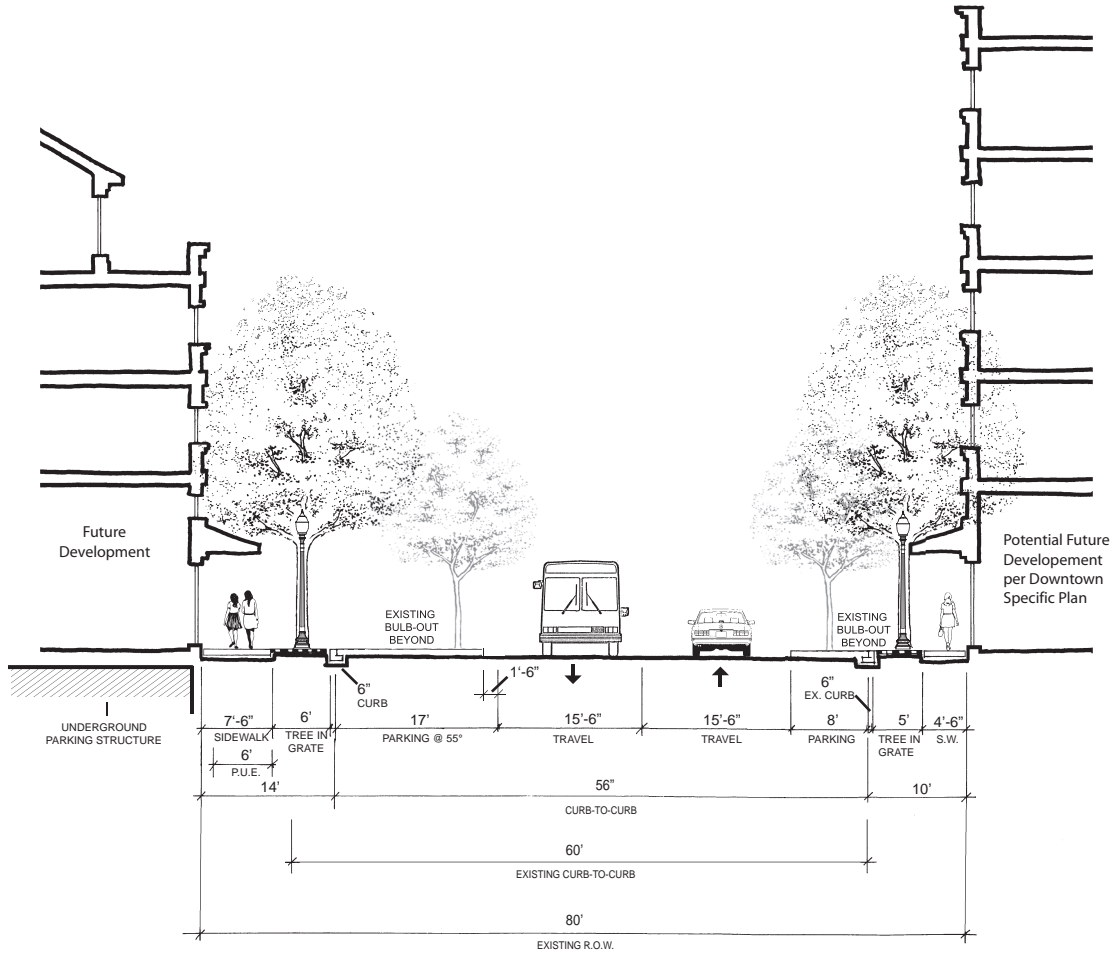

Figure 3.C.38: Santa Clara Street Cross Section (Option 3)

2.2.1.D Santa Clara Street North of Georgia Street

Figure 3.C.39 illustrates that the proposed new public parking structure on the west side of the street will be separated from the sidewalk by a 10-foot deep landscape buffer. The 14-foot width of the sidewalk matches the width proposed for Santa Clara Street south of Georgia Street. This sidewalk width is consistent with that illustrated in the *Downtown Vallejo Specific Plan*.

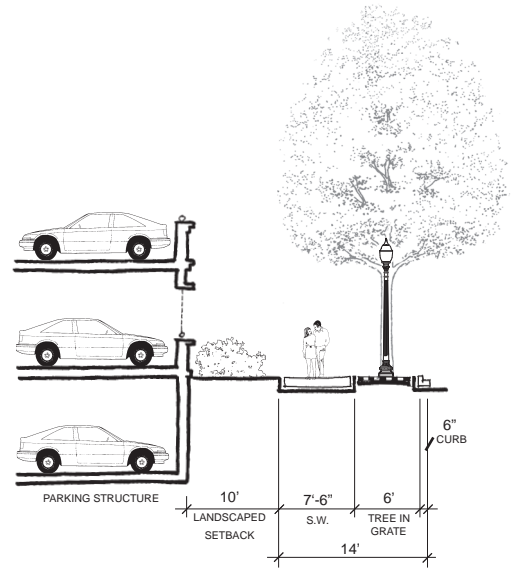

Figure 3.C.39: Partial Cross Section of Santa Clara Street at Public Parking Garage (in current surface parking lot of City Hall)



Figure 3.C.40: Maine Street and Section Location Diagram

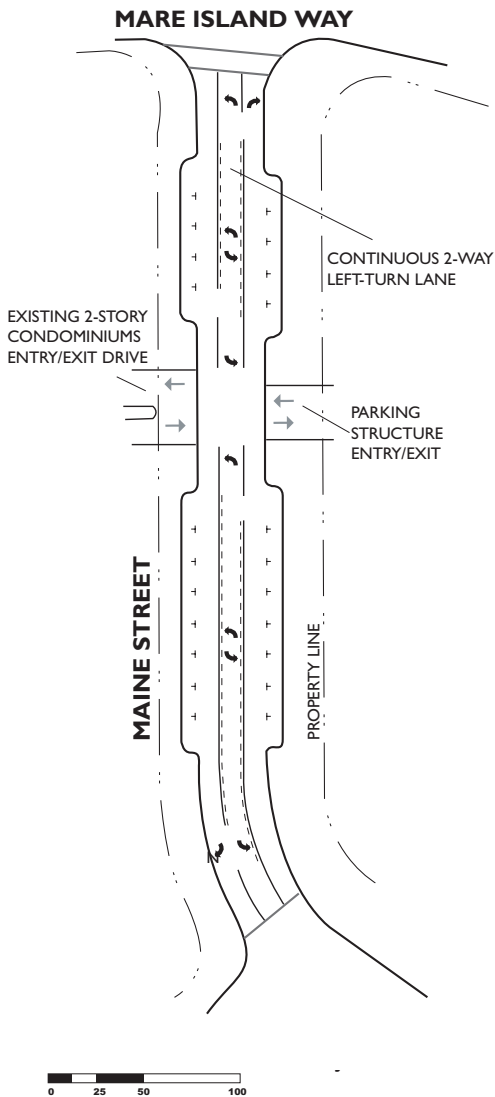

Figure 3.C.41: Concept Plan of Reconfigured Maine Street

### 2.2.1.E Maine Street

Maine Street is an important east-west link between residential areas in the vicinity of the Downtown and the Waterfront. The street provides access to an existing townhouse complex on the south side of the street as well as to the underground garage underneath the proposed condominiums on this side of the Vallejo Station development.

The topography of the Vallejo Station site, which includes a 9-foot drop along Maine Street between the Santa Clara/ Maine Streets intersection and Mare Island Way, creates a condition where portions of the underground parking structure will be exposed above the sidewalk surface along much of the length of the street. This condition furthermore creates the need for stairs or stoops to access the entries of residential units facing the street. In order to counter-balance the visual impacts of an exposed parking garage on the pedestrian environment along Maine Street, Maine Street should be reconfigured (Figures 3.C.40 and 3.C.41). The proposed reconfiguration will reduce the number of lanes from four to three and combine all left-turn movements in a continuous two-way left-turn-lane at the center of the roadway. This turn lane will serve all left turns occurring off of Maine Street (at the ends of the block onto Mare Island Way, Santa Clara Street, and within the block into the existing townhouse complex, and the proposed garage under the new Vallejo Station condominiums). On-street parking is provided along both the north side of Maine and around the corner on Mare Island Way to serve the retail commercial uses in the ground floor of the new building.

Figure 3.C.42 illustrates the cross-section that results from this reconfiguration of the street. The curb on the north side of the street is moved away from the buildings on the Vallejo Station site in order to create the space necessary to accommodate the stairs and stoops to the residential units, and a 6-foot wide landscape buffer between stair locations, as well as a wider sidewalk that provides space sufficient to accommodate the number of pedestrians expected along this street. The combination of entry patios, stairs, and landscaping will activate and buffer the edge of the parking garage to create an attractive “address” for the condominiums fronting onto Maine Street, as well as create a more comfortable environment for pedestrians walking along Maine.

The existing curb and landscape buffer along the townhouse complex on the south side of the street will be maintained in its current location.

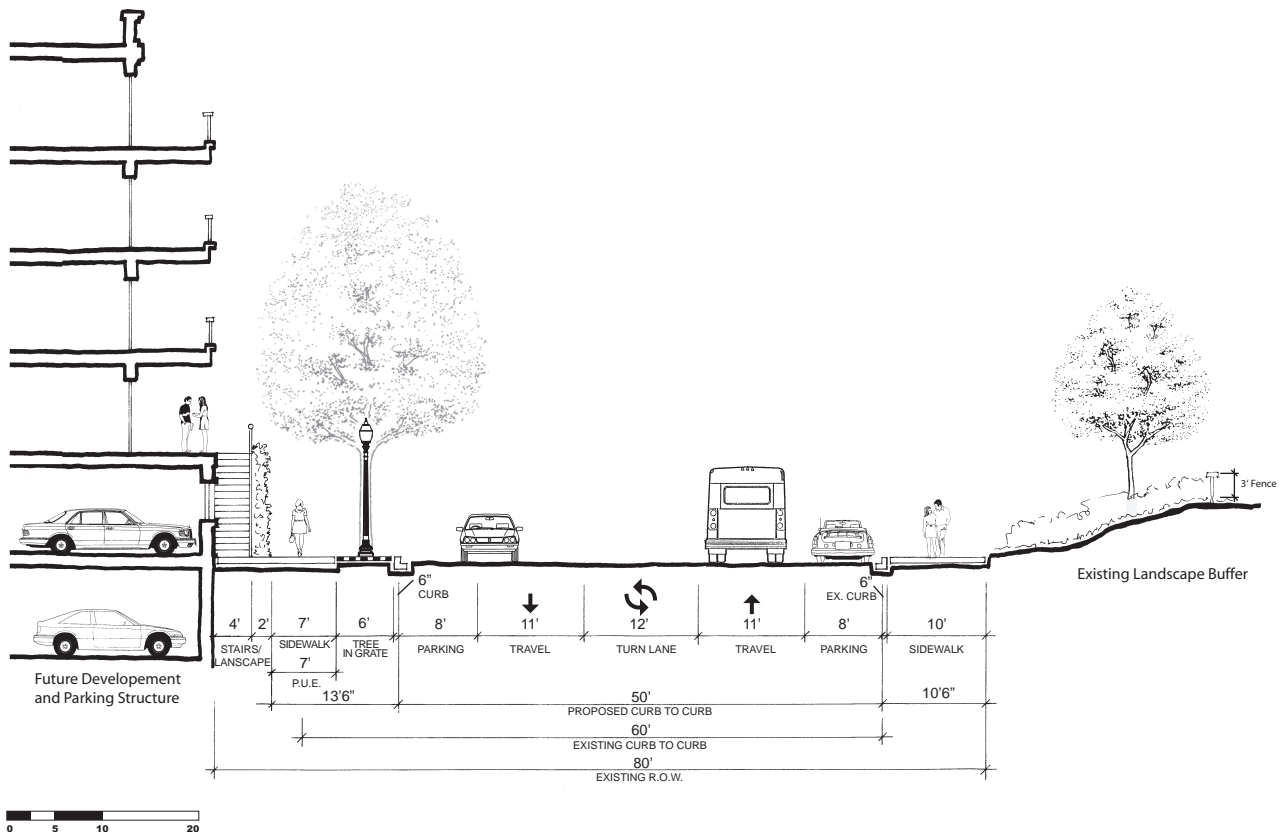

Figure 3.C.42: Maine Street Cross Section

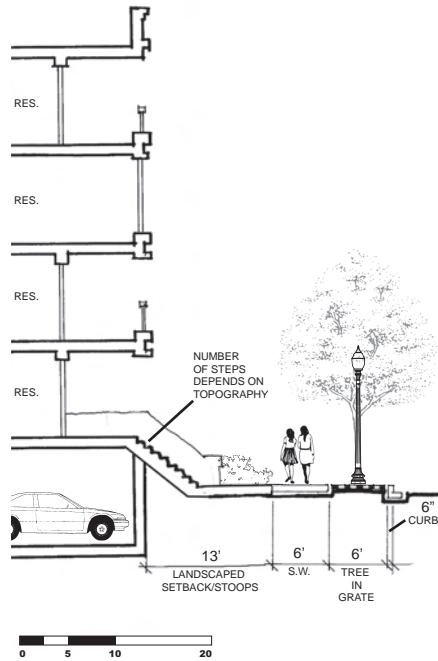

Figure 3.C.43: Partial Cross Section of Capitol Street at Residential

### 2.2.1.F Capitol Street West of Civic Center Drive

As illustrated in Figure 3.C.43 sidewalks along Capitol Street west of Civic Center Drive will be 12.5 feet wide. Like on Civic Center Drive, a 13-foot landscaped setback provides a transition between the public and private realm. Because of the changes in grade along the street between Civic Center Drive and Mare Island Way, portions of the frontage will include stairs to porches or stoops of the individual residential units. Central lobbies may also front the street.

East of Civic Center Drive, Capitol Street will be fronted on to by the proposed public parking structure. Here the sidewalk will continue at the same width as described above but be separated from the side of the parking structure by a landscaped buffer of 10 feet.

The traditional Downtown light fixture should be used on this street. Red Maple (*Acer Rubrum*) is the designated street tree.





Figure 3.C.44: Mare Island Way and Section Location Diagram. (For a description of section nos.1 and 2, see Northern Waterfront Section 2.3.3.B; For a description of section no.8 see Southern Waterfront Section 2.2.1.F.)

2.2.1.G Mare Island Way

**Mare Island Way from Kentucky Street to Capitol Street**

Improvements in this section of Mare Island will likely be minimal for the foreseeable future, as it was recently improved and little or no new development is planned in this area. Yet installation of pedestrian fixtures attached to the existing roadway fixtures and the planting of street trees to match the rest of the street would support the concept of Mare Island Way serving as a major linkage between the three Waterfront Districts. (Note: this section is repeated in *Waterfront Districts – Northern Waterfront, Section III.D.2.3.3.B Mare Island Way* due to overlap in District boundaries)

**Mare Island Way from Capitol Street to Festival Green**

Figures 3.C.45 and 3.C.46 illustrate the section of Mare Island Way at new residential development between Capitol Street and the future Extension of the Festival Green. Figure 3.C.45 shows the proposed conditions for future improvements. Figure 3.C.46 shows proposed improvements if the building use along this frontage is solely residential. Both alternatives assume a parking structure to be built underneath the buildings, which, while at grade at Civic Center Drive, would be partially exposed along Mare Island Way.

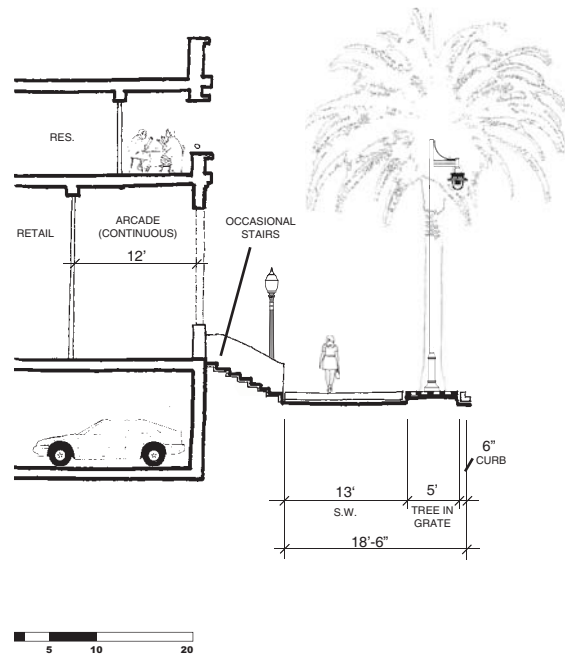

Figure 3.C.45: Partial Section of Mare Island Way at Retail (Parcel J1) ③

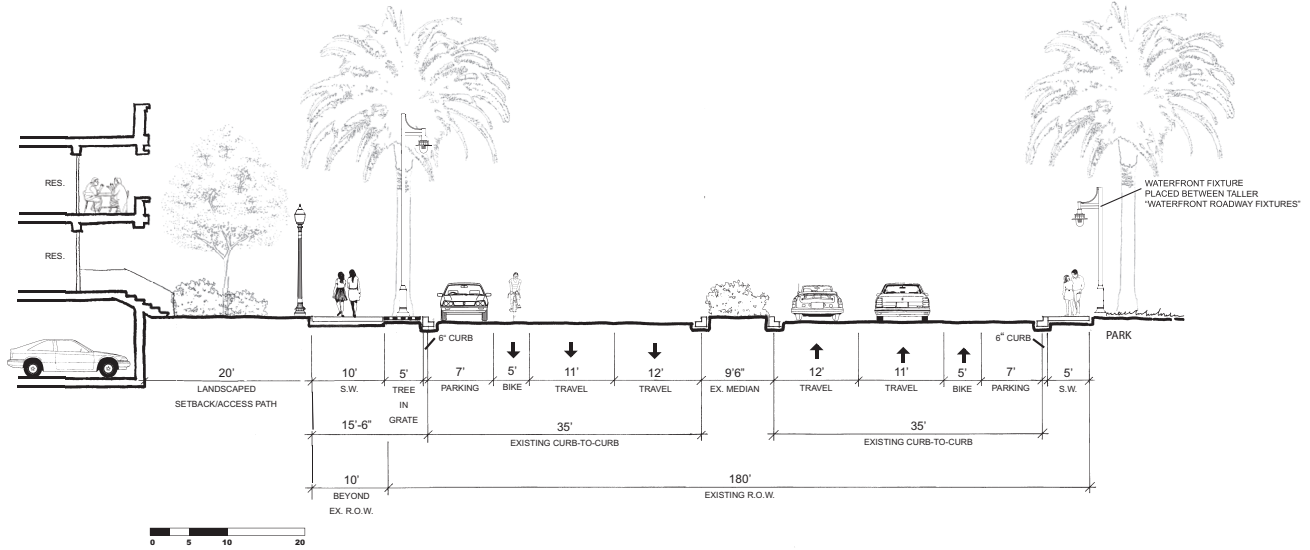

Figure 3.C.46: Section of Mare Island Way at Residential (Parcel J2)

**First-floor Retail:** Parcel J1 along Georgia Street and Mare Island Way, retail uses along the first floor frontage of the building will include an arcade (Also see *Section III.C.2.1.2 Parks and Open Space: Festival Green Extension South of Civic Center Drive in Central Waterfront*) accessed by sets of stairs from an 18.5-foot wide sidewalk on Mare Island Way; for Parcel J2 first-floor retail is an optional design. This sidewalk width is consistent with that proposed along the Vallejo Station frontage south of the parking garage entry. (See *Section III.C.3.1.1.B Building Frontage* and *Section III.C.3.1.4.A Parking Structures* for Guidelines on the desired treatment of exposed walls of the parking structures).

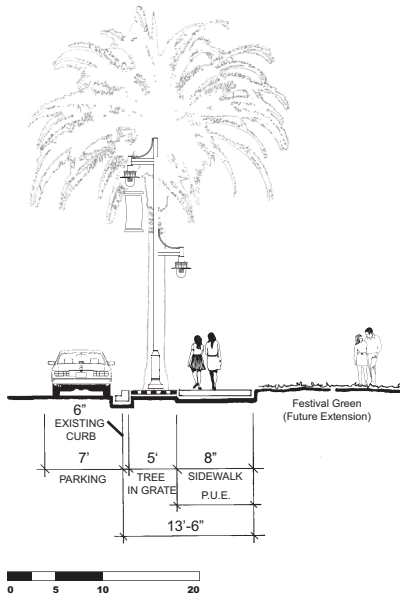

Figure 3.C.47: Final improvements along Mare Island Way at future extension of Festival Green

**First-Floor Residential Option:** In the case of Parcel J2's frontage onto Mare Island Way, residential units are set back from the street by a 20 foot landscaped area and accessed via stoops from a 15.5-foot sidewalk along Mare Island Way.

Throughout this block, the Waterfront street light fixture (used along all of Mare Island Way) should be combined with the pedestrian-scale Downtown post top fixture to convey the sense of proximity to Georgia Street and its linkage into the Downtown area to the east. The Design Guidelines encourage the use of the Downtown light fixture as the pedestrian-scaled fixture on the east side of Mare Island Way from Capitol Street to Marin Street to define the relationship of the Central Waterfront and Downtown Vallejo. Proximity to the important nexus of Georgia Street, Vallejo Station, and the Ferry Terminal should be further conveyed by the use of banners mounted to the Waterfront street lights in this area.

The section also illustrates how 5 foot bicycle lanes can be incorporated into the cross section of the street with out moving curbs (See Figure 2.46). This is critical to the goal of providing bicycle lanes along the sections of Mare Island Way that currently lack this important element.

**West Side of Mare Island Way Adjacent to Festival Green to North End of Ferry Building**

Planned Final Improvements: It is the City’s intention to redevelop the area that is currently to the north of the Ferry Terminal and across from the Festival Green into a continuation of the Festival Green to the Waterfront Promenade. When this occurs, the width of sidewalk on the west side of Mare Island Way and tree planting areas should be widened to 5 and 8 feet respectively, as is illustrated in Figure 3.C.47.

Interim Recommendations: The existing “Front Room” restaurant north of the Ferry Building has a long-term lease, and when the Festival Green can be expanded into this area, as mentioned above, is not certain. In order to ensure that the pedestrian environment along the restaurant’s parking lot is improved, the following interim streetscape and sidewalk design recommendations should be considered.

Improvements to the sidewalk are limited by the minimal available right-of-way in this location. Figure 3.C.48 illustrates how a significant improvement over the existing conditions can be achieved by placing trees in tree wells fitted with tree grates and by placing a 3.5 feet-high landscape screen (hedge) between parking lot and sidewalk.

**East Side of Mare Island Way along Festival Green to Georgia Street**

Figure 3.C.49 illustrates how Mare Island Way interfaces with the Festival Green north of Georgia Street. The addition of pedestrian-scale Downtown lights and banners to the Waterfront street lights is critical to the improvement of existing conditions. The row of Downtown fixtures along the sidewalk will demarcate the edge of the green along Mare Island Way.

A 29-foot setback of active open space uses from the face of curb along Mare Island Way should be observed according to requirements contained in the Noise Element of Vallejo’s General Plan (See Figure 2.C.2 in *Chapter II Unifying Elements and Linkages*).

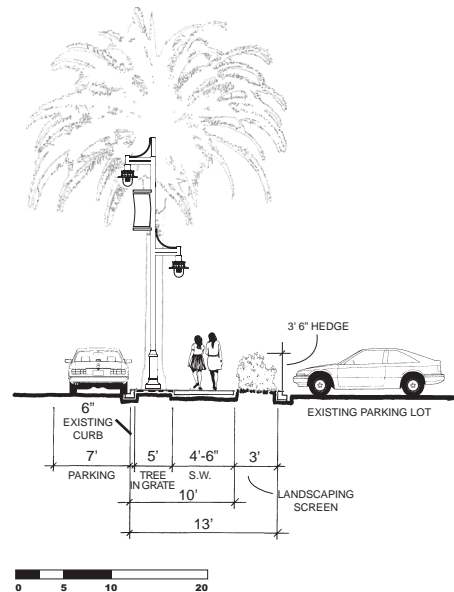

Figure 3.C.48: Partial Section of Mare Island Way at Restaurant Parking Lot (interim recommendations) ④

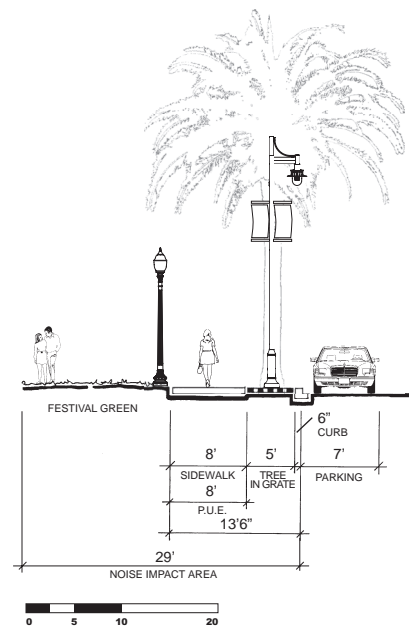

Figure 3.C.49: Partial Section of East side of Mare Island Way at Festival Green ⑤

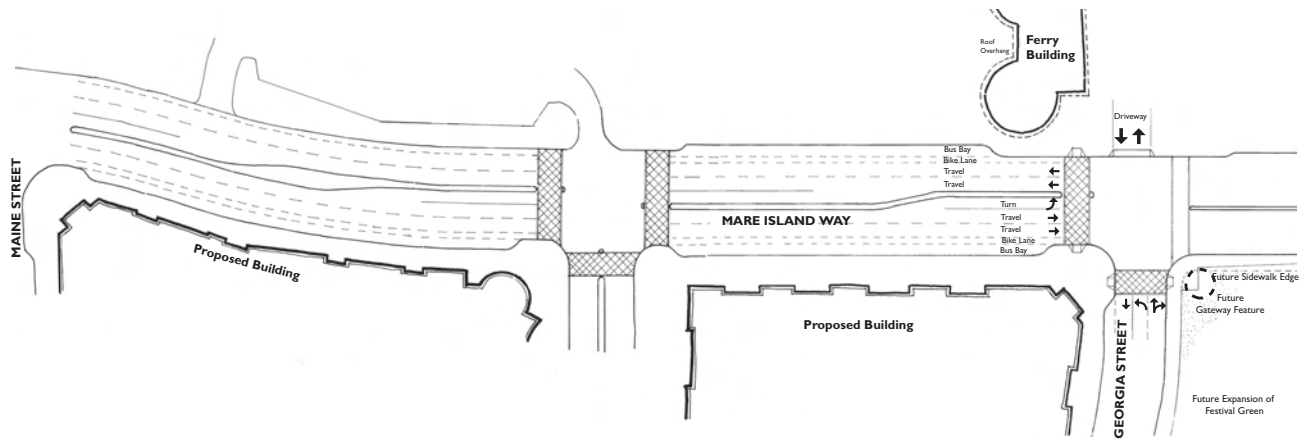

Figure 3.C.50: Mare Island Way between Georgia Street and Maine Street

### **Mare Island Way between Georgia Street and Maine Street**

The configuration of sidewalks and crosswalks between and at the intersection of Georgia Street and Mare Island Way in the north and Maine Street and Mare Island Way in the south, are critical given the high level of pedestrian activity in the area and the extent to which pedestrian activity will increase in the future. It is at these two intersections and along this block, where links to and from the Ferry Terminal, regional and local buses, waterfront open spaces, and retail and civic uses converge.

To successfully implement the envisioned connection of the Downtown to the Vallejo Waterfront along Georgia Street it is essential that functional and safe crosswalks across Mare Island Way be provided which visually tie in with future improvements on the Waterfront side of the street. In addition, the Design Guidelines propose some adjustments to the existing curbs and striping on Mare Island Way between the Georgia Street intersection and the intersection with Maine Street which facilitate improved pedestrian crossings of Mare Island Way (Figure 3.C.50).

### **Between Georgia Street and Entry to Parking Garage**

The cross-section for the segment between Georgia Street and Maine is illustrated in Figure 3.C.51. Benefits of this section include:

- The shortening of the pedestrian crossing distance through the use of curb extensions (bulb-outs) on both sides of Mare Island Way at pedestrian crosswalks; (the final geometric design and feasibility of curb extension from a traffic flow perspective will be determined during the design development phase of future street improvements)
- The crosswalk on the south side of the intersection should be 20 feet wide to provide sufficient space for larger crowds crossing at times when departures or arrival of ferries require the accommodation of larger pedestrian volumes;
- The creation of a pedestrian refuge at the now 4-foot wide median allowing those who do not make it across the entire street on one “signal cycle” to wait safely for the next pedestrian signal;
- Pedestrian countdown signals that indicate the remaining pedestrian signal “green time” should be provided for all directions of travel at this intersection;



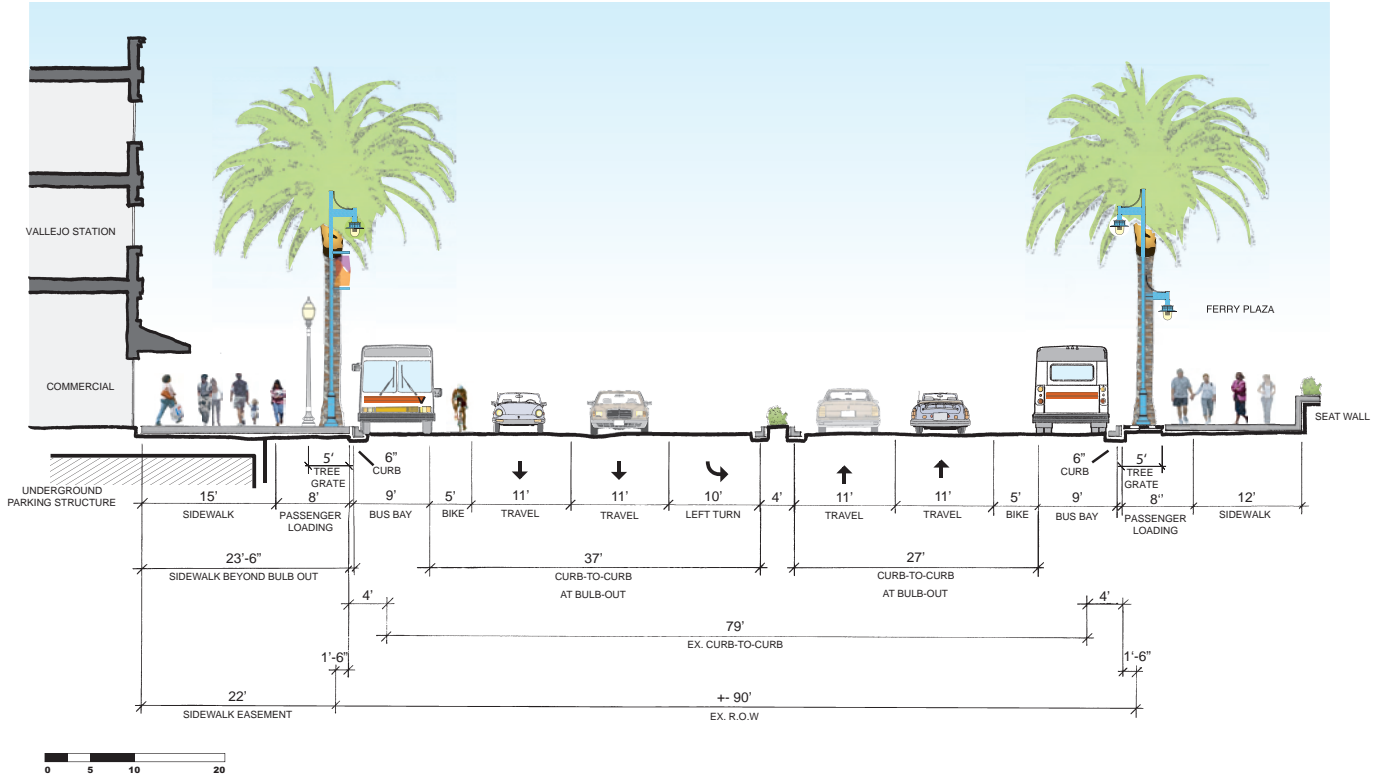

Figure 3.C.51: Section of Mare Island Way at Ferry Plaza (6)

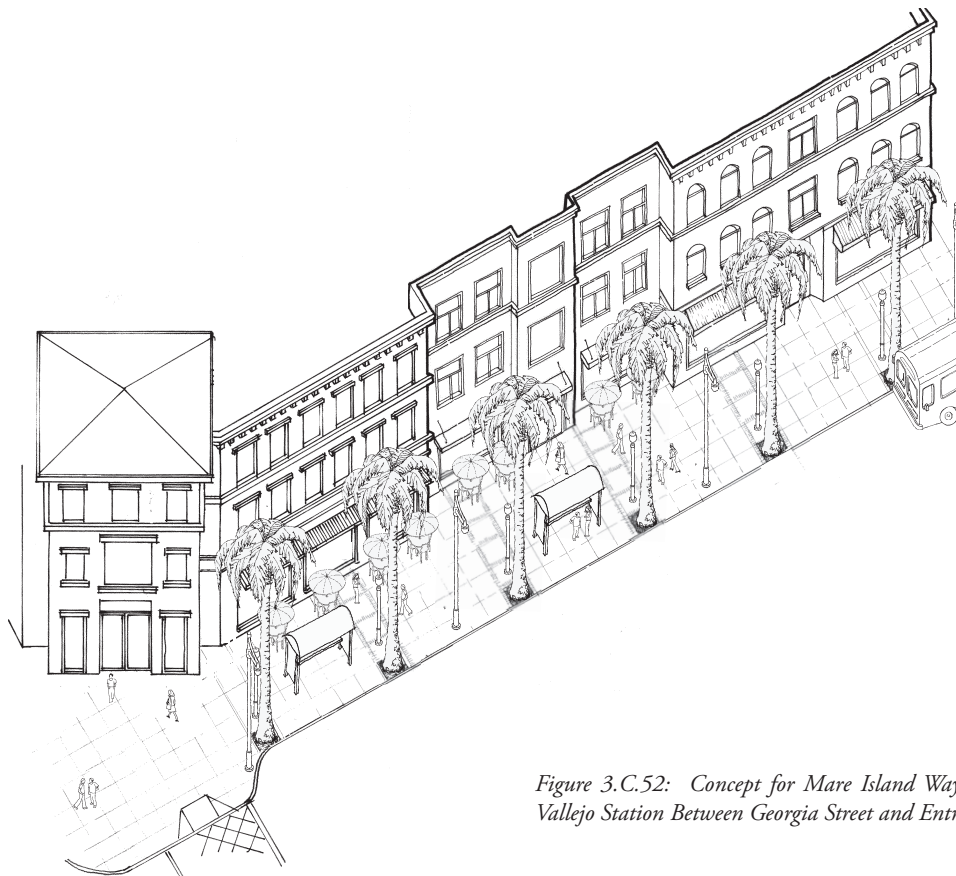

Figure 3.C.52: Concept for Mare Island Way Streetscape Along Vallejo Station Between Georgia Street and Entry to Ferry Parking



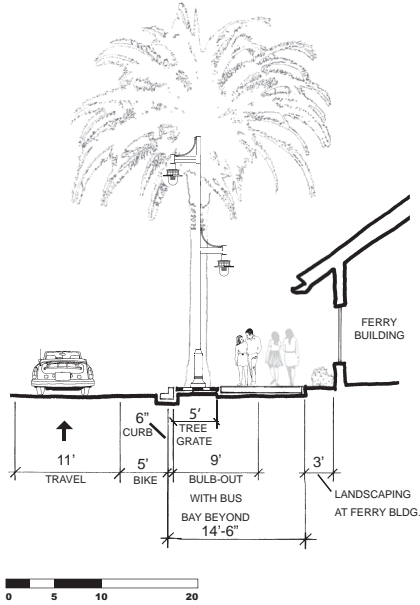

Figure 3.C.53: Section of Mare Island Way at Ferry Building ⑥



Figure 3.C.54: Crosswalk Design for Mare Island Way at Georgia Street

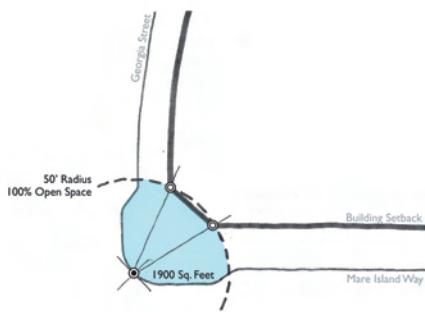

Figure 3.C.55: Corner Plaza Diagram, Mare Island Way & Georgia Street

- The surface of the Mare Island Way crosswalks should be given an artistic treatment that ties in with the design theme of future improvements around the Ferry Building and plaza, and the Waterfront Promenade in this area. This will enhance the visual integration of the Festival Green on one side of the street and the Promenade as well as open spaces on the Waterfront side;
- The integration of bicycle lanes which can be connected to those already existing farther north on Mare Island Way;
- Generous sidewalk space along the Vallejo Station frontage, where a mix of pedestrian activities needs to be accommodated, such as the boarding and alighting of bus riders, potential outdoor seating, access to storefront entries, window shopping, and people walking to and from Vallejo Station’s Paseo as well as Georgia Street Extension and destinations in the Downtown;
- A clear definition of bus stop locations along bus bays on either side of the street.

In addition, the curb extension on the east side of the street creates additional space in front of the anchor building at the southeast corner of Georgia Street and Mare Island Way, which can be used to accommodate potential outdoor seating, bicycle racks, newspaper racks, and other streetscape elements that lend further prominence to this most important site. A building setback at this corner shall be provided to create a public open space area of no less than 1,900 square feet (measured to include the area between the curb of Georgia Street and Mare Island Way and the façade of the building), which may include outdoor seating (See Figure 3.C.55).

The design of the Georgia Street/Mare Island Way intersection and its crossings is an integral part of the reconfiguration of Mare Island Way in this location (See Figure 3.C.54). As these crossings are a further extension of Georgia Street, their design is further described in Section III.C.2.2.1.A Georgia Street Extension.

It should be noted that by maintaining the eastern curb of the existing median, the proposed reconfiguration avoids the need for adjustments in the street’s crown and therefore larger changes to the existing storm drainage system. Vehicular traffic will be unaffected by the proposed changes.

### South of Entry to Ferry Parking to Maine Street

The functional requirements for the proposed reconfiguration of Mare Island Way between the driveway into the ferry parking garage and the Maine Street intersection do not include the accommodation of bus bays, as current transit plans do not envision the need for buses to stop in this area. Instead, on-street parking is provided in front of potential future retail uses along the building frontage on the east side of the street (See Figure 3.C.56). This parking provides convenience to shoppers wanting to stop for a quick errand, for visitors to the residential uses in Vallejo Station, and others needing a place to park for a short period of time. The sidewalks along this part of the block are, with 18.5 feet, still generous but reduced in width as compared to the segment north of the ferry garage driveway. This reduction is based on the lesser volumes of pedestrian activity expected to occur along this portion of Mare Island Way.

On the west side of the street the 15.5-foot wide sidewalk with trees in tree wells is separated from the adjacent parking lot by a landscaping strip of varying width. This Guideline is provided as it is expected that this parking will continue to be used into the future for kiss-and-ride activities related to the ferry. The sidewalk is adequately sized to provide accommodation of pedestrians traveling to the Maine Street intersection on this side of Mare Island Way.

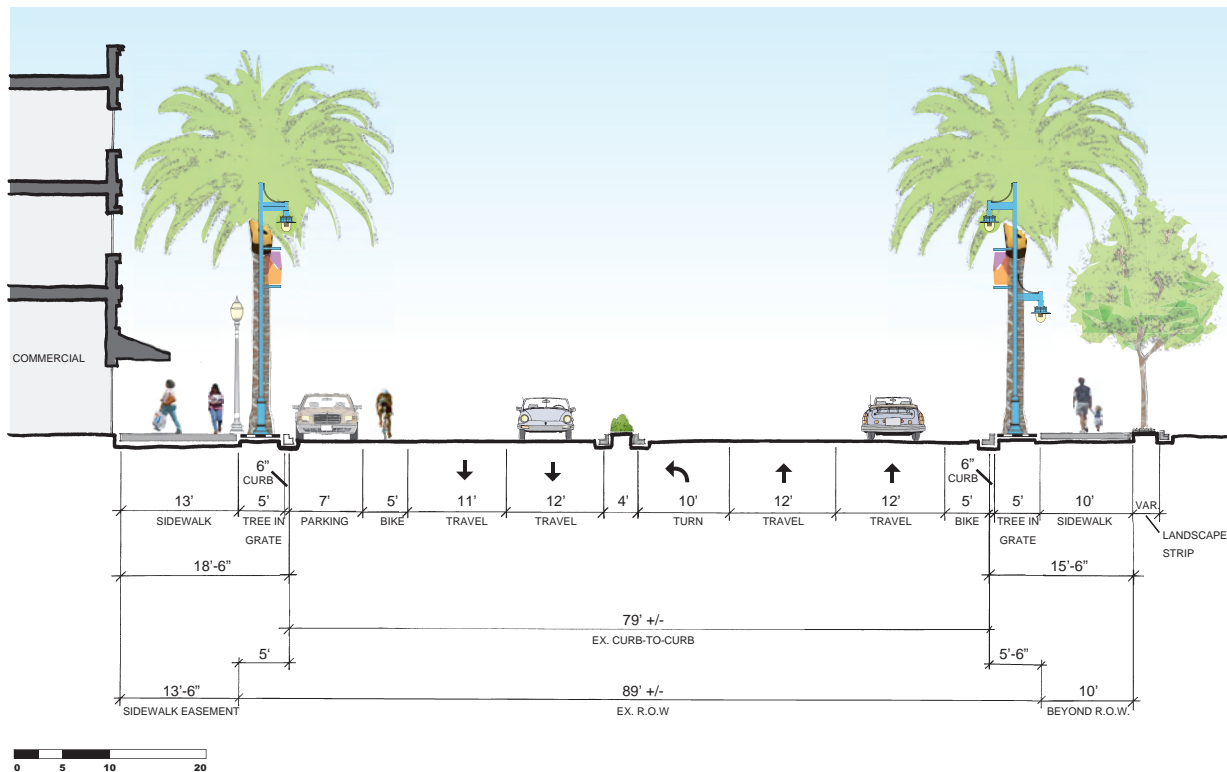

Figure 3.C.56: Section of Mare Island Way South of Entry to Ferry Parking ⑦

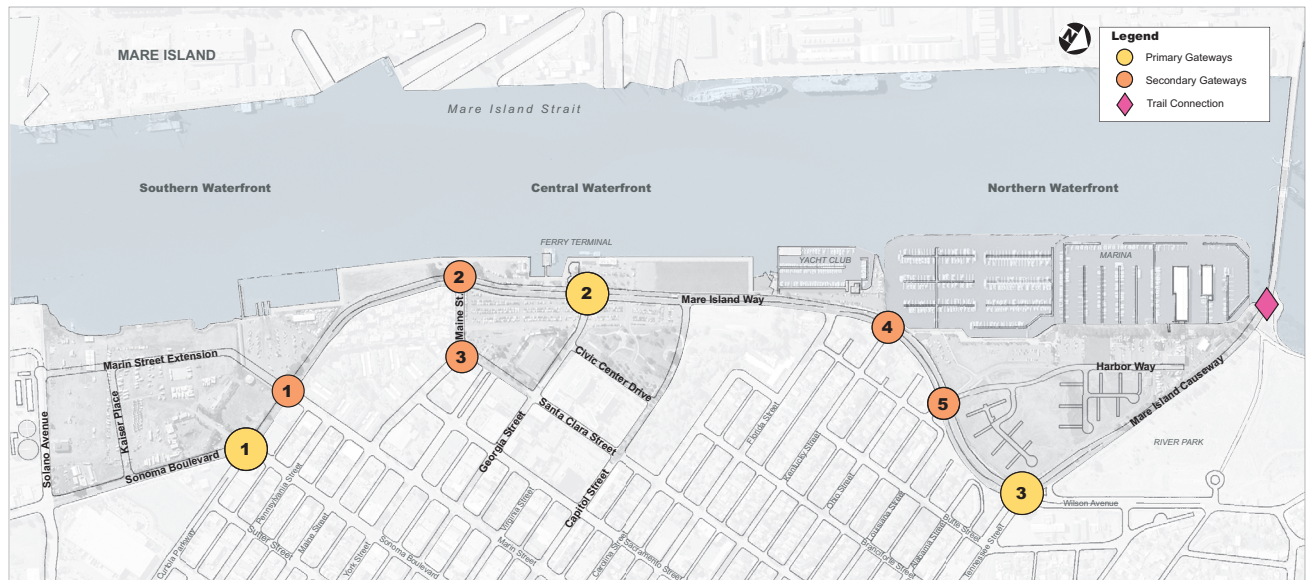

Figure 3.C.57: Diagram of Primary and Secondary Gateways

## 2.3 Gateways

### 2.3.1 Primary Gateway

The primary gateway within the Central Waterfront is located at the Georgia Street and Mare Island Way Intersection. This gateway needs no special gateway treatments in the public realm. The combination of the major public open spaces of the Festival Green at the northeast corner, the expansion area of the Festival Green on the waterfront side of the intersection, the adjacency of the Ferry Terminal building, and the special treatment of the crosswalks and bulb-outs at the intersection, along with the high-level of pedestrian activity in the area will do much to make this gateway a memorable place.

This is the one primary gateway that can be particularly enhanced by the design of adjacent private development. The new building that will be constructed as part of Vallejo Station at the southeast corner of the intersection needs to be designed and have ground-level activity that enhances the gateway as a memorable and special place. The Guidelines for this location will work to achieve this goal by recommending a landmark architectural treatment of the building’s corner and by encouraging the development of ground-floor retail or restaurant commercial use that opens onto the adjacent sidewalk and corner bulb-out.

### 2.3.2 Secondary Gateways

The Secondary Gateways in the Central Waterfront are located at the intersections of Mare Island Way and Maine Street and Maine Street and Santa Clara. The importance of these gateways is set by their proximity to the Bus Transfer Center at Santa Clara. Since this is a drop off point for bus riders coming into the area, these gateways should visually signal the connection along Maine Street between the Bus Transfer Center and the Waterfront. Use of streetscape, landscaping, or built landmarks is recommended for marking the secondary gateways to the Waterfront.

### 3. Private Realm Guidelines

The Central Waterfront extends Downtown Vallejo to the Waterfront Promenade and Parks, and Vallejo's Ferry Terminal. The form of development in the area will be urban in character and activity, with a high level of interaction between the District's streets and open spaces and the buildings that front onto them. This section provides Guidelines for the design of building orientation, frontages, massing, scale and articulation. It describes the design concepts and Guidelines that apply to development unique to the Central Waterfront.

#### 3.1 Site Design and Building Orientation

The Central Waterfront District will see the greatest number of pedestrians due to adjacency to Downtown Vallejo, many public transit linkages and civic open spaces. The District is also similar in density, as well as character, to the Downtown. Therefore, it is critical that the relationship of buildings to public streets and open space strengthen these linkages with supportive site design and building orientation that activates the area creating a comfortable and attractive place for pedestrians. These Guidelines describe the relationship between the buildings in the Central Waterfront and its public streets and open space.

##### 3.1.1 Relationship of Buildings to Streets and Open Spaces

Building frontages in the Central Waterfront District will directly connect to the public realm and define a continuous building façade, just as buildings relate to the public realm in Downtown Vallejo. When buildings form a continuous frontage to public spaces, they provide a sense of enclosure and visual interest; the buildings engage the passer-by and create a comfortable pedestrian-oriented street environment. The increased activity and visual interest associated with continuous building frontages also gives the perception of a shorter walking distance for pedestrians. In contrast, stretches of streets fronted by parking lots, blank façades, or ornamental landscaping within deep setbacks, create spaces that offer little interest and activity for pedestrians. Maximizing active building frontages help make walking a more attractive mode of transportation.

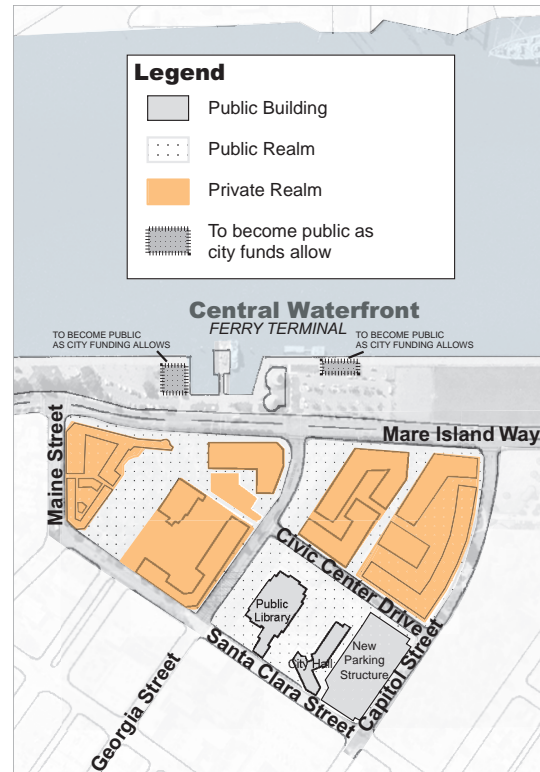

Figure 3.C.58: Vallejo Station Public and Private Realm Diagram



The architecture in the Central Waterfront must be sensitive to the pedestrian scale and the nature of the Waterfront experience. People arriving on the ferry, walking, or driving in from the surrounding areas should see highly articulated and well-defined architecture spanning the Mare Island Way street frontage from Capitol Street to Maine Street. Georgia Street is the retail commercial spine of the downtown and special care should be taken in defining the architectural treatment of this gateway to give it the emphasis it needs while maintaining an inviting and attractive appeal to the pedestrian.

### 3.1.1.A Building Design

1. Buildings should create a well-defined, visually interesting, and continuous building wall with few interruptions from parking lots, driveways, and inactive open spaces and landscape areas.
2. In order to support the pedestrian-oriented environment within the Central Waterfront District, building frontages onto streets and open spaces should be maximized, similar to those existing in the Downtown (Figure 3.C.59). For Vallejo Station (the area within the block defined by Mare Island Way, Georgia Street, Santa Clara Street, and Maine Street) the minimum building frontage should be 90%, of which 20% may be plaza space. The drive into the ferry parking structure should be used in making this calculation. Other streets in the Central Waterfront District should have a minimum building frontage of 85% with the exception of the “civic block” including City Hall and the Public Library.



Figure 3.C.59: A Well-Defined Building Wall.

### 3.1.1.B Building Frontage

1. To the greatest degree possible, active uses similar to those fronting onto Georgia Street and other Downtown streets should occupy the ground-floor directly adjacent to the Festival Green. Uses that can activate and interact with the open space such as retail, restaurants and cafes are preferred, however, hotel and conference center lobbies may be included as part of the frontage. Upper story uses may include hotel rooms, other conference facilities, residential uses, or parking garages (See *Section III.C.3.1.6 Outdoor Recreation, Dining and Display* for additional Guidelines).
2. The frontage at Dr. Martin Luther King, Jr. Unity Plaza should activate the plaza during the day and



into the night. This may be done through the retrofit or reconstruction of the Public Library or through new construction containing civic or commercial uses. If retrofit of the library occurs, efforts should be made to create a more transparent frontage. Interior uses could be redesigned to allow the front entrance, lobby and check out area to front directly onto the plaza. In addition, window walls should dominate all floors.

3. Where residential and/or live/work uses front onto streets and open spaces, such as the Paseo Park, Paseo through residential, Civic Center Drive, Capitol Street, Mare Island Way, Maine Street, Santa Clara Street, and, Festival Green, the elements of such uses that require less privacy or are semi-public should front onto these spaces. These elements include porches, stoops to individual unit entries, lobbies to upper story units, living rooms, and dining rooms, and the work portions of live/work units (Figure 3.C.60).
4. The frontages of Georgia Street and Mare Island Way from Capitol to the ferry parking garage driveway should be considered as prime space for commercial uses that can take the greatest advantage of a high degree of pedestrian traffic (Figure 3.C.61). The sidewalks for these streets should be fronted by uses that activate them at the ground-floor such as storefronts, restaurants, cafes, the work portion of live/work units, hotel, conference center and office lobbies, and the most active spaces within offices such as the front lobby. For ground-floor retail, active storefronts or display areas should turn the corner for at least 50% of the façade along the Ferry parking garage driveway in order to activate this important pedestrian route.
5. Parking structures should include active ground-floor uses, such as retail, to create a pedestrian-supportive interface with the surrounding sidewalk, particularly on more active street frontages such as Georgia Street, Santa Clara Street, and Mare Island Way (Figure 3.C.62). On more minor streets, parking structures should, at a minimum, be buffered with landscaping if active ground-floor uses are impractical. Façades should be designed with equal attention to form and articulation as other buildings within the Central Waterfront. Parking structures may also be built to include ground-floor retail in the future with minor retrofitting.



Figure 3.C.60: Ground-floor Residential Entries in an Urban Environment.



Figure 3.C.61: The corner of Georgia Street and Mare Island Way should offer a dynamic and lively place that attracts people



Figure 3.C.62: Parking garages can be designed to support a high-quality pedestrian environment

6. Mixed-use buildings with first-floor retail or live/work fronting onto Georgia Street or Mare Island Way should be treated as follows: A 12-foot (min.) deep, continuous arcade should be incorporated into the building along the first floor frontage of the building. The arcade should extend for the entire length of the retail frontage and should be accessed from the sidewalk on Georgia Street or Mare Island Way by periodic sets of stairs. Any portion of the exposed parking garage wall should be screened with landscaping or be treated with materials and detailing to provide interest and human scale (See *Section III. C.3.1.4 Off-Street Parking and Drop-off Areas* for additional Guidelines on Parking Structures). Site planning of the development and parking garage should minimize the exposure of parking garage edges on all adjacent streets to the greatest extent feasible.



Figure 3.C.63: Frequent store entries activate a street frontage.

### 3.1.2 Building Entries and Access

Main entrances fronting sidewalks, pedestrian routes and public open spaces should emphasize walking access for those who arrive at the Ferry Terminal, who walk from the Downtown or surrounding neighborhoods, or who have parked once in the Waterfront or Downtown and walk between destinations in the area. Fronting primary entrances directly onto publicly accessible spaces will create a strong relationship between the private realm and the public realm, and will provide continuity with the downtown streets. This will encourage pedestrians to filter through the District between the Downtown and the Waterfront (Figure 3.C.63).

#### 3.1.2.A Entry Orientation

1. Entries should be encouraged to open onto the Festival Green and Dr. Martin Luther King, Jr. Unity Plaza in order to relate adjacent uses to these spaces and contribute to activity.
2. A primary entrance at or close to the corner of Georgia and Mare Island Way is strongly encouraged in order to activate and provide a prominent architectural feature at this important intersection.

3.1.2.B Entry Spacing

1. Entry spacing for various uses should follow the Guidelines below given for predominant ground-floor use. Entries for upper floor may count towards satisfying this Guideline (Figure 3.C.64).

Land Use	Maximum Distance (on center)	Minimum Average Distance (on center)
Residential	42 feet	36 feet
Retail or Live/Work	60 feet	48 feet
Office	120 feet	None

Table 3.C.1: Entry Spacing Guidelines

2. Pedestrian entries to parking structures should be located at each corner of the structure. Parking structures greater than 90 linear feet should have more than one entry.



Figure 3.C.64: Table 3.C.1 provides Guidelines that allow flexibility in the location of entrances for various types of uses.





Figure 3.C.65: Recessed building entries commonly found in Vallejo's Downtown provide display or seating space as well as clear space for pedestrians along sidewalks.



Figure 3.C.66: Example of a Well-Designed Entry For a Modern Building Style.

### 3.1.2.C Commercial Retail Entries

1. Every retail establishment and live/work unit should have its own entry directly from or connecting to a publicly accessible sidewalk, walkway, or plaza space, such as the Paseo Park.
2. Entries to retail spaces, restaurants, and cafes should be recessed to increase circulation space available to pedestrians who are entering and exiting the business (See Figure 3.C.65 and 3.C.66).

### 3.1.2.D Residential Entries

1. Porches and stoops should have a clear space of no less than 5 to 6 feet in depth and 5 to 6 feet in width.
2. Lobby entries to upper-floor units and units within the interior of the development should be oriented toward adjacent streets or the paseos. Where buildings and lobbies are located interior to residential blocks, these should be oriented towards the primary pedestrian circulation system within the block, and whenever feasible, be visible from streets or paseos.

### 3.1.3 Visibility of Ground Floor Activity

Visibility of ground floor activity is particularly important within the Central Waterfront where greater pedestrian activity will occur throughout the day and into the evening. A high level of visibility between the public and private realms will encourage a dynamic environment and afford a greater sense of security. (See Section III.A. 2.2.3 *Visibility of Ground Floor Activity*).

### 3.1.4 Off-Street Parking and Drop-off Areas

1. Parking requirements within the Central Waterfront should be minimized to account for shared parking and transit accessibility.

#### 3.1.4.A Parking Structures

As stated elsewhere in these Guidelines (*III.C.3.1.1.B: Relationship of Buildings to Streets and Open Spaces, Guideline #5*) parking structures should include active ground-level uses. A design as shown in Figure 3.C.67 should be avoided. Situations may arise where this is not possible given parcel sizes, topography, and the need to provide an extensive amount of parking for ferry riders

within the Central Waterfront. The following Guidelines will help to create a high-quality and pedestrian-friendly environment in locations where parking structures are exposed to the public realm of the Central Waterfront.

1. Parking structures that front onto a sidewalk, street or public open space should be designed to reflect the architecture of surrounding buildings as well as those of the Downtown.
2. The exterior of parking structures that are visible from public streets and open spaces should be designed to have façades that are articulated as standard buildings with openings similar to windows and detailing reflecting floor levels and other details that would be expected in the design of any residential or commercial building (Figure 3.C.68).
3. Elevators and stairs should be designed to activate and articulate the façade of parking garages with balconies and railings, providing opportunities to glimpse pedestrian activity within the structure.
4. Visibility of any sloping floors and long horizontal openings should be avoided.
5. Where ground-floor parking and podium parking must abut sidewalks, parking façades should incorporate a high level of architectural detailing and articulation on façades and screening elements.
6. At a minimum, screening should include landscaping, landscaped planters, decorative architectural detailing such as metal and grill work, or changes in materials and colors. Planters that are too tall should be avoided (Figure 3.C.69). (See *III.C.3.2.2.A: Architectural Detailing and Ornamentation* for additional landscape planter Guidelines).

### 3.1.5 Off-Street Loading and Service Access

Due to the density of building within the Central Waterfront, the location and design of off-street loading and service areas will be a critical feature to consider such that they do not detract from the pedestrian aesthetic that will need to be established in this District. In addition to the Guidelines that are outlined in *Section III.A.2.2.6 Off-Street Loading and Service Access*, the following Guidelines are applicable in the Central Waterfront District.



*Figure 3.C.67: (Example of Poor Design) Excessive blank walls along a parking garage creates an uninviting and inactive street frontage and should be avoided.*



*Figure 3.C.68: A parking structure that accommodates retail at the ground floor and provides interest along the facades creates a much friendlier and lively street frontage.*



*Figure 3.C.69: (Example of Poor Design) Planters should not exceed a comfortable pedestrian-scaled height. These are too tall.*



1. Loading and service areas for such uses as a hotel, offices, and conference center should be consolidated and located within the interior of the block. Access should be either from Santa Clara Street or Georgia Street into the parking lot for Parcel L2.
2. Loading and service areas for the office/retail parcel in the Vallejo Station block should be located away from Georgia Street and towards the interior of the block.
3. Loading and service areas for the retail/live-work and residential buildings in the Vallejo Station block should be located within the building envelope. Short-term loading and service may happen within the Paseo Park during off-peak hours.
4. Service areas for residential uses should be located within the parking structure serving the units.

### 3.1.6 Outdoor Recreation, Dining and Display

Uses that activate sidewalks and open spaces are desirable along building frontages in the Central Waterfront, particularly if they can activate these spaces by “spilling out” from the building to create a dynamic pedestrian realm. Typically, these include outdoor dining and display (Figure 3.C.70). Semi-private uses such as hotel pool facilities and private dining that is not open to the public are less desirable since they typically require greater visual and physical separation from public spaces. If semi-private uses must front onto public spaces, they should be carefully designed to avoid creating uninviting frontages and instead, create a positive visual relationship between activities.

1. Private and semi-private outdoor and recreational uses, such as hotel and pool facilities and plazas where private events will be held, should not be located adjacent to public sidewalks and open spaces. Such uses are often walled off, creating an uninviting frontage. Instead, these facilities should be located within the interior of the block.
2. If semi-private uses associated with the hotel and conference center must be located next to a sidewalk or public open space, they should be designed and buffered in a way that adds to the quality and activity level of the public spaces.



*Figure 3.C.70: Open railings and glass awnings create a transition between sidewalk and the building interior, yet still create an inviting street frontage.*

3. Such uses will require more separation along their more public frontage. Landscaping and/or a visually screening fence or wall, up to 6 feet tall, may be used. However, these uses should mitigate the need for privacy with the need to create an inviting frontage, therefore, some visual transparency should be maintained and a high level of articulation should be used. Fences or walls should match the design of the primary building they are associated with.
4. **Storefront Expansion Zone:** Subject to approval by both the Development Services and the Public Works Departments, retailers in the Central Waterfront District may use sidewalks as part of their presence on the street. A storefront expansion zone of approximately 2 feet wide may be identified along the building façades that will be available for retailers to extend their merchandising past the building façade plane. This space can be occupied by constructed projections, such as bay windows or a series of doors that open to the sidewalk during warmer months. Other elements may include benches or pots with flowers or shrubbery. These elements should reflect the quality and identity of the retailer or restaurant but should not obstruct pedestrian flow.

### 3.2 Human Scale and Building Contribution to the Public Realm

Buildings within the Central Waterfront should take their architectural cues from, though not directly mimic, buildings within Downtown Vallejo in order to physically extend the Downtown and its pedestrian-friendly qualities to the Waterfront. That is, massing, height, proportions, rooflines, composition, rhythm, fenestration, and other architectural features should be similar in quality of design and detail to that found in the architecturally significant buildings of Downtown Vallejo (Figure 3.C.71).

Achieving human scale of buildings is not related to the height of a building, but more so to how the height and massing of the building are modulated and the detail of the architectural design of the building. Figure 3.C.74 illustrates how the visual appearance of the 7-story building (at right) can be broken down through stepping back its upper floors. Another key factor in achieving human scale is the use of façade detailing that includes smaller, human scale building details and building materials that provide interest if viewed up close at pedestrian level or from



*Figure 3.C.71: Human -scale facade design engages the pedestrian's eye, strengthening their relationship to the pedestrian.*

across the street. Figure 3.C.81 illustrates how the addition of Juliet Balconies adds to the interest of the façade of this building and reduces its apparent height while providing an element that has a recognizable scale to pedestrians walking along the street.

### 3.2.1 Building Form

The significant architectural buildings within Downtown Vallejo are relatively complex in detail, yet fairly simple in form. Although their form and articulation can create a dynamic façade that is appealing to pedestrians, they also act as a backdrop to activity on the street and frame streets and views without overpowering the landscape with overly complex massing. Their relative consistency in height, façade, roof elements and massing all contribute to creating a building that is orderly and comfortable. New development should also be of a scale that can be easily comprehended by a pedestrian. This requires building form and massing that provides a comfortable balance of enclosure and openness to frame vistas to key views of Mare Island, the Strait, Downtown and surrounding neighborhoods. The following Guidelines define building form for new development that is compatible with the Downtown.

#### 3.2.1.A Scale of Building Massing and Height Guidelines

The Vallejo Station and other new buildings in the Central Waterfront District have the unique opportunity to create a strong linkage between the Waterfront and the development across the Mare Island Strait. The height and massing of buildings should contribute to bridging the Waterfront and the Downtown (with the new development occurring there) and take advantage of the topography in the area, to maximize the spectacular views across the Strait and to Mare Island. In general, massing of buildings on the Vallejo Station site should relate to what is found in the Downtown in order to maintain continuity and the sense of pedestrian scale.

1. The corner of Georgia Street and Mare Island Way should be defined by a building that creates a well-defined gateway and becomes a landmark feature as visitors arrive by various modes of transportation. For this reason, defining this corner with a 3-story building that still meets the height limit set by the Planned Development Master Plan (PMDP) height



Figure 3.C.72: Example of Building Massing and Scale That Provides Definition to the Corner of Georgia Street and Mare Island Way

of 45 feet is strongly encouraged at this intersection (See photo simulation of a sample building in Figure 3.C.72).

2. Single buildings with long street frontages greater than 72 linear feet should be designed as multiple façades to relate to the scale of surrounding downtown buildings. However, multiple façades should also reflect changes in interior usage. For example, façade changes should occur with changes in storefronts within one building (Figure 3.C.73).
3. Articulation and terracing of building massing shall be the primary ways to achieve the necessary architectural variation in massing. Emphasis shall be placed on designing highly articulated (both horizontally and vertically) and well-detailed buildings fronting all streets in the Central Waterfront area. The primary goal of terracing and articulation is to avoid blank, minimally articulated building walls fronting Mare Island Way, Georgia Street, Santa Clara Street, and Maine Street and to avoid building façades on Mare Island Way that have only one continuous minimum setback without terracing of the building massing. This articulation shall apply to all levels fronting on all streets in the Central Waterfront area, regardless of building height. The articulation and terracing in the building massing should be large enough to allow the residential or office uses on the upper floors to use this space as an outdoor terrace when appropriate for the associated use, in order to increase activity along these important building façades. Curvilinear buildings are not appropriate in the Central Waterfront area, although curvilinear design features such as turrets and window details are acceptable.



*Figure 3.C.73: The facades of single buildings can be broken up to create a more dynamic street frontage with multiple facade designs, colors and materials.*



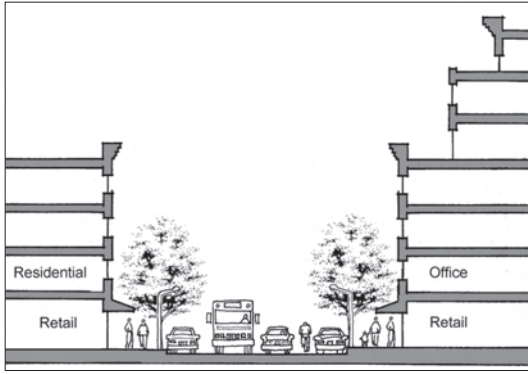

Figure 3.C.74: Taller buildings should be designed to step back or modulated in order to create compatible building forms on either side of a street.

### Transition in Scale from Downtown to Waterfront

A central goal for development in the Central Waterfront District is to link the Waterfront with the Downtown. The Downtown Specific Plan defines a maximum height limit of 7 stories and 85 feet which is higher than allowed in the Central Waterfront. In order to reinforce the relationship between the Downtown and the Waterfront it is important to provide an appropriate transition in scale and building height between these areas. Using a preliminary site plan as a basis, the axonometric in Figure 3.C.75 illustrates an approach to building massing supported by the Guidelines of this section.

1. Building massing and articulation should respond to the topography of the site and street by stepping and varying heights. This will create a massing that reflects existing site characteristics and maintain an appropriate scale as people move through the Central Waterfront.
2. Buildings should be taller in height along Santa Clara Street and step down by 1 to 2 stories towards the Waterfront in order to be compatible with buildings heights proposed across Santa Clara Street, as well as maximize views from residential units to the Waterfront, the Strait and Mare Island (Figure 3.C.75).

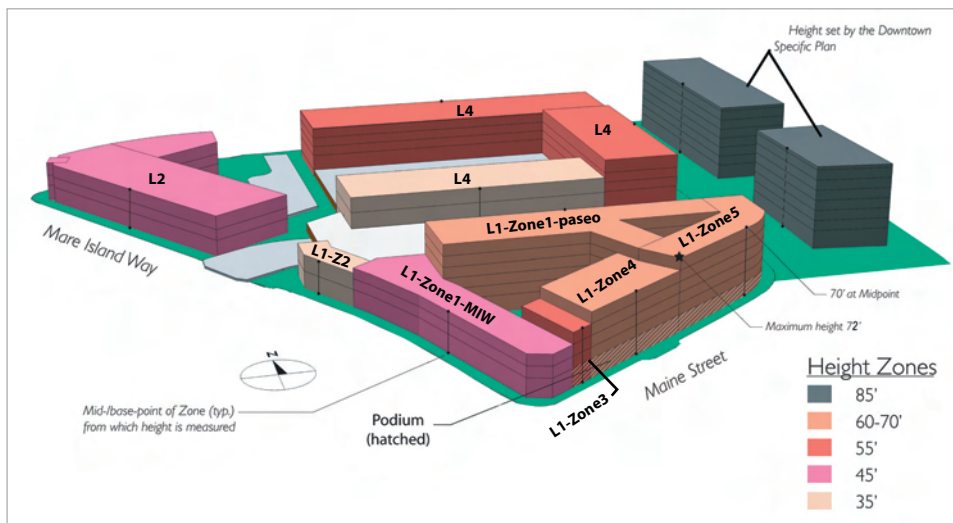

Figure 3.C.75: Building Massing and Height Diagram for Vallejo Station



3. Building massing and scale should be compatible with existing buildings and the building standards for sites across the street from the building that is being designed, in order to harmonize frontages on both sides of the street. Taller buildings should be modulated or designed to step back where they exceed the height of buildings across the street and adjacent buildings. This setback should happen only above the third floor or higher of the taller building. This can be achieved by stepping back buildings façades, changing rooflines and/or incorporating terrace balconies (See Figure 3.C.74).

### 3.2.1.B Façade Scale and Variation Guidelines

Variations in façade articulation should be compatible with the rhythm and scale of the existing, architecturally significant buildings in the Downtown and as specified within the *Downtown Vallejo Specific Plan* and accompanying Guidelines, particularly for new development along Georgia Street, Santa Clara Street and the blocks of Mare Island Way between Georgia and Maine Streets. This will reinforce the notion of connecting the Downtown with the Waterfront and the Ferry Building as a main gateway into the center of the city (Figure 3.C.76).

#### *Integrate into the Overall Fabric*

When viewed individually, the buildings of Downtown Vallejo may be significant in their architectural style and detailing, yet as part of the whole they act as a backdrop that provides enclosure and a level of comfort in their consistency. That is, they contribute to the aesthetic environment without fighting for center stage as landmark buildings would.

1. Buildings should take into account the urban environment of the surrounding Downtown. They should integrate into the overall fabric and should not stand out as landmarks. Rather, landmark buildings should be reserved for significant civic buildings, such as a performing arts center, and buildings associated with City Hall and the Public Library.
2. Buildings should create architectural relationships with surrounding buildings. That is, building heights, massing, form, and façade composition (i.e., fenestration, cornices, rooflines, etc.) should not mimic, but should relate to surrounding buildings.



Figure 3.C.76: New buildings should complement the scale and articulation of adjacent buildings.



Figure 3.C.77: Transom windows emphasize taller ceiling heights at the ground floor.



Figure 3.C.78: Bays, recesses and overhangs break up the building's facade to create a dynamic frontage.



Figure 3.C.79: Facade variation makes Vallejo's Downtown an engaging and memorable place to visit. New buildings, should also provide variety.

### Floor-to-Ceiling Heights

1. Ceiling heights for ground-floor commercial spaces should be similar to those proposed for the downtown area (Figure 3.C.77). This is particularly important along Georgia Street and Santa Clara Street. See *Section III.A.2.3.1.B Façade Scale and Variation Guidelines* for minimum floor-to-ceiling requirements per land use.

### Setbacks and Recesses

1. Building setbacks can vary in order to create a more dynamic street wall. However, setbacks and recesses greater than 5 feet in depth should be reserved for store or lobby entries, outdoor seating, dining, and/or display.
2. Recesses and setbacks less than 5 feet should not span a length greater than one "bay" (approximately 16 to 20 feet) along the building frontage.

### Variations In Building Façade

The larger-scale massing and height of the buildings within the Central Waterfront can be further related to Downtown Vallejo and provide more refinement in terms of the human-scale of the buildings through the use of massing and façade elements, such as bays, recesses, overhanging eaves, etc. that provide interest and scale to the façades of the buildings (Figures 3.C.78 and 3.C.79).

1. Buildings with a frontage greater than 30 feet should make use of bays, recesses, overhangs, and other massing elements to create a human-scaled character to the building. The use of changes in plane as small as 6 to 18 inches in depth can be used in combination with architectural detailing, materials, and color to satisfy this Guideline.

### Corners and Landmark Features

1. The southeastern corner at Mare Island Way and Georgia is an important intersection that acts as a gateway to the city. The building at this intersection should directly address the street corner with a primary entrance, a vertical element such as a tower feature, and/or other building or urban design elements. Elements should be proportioned to account for the average height of the building and the span of the intersection.

2. Corner of Mare Island Way and Festival Green: An active retail use or restaurant should be located here, if feasible, to take advantage of this prominent location. A small plaza should be provided in association with this ground-floor use. As retail continues along the Mare Island Way and Festival Green frontages, ramp or elevator access should be provided to the proposed arcade and continuous walk from this location and designed as an integral part of the plaza.

### **Rooflines**

The Central Waterfront is visually prominent from the Downtown, the Waterfront Promenade and parks, surrounding neighborhoods, Mare Island, and particularly for those who arrive by ferry. As buildings climb up the slopes to Downtown their rooflines should be a distinctive and memorable feature.

1. The rooflines of buildings in the Central Waterfront should reflect the character of the Downtown and the Downtown Specific Plan where buildings are in close proximity to the Downtown.
2. The profile and form of building rooflines may transition to a more distinctive architectural expression moving away from the Downtown towards Mare Island Way.

### **3.2.2 Building Articulation**

The historically significant buildings within Downtown Vallejo are defined by simple forms, but compensate with rich architectural features and the use of quality materials. They provide definition of human-scale and interest, particularly at the street level. This is indicative of buildings that were built when pedestrians were the primary focus when creating places. Buildings within the Central Waterfront will provide continuity by including architectural detailing that responds to a human scale in order to create an environment that will be attractive and interesting.



Figure 3.C.80: Juliet balconies can be found on buildings in Vallejo's Downtown.



Figure 3.C.81: Facades with simple massing are balanced by a series of Juliet balconies that create a human-scaled connection between upper floors and the street.

### 3.2.2.A Architectural Detailing – Scale and Ornamentation

Articulation can create a level of interest for pedestrians that supports an active and transit-oriented environment in the Downtown and Ferry Terminal area.

1. Façade articulation and detail should be in harmony with that of other buildings within the Downtown and the Waterfront. Towards Mare Island Way and the Waterfront Parks and Promenade the architectural style and detailing may take on a more unique characteristic, but should still provide an appropriate human-scale and quality.
2. Elevated planters that act as buffers where podium or structured parking abuts a sidewalk along street frontages should not exceed 4 feet in height and should not be more than 20 feet in length without a change in plane. Planters should not be less than 3 feet nor exceed 8 feet in depth. The planter wall should be well articulated with materials that are complementary to the associated building façade.
3. Juliet Balconies (i.e., balconies with a flush or minimal depth) are encouraged as they strengthen the relationship between activities on upper floors and the public realm (Figures 3.C.80 and 3.C.81). They should have a minimum 8 foot wide door opening connecting the balcony with the interior. This allows the balcony to function as an extension of the room.
4. With the exception of Juliet Balconies, balconies should be a minimum 6 feet clear in depth. Balcony railings should not consist of fully opaque walls. They should be visually permeable with horizontal or vertical railings.

### Building Materials and Finishes

1. Materials selected should create an architectural character in keeping with significant historic buildings in the Downtown and significant regional architectural traditions, relate to the architectural character of adjacent neighborhoods and buildings, and convey a sense of durability.
2. A variety of building finishes and materials are desirable in creating pedestrian-supportive architecture that reflects what is used in the Downtown. Acceptable



façade materials include: tile (ceramic or clay), masonry (stone or brick), stucco and stone cladding. Acceptable materials for architectural details include: pre-cast concrete, wood, cultured stone and green building materials that are of wood type.

3. Other materials that are acceptable, but which should be limited in their use include: higher quality curtain-wall systems that provide shadow lines and scale through the use of mullions that contain relief metal panels, synthetic details finished in stucco and concrete masonry units of varied colors.
4. Acceptable roof materials include any high-quality material such as: slate, concrete or ceramic tile, and standing-seam metal.

### ***Wind and Weather Protection***

1. Consideration of the potential for building massing and form to create a “wind tunnel” effect should be considered and avoided in the design of buildings within the Central Waterfront.
2. Generally speaking, given the height and massing of buildings in the Central Waterfront, and if the buildings implement the Guidelines for building articulation, such as façade variation, bay windows, etc. there should not be a significant wind tunnel effect.
3. Implementation of the streetscape and open space Guidelines will also serve to ameliorate potential wind impacts through the use of trees and the orientation of public gathering and seating locations with a variety of orientations to the prevailing wind direction from the west to southwest.

### ***3.2.3 Transition from Public Realm to Interior Space***

1. A conference center or a hotel lobby should either front directly to the sidewalk of a public street or be fronted by a plaza that creates a public frontage where people feel that they are invited into the space. Plazas should include amenities such as seating, landscaping, lighting and weather protection. Plazas should not be a part of the driveway or drop off area for the hotel.



### 3.2.4 Utilities and Mechanical Equipment

Rooftop utilities will be particularly visible from Mare Island Way and the Waterfront with the increasing height towards the Downtown, which creates even more visible roof area. The rooftops of buildings in the Central Waterfront will also be highly visible from taller buildings allowed in the Downtown. Also, given the layout of the buildings, in particular in the Vallejo Station block, there is little or no “back” for the buildings where outdoor utilities and equipment can be located.

1. Utilities and mechanical equipment should be integrated into the building. Where rooftop utilities and equipment are required they should be screened with building elements including grills that are integrated with the roofline and roof design of the building.

**(Endnotes)**

<sup>1</sup> The City shall delay installation of the planned northern row of parking along the pedestrian Paseo until, in the City’s determination, the conference center or other uses in Parcel L4 (including the conference center) require such additional parking spaces. The City shall be responsible for the costs of installing such future parking spaces. If additional parking spaces prove not to be needed to serve uses on Parcel L4, the City should make improvements to integrate this area into the Paseo Park.

<sup>2</sup> See Section 5.1 Circulation, of the PDMP, regarding required study of the need for connection of Civic Center Drive to Georgia Street.

<sup>3</sup> See footnote 2.

## D. Northern Waterfront District

### 1. District Character and Context

The character of the Northern Waterfront District is, to a great degree, determined by the existing development in the District; including:

- **Development at the Waters Edge:** The existing marinas and Promenade, including the grove of trees along the northern portion of the Promenade (See Figure 3.D.2), determine the visual relationship between the District and the water. The presence of the marinas somewhat limits the visual relationship between the District, Mare Island and the Mare Island Strait, as views are mostly filtered through the masts of the boats in the marinas.
- **Commercial and Industrial Development:** In addition to the existing Harbor Master building there are a variety of commercial and light industrial marine-oriented businesses in the central and northern portions of the District that are accessed off of Harbor Way and served by existing and redeveloped surface parking lots. The character of these developments includes the marine-style design of the Harbor Master's building and other marina structures; the somewhat residential character of the Water Barge Restaurant; and the simple, industrial style of the Vallejo Boatworks, the Coast Guard Station, and other development in the area.
- **Open Space & Parks:** As already mentioned the existing Promenade and grove of trees do much to establish the current character of the District. People from the local community and from farther away do come to this part of the Promenade to stroll and exercise. Visitors often take the Promenade to the north under the Causeway structure to River Park. The existing Jazz Festival Green (See Figure 3.D.4) is used both for casual recreation and picnics, and for special events including the Jazz Festival that currently occurs in this park one weekend a year. These activities could move to the new Promenade Park or Festival Green in the Central Waterfront to link them with the revitalization of Downtown Vallejo and Vallejo Station.

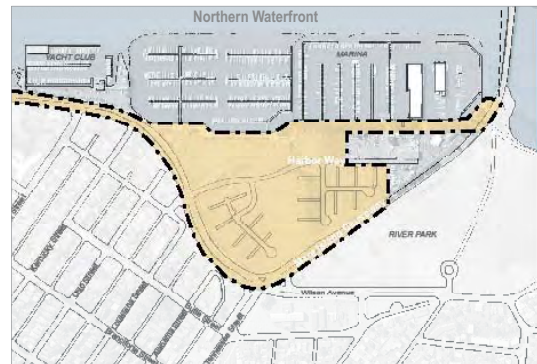

Figure 3.D.1: Northern Waterfront District Location



Figure 3.D.2: Promenade in Eucalyptus Grove



Figure 3.D.3: Mariner's Cove - Proposed Open Spaces, Streets and Development



Figure 3.D.4: View from Promenade Across Jazz Festival Green

The envisioned future character of the Northern Waterfront District will complement the character of much of the development that exists today. The Mariner's Cove proposed project will develop the vacant lands within the Northern Waterfront District with residential, retail and recreational uses to complement the existing Harbor Master and marina uses (See Figure 3.D.3). Mariner's Cove will include tree-lined streets, two large parks, and other landscaped areas, as well as provide improvements to the Waterfront Promenade. Harbor Way will be realigned toward the east in order to create more area for the Promenade Park, which will provide new active recreation and picnicking opportunities with direct access to the Waterfront Promenade and views of the adjacent marinas.

East of Harbor Way, Mariner's Cove will be characterized by the new 4.0 acre Wetland Park, centered between two residential neighborhoods of townhomes arranged around a series of shared open spaces and Northern Waterfront streets. The townhome buildings are complemented by a network of internal landscaped walkways, neighborhood-oriented open spaces, and landscaped buffers around the edges of the site. The future character of areas west of Harbor Way is largely determined by the new 3.5 acre Promenade Park, the retail and restaurant buildings, and the surface parking lots to either side of the park. The potential redesign of the surface parking lots in this sub-area of the District provides parking for both existing and new uses, including parking for the marina. The Guidelines in this section are intended to guide the integration of streets, buildings, parking lots and new-and-existing open spaces, including the Promenade, in a way that mutually enhances marina facilities, parks, the Promenade, and the experience of building occupants along the entire Waterfront.



## 2. Public Realm Guidelines

As discussed in previous public realm sections of the Guidelines, the City will be undertaking a public planning process for the open spaces and parks along the Waterfront. These Guidelines serve to inform that process and provide it with a starting point.

### 2.1 Promenade Guidelines

The Waterfront Promenade will be a key destination not only for the new residents of Mariner's Cove, but will remain so for visitors from adjacent neighborhoods and other parts of Vallejo. While some portions of the existing Promenade will be incorporated in their existing condition into the overall concept for improvements of the Promenade in this District, there are other sections that will require a more extensive enhancement to meet the needs of nearby residents and Vallejo's citizens at large. The Promenade in the Northern Waterfront can be broken down into the following four main segments (See Figure 3.D.5).

1. **Northern Extension:** A currently relatively undeveloped segment from the Causeway Bridge to the Coast Guard facility;
2. **Allee of Trees:** The allee of trees from the Coast Guard facility to the area south of the Harbor Master building;
3. **Promenade Park Frontage:** The segment south from the Harbor Master building to the location of the proposed new restaurant; and
4. **Mare Island Way Connection:** The segment from the future restaurant to Mare Island Way.

#### Northern Extension

This area of the Promenade is relatively undeveloped with an asphalt path, a fence along the water's edge, informal landscaping along the slope leading up to the Mare Island Causeway and a dirt path under the Causeway to River Park. There are dramatic views from this area back across the Marina and of the Causeway Bridge and Mare Island (Figure 3.D.6). Guidelines for improvements in this area are provided in *Section III.D.2.3.4 Trail Connections* and *Section III.D.2.4 Gateways*.

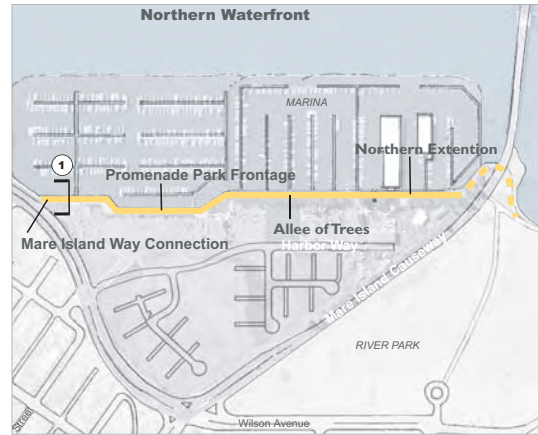

Figure 3.D.5: Promenade Segments in the Northern Waterfront



Figure 3.D.6: View Across Marina to Causeway Bridge



Figure 3.D.7: Photo of Existing Allee of Trees



Figure 3.D.8: Promenade along the Promenade Park

### Allee of Trees

The Allee segment of the Waterfront Promenade is viewed by a large number of people in the community as an important local landmark and amenity (See Figure 3.D.7). It should therefore become an integral part of the overall concept for improvements along the Promenade.

1. Maintain the allee of trees in its current condition.
2. Enhance the Promenade path with amenities such as pedestrian-scale lighting, benches and trash receptacles (“Promenade #1” light fixture combined with furnishings from the “Waterfront” palette). The pedestrian-scale light fixtures should be spaced at approximately 40 feet on-center to provide an appropriate level of lighting.

### Promenade Park Frontage

Large portions of this segment of the Promenade will be connected to the new Promenade Park and the outdoor patios associated with the proposed restaurant. The Promenade in this segment will be rebuilt as an integral part of the park and the restaurant patios. Figure 3.D.8 shows an illustrative design plan for the Promenade along Promenade Park. Pathways from Harbor Way establish critical pedestrian connections from Harbor Way and the residential development to the Promenade. The final design and programming of the park and this portion of the Promenade will be determined through a public process that will be conducted by the City.



Figure 3.D.9: Example of Promenade Focal Element

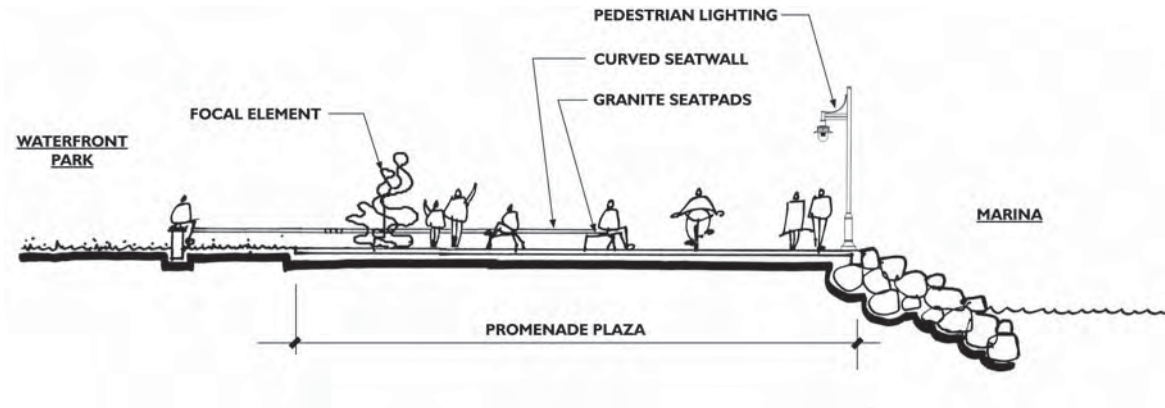

Figure 3.D.10: Promenade Adjacent to Waterfront Park



Along the Park frontage the Promenade widens to create a waterfront plaza area. Key elements of the plaza area include:

1. An interactive focal element, such as a fountain or sculpture, which celebrates the Vallejo Waterfront location (See Figure 3.D.9).
2. A space with multiple opportunities for seating, gathering, and people watching.
3. A low seat wall, which defines the edge of the park while providing unobstructed views of park activities.
4. Limited use of trees in the plaza to leave open views of water from adjacent areas.
5. Rows of columnar trees will be used to define major pedestrian connections between the Promenade and Harbor Way (Figure 3.D.11).
6. A comfortable transition should be provided between the restaurant dining patios and the Promenade through the use of landscaping, paving patterns, and other design elements.



Figure 3.D.11: Example of Allee Envisioned for Connection Between Harbor Way and Promenade.

### Mare Island Way Connection

This segment of the Promenade will be improved to enhance pedestrian movement and activities while preserving existing features, particularly in the southern portion of the segment. Figure 3.D.12 illustrates a typical cross section for the Waterfront Promenade in this segment.

1. Widen the existing Promenade from its current width of about 9 and 10 feet to 14 feet. This will provide a more comfortable accommodation for different activities and the expected increase of pedestrian travel in both directions.
2. Enhance the Promenade path with amenities such as pedestrian-scale lighting, benches, and trash receptacles (“Promenade #1” light fixture combined with furnishings from the “Waterfront” palette). The pedestrian-scale light fixtures should be spaced at approximately 40 feet on-center.

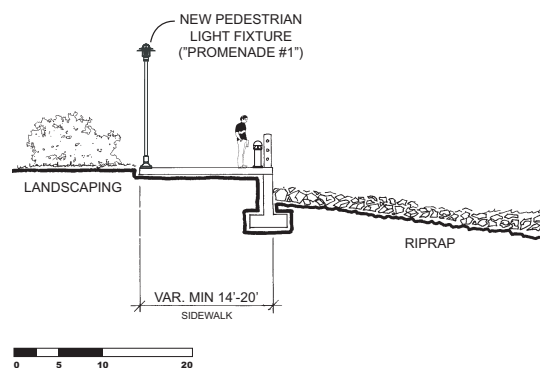

Figure 3.D.12: Improvements to Promenade Path and Lighting



Figure 3.D.13: Location View of the Proposed Wetland Park

## 2.2 Parks and Open Spaces Guidelines

### 2.2.1 New Wetland Park

This new 4.0 acre park will be located between the two residential neighborhoods and will extend from the Mare Island Causeway to Harbor Way. Several trail connections through the park will connect residents from outside the neighborhood and within the Mariner’s Cove neighborhood to the Waterfront. Interpretive signage will educate visitors on the wetland habitat and its function as well as provide a viewing area into the wetland across Harbor Way, to the Promenade Park and to Mare Island Strait. The transition from the built environment of the Mariner’s Cove neighborhoods to the more natural, informal open space environment of the wetland will be softened by berms and landscaped paseos. The berms will also act as a buffer between the private residences and the more public space of the Wetland Park, as well as enhance the natural setting for the wetland.



Figure 3.D.14: Example of a Wetland Park



Figure 3.D.15: Example of a Wetland Park



Figure 3.D.16: Plan View of the Proposed Wetland Park



Figure 3.D.17: Proposed Emergency-Vehicle-Access at Wetland Park



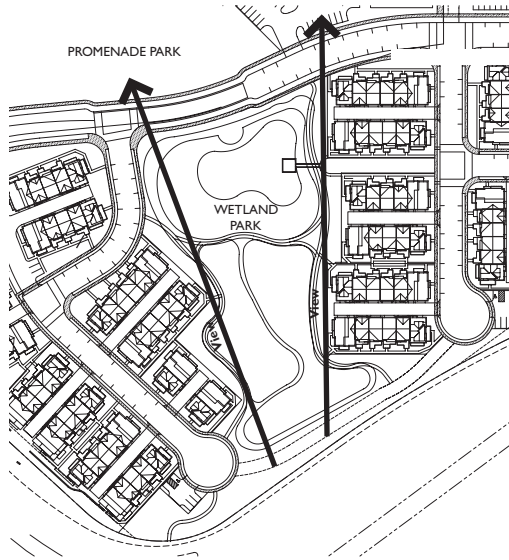

Figure 3.D.18: View Corridor through Wetland Park



Figure 3.D.19: Example of a Wetland Park Path

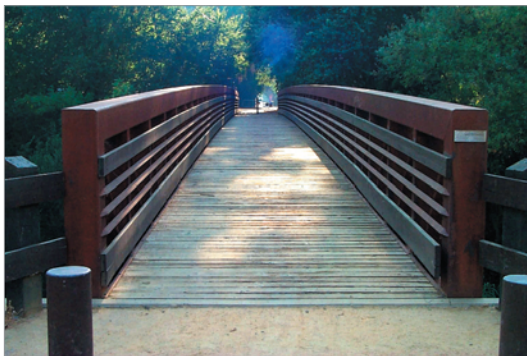

Figure 3.D.20: Example of a Wetland Park Bridge

1. The Wetland Park will connect visually and functionally with the surrounding residences and the Promenade Park. The surrounding residences will be connected to the open space by greenways or landscaped paseos. Evergreen planting and berms will screen the townhouse neighborhoods to offer residents greater privacy.
2. The park's seasonal wetland will be surrounded by meadows, usable for informal or passive recreation, and connected by a network of paths and bridges.
3. The Wetland Park will include emergency vehicle-only access constructed of grasscrete or similar material and will be located as depicted in Figure 3.D.17.
4. The surrounding residences will be connected to the open space by greenways or landscape courts.
5. Planting will include trees, shrubs and grasses along the swales, informal clusters of canopy trees edging the meadows, evergreen screening, and street trees along Mare Island Way, Harbor Way, and the internal streets of the residential neighborhoods.
6. The Wetland Park and the Promenade Park will be connected via landscaping and paving features to create a visual corridor from the Mare Island Causeway to the Mare Island Strait.

### 2.2.2 New Promenade Park

The 3.5-acre Promenade Park is the major new public space of the Northern Waterfront area (See Figure 3.D.25).

1. To enhance the community’s awareness of the park, the street trees along the western side of Harbor Way should be located to provide unobstructed views into the park and the waterfront beyond.
2. Clusters of palm trees are used to highlight edges of the park along Harbor Way and frame views from Harbor Way to the Waterfront.
3. A themed children’s play area could be provided to accommodate both tot and advanced play activities; the play area should include a comfortable area for parents to view activities. The play area should be visible from the park, but separate from the primary circulation to provide a level of security.
4. The park should include a large multi-purpose lawn area to accommodate a variety of informal sports uses. The lawn should be gently dished to provide ball control.
5. The park is well integrated into the overall pedestrian/ bicycle system by the Promenade and two pedestrian connections along the north and south edges of the park (See Section III.D.2.3.1 Harbor Way for information regarding the crossing of Harbor Way between the Promenade Park and the Wetland Park).
6. An enclosed dog park could be provided to allow for an “off-leash” area for dog owners to socialize.
7. Terrace lawn areas could provide areas for picnicking and also act as an informal amphitheater.



Figure 3.D.21: Location of Future Promenade Park



Figure 3.D.22: Example of Tot Lot Area



Figure 3.D.23: Example of a Multi-purpose Lawn Area

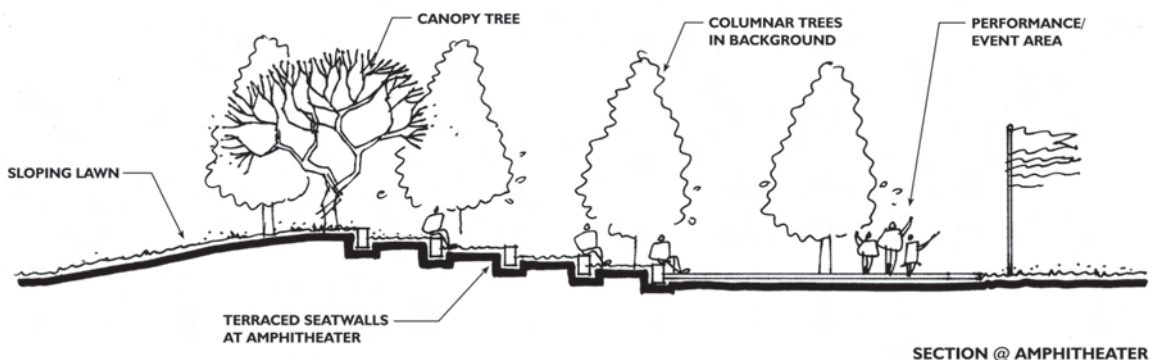

Figure 3.D.24: Illustrative Section of Amphitheater



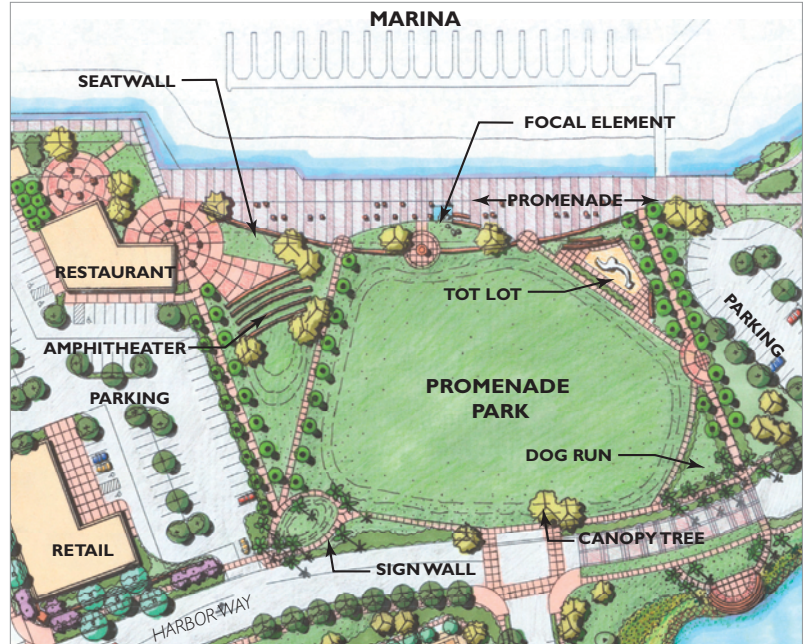

Figure 3.D.25: Illustrative Site Plan of Promenade Park

### 2.2.3 Restaurant Outdoor Patios

Uses that activate sidewalks and open spaces are particularly desirable along the Promenade in the Northern Waterfront. The proposed restaurant, toward the south end of the Northern Waterfront District, has particular potential to significantly enliven this stretch of the Promenade and the adjacent new open space (See Figure 3.D.27).



Figure 3.D.26: Location of Restaurant Patios at Promenade

1. Provide a direct spatial relationship between outdoor seating areas associated with the restaurant and the Waterfront Promenade. While the use of landscaping is encouraged it should be located so as to frame views to and from outdoor seating areas and the Promenade, and not to delineate a visual barrier between the two areas. Overall, outdoor seating areas should feel like an extension of the Promenade rather than separate from it.
2. If wind screening of the patios is deemed necessary it should be clear and not block the visual connection between the patio spaces and the Waterfront Promenade.
3. Activities along the Promenade and in Promenade Park should be visible from patio areas. The pedestrian connections between the Promenade and Harbor Way should be located adjacent to outdoor patio spaces.



Figure 3.D.27: Illustrative Plan of Restaurant Patios at Promenade

## 2.2.4 Walls and Fences

1. No walls or fences should be used to close off the Mariner's Cove residential development from adjacent streets. However, low linear landscape features up to a height of 18 inches may be used to delineate the border between the private and public realms in the area.
2. In order to facilitate a character of openness and accessibility, any vertical, linear landscape feature such as the one described above, should include openings that allow for paths to pass through. Figure 3.D.28 illustrates the suggested approximate location of such passage points. Consideration should be given to enhancing the most prominent passage points by adding a vertical landscape feature such as a trellis or arbor framing the pass through.

Where this feature is used to also function as a retaining wall where buildings side onto it, steps should be provided to allow for adequate access of side yard areas.

3. Where grade differences exist between sidewalks and adjacent landscape or other areas, the installation of safety railings may be required by building or other codes. Such railings may be installed at any height required by applicable codes. It is expected that conditions that require the installation of railings will likely occur on portions of the sidewalk along the Mare Island Causeway. Railings should be designed as artful visual enhancements of the adjacent pedestrian realm rather than as utilitarian features.



Figure 3.D.28: Approximate Location of Passages Through Vertical Landscape Features

## 2.3 Circulation Guidelines

The following provides design guidance for different segments of Harbor Way, the principal access street of the Northern Waterfront, a typical street of the residential development east of Harbor Way, and for sidewalks along Mare Island Causeway.

### 2.3.1 Harbor Way

Harbor Way is the primary street that will access all future and existing uses in the Northern Waterfront area, including new and existing retail uses; the Mariner’s Cove residential neighborhood on the east side of the street; the Coast Guard, Harbor Master, and marina facilities; as well as a new restaurant at the Waterfront Promenade. In order to appropriately serve these diverse uses, the design of the street’s edge conditions adjust to the particular conditions and requirements of adjoining uses. 12-foot travel lanes were selected over 11-foot lanes to accommodate the types of vehicles and trailers associated with the marina-related uses.

Figures 3.D.30 through 3.D.36 illustrate the relationship of the street to adjacent uses, such as different surface parking conditions (3.D.32), parks (Figure 3.D.33 and 3.D.34) and residential buildings (Figure 3.D.30, 3.D.31 and 3.D.35).



Figure 3.D.29: Harbor Way and Section Location Diagram

Figure 3.D.30 and 3.D.31 illustrate two alternatives for the northernmost end of Harbor Way fronting the Mariner’s Cove development. The re-grading of the site for drainage purposes could result in a higher elevation at the northern end of the development, which would raise the finish floor elevations of the buildings above the grade at Harbor Way. The options above demonstrate two alternatives for resolving this issue. Option A is preferred as it maintains the character and configuration of the pedestrian realm in a consistent manner to the rest of Harbor Way by keeping the tree lawn between the sidewalk and the curb. Option B moves the sidewalk adjacent to the curb creating a monolithic sidewalk condition.

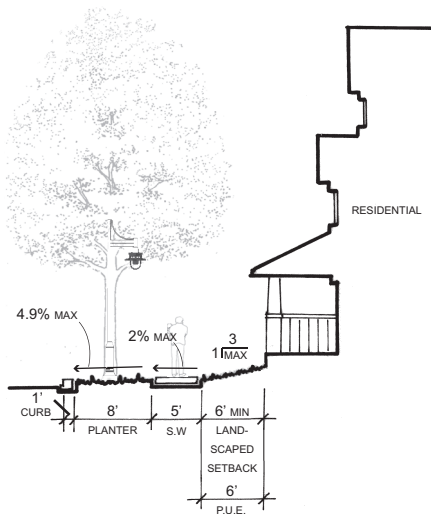

Figure 3.D.30: (Option A - Preferred) Harbor Way Partial Cross Section at Parking with Tree Lawn and Separated Sidewalk ①

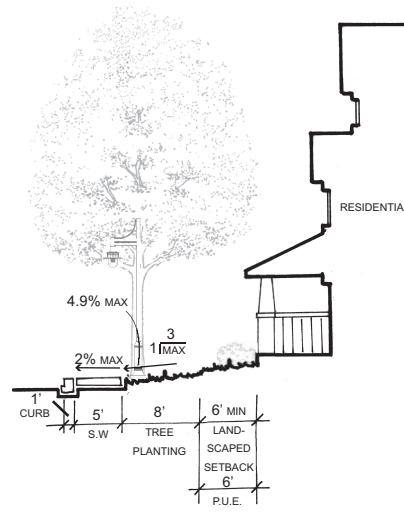

Figure 3.D.31: (Option B) Harbor Way Partial Cross Section at Parking with Monolithic Sidewalk ①



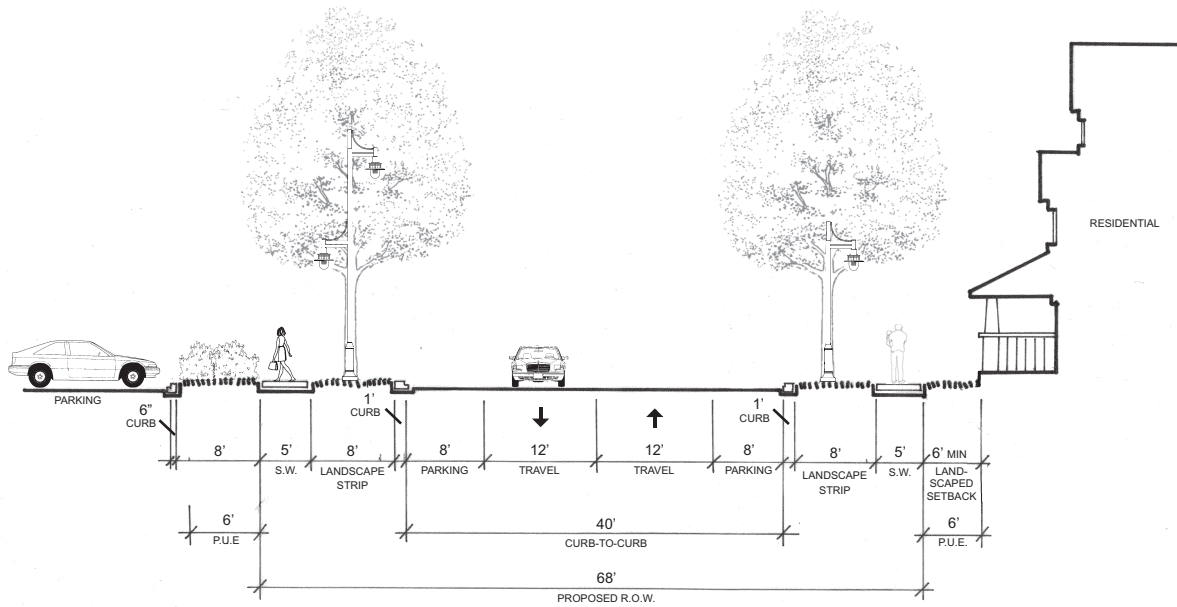

Figure 3.D.32: Harbor Way Partial Cross Section at Parking (2)

Figure 3.D.34 illustrates the design concept for the special design treatment for the pedestrian crossing between the Wetland Park and the Promenade Park. The on-street parking that is provided along the majority of Harbor Way is eliminated on both sides of the street in order to shorten the crossing distance for pedestrians. When combined with special concrete paving (e.g., colored and/or textured concrete) within the roadway, this enhances the quality and safety of the crossing encouraging traffic to slow and bringing the pedestrian crossing to the attention of drivers.

Figure 3.D.35 illustrates the street as it transitions from the intersection at Mare Island Way where a center turn lane is provided, to a more residential and pedestrian-oriented street. Parking is eliminated on either side of the street to preserve views into the open space and waterfront.

Figure 3.D.36 also illustrates the street’s configuration close to the intersection with Mare Island Way. Here, on-street parking is discontinued to allow designated left turn lanes out onto Mare Island Way and into the retail parking lot.

The Ornamental Pear (*Pyrus Calleryana ‘Aristocrat’*) is the proposed typical street tree for Harbor Way. Along park frontages and the entry greens at Mare Island Way, however, Southern Live Oak (*Quercus Virginiana*) and the Evergreen Elm (*Ulmus Parviflora*) will be used to reflect the larger landscaped character of these open space and park frontages.



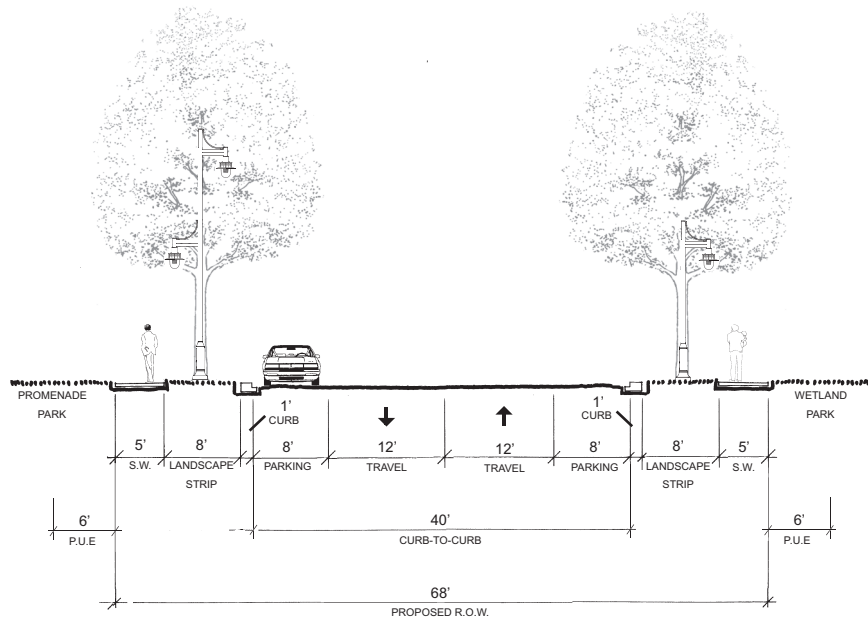

Figure 3.D.33: Harbor Way Cross Section at Park (3)

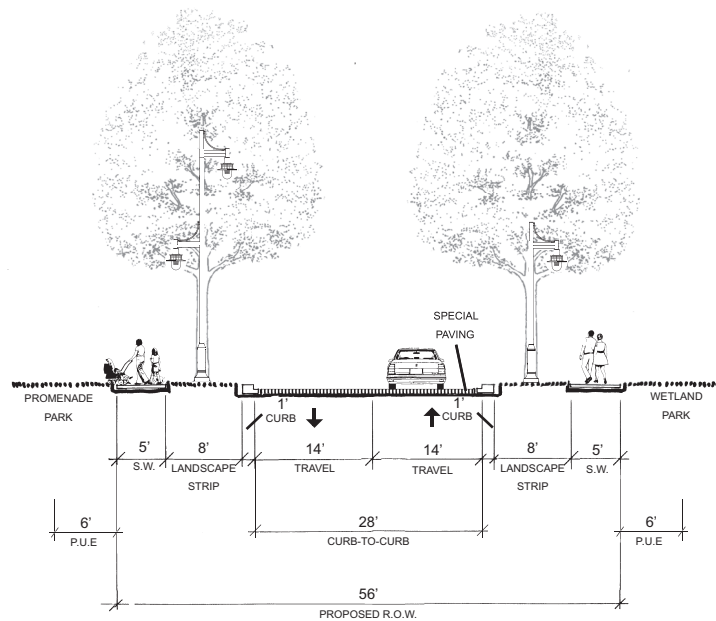

Figure 3.D.34: Harbor Way Cross Section at Park (4)

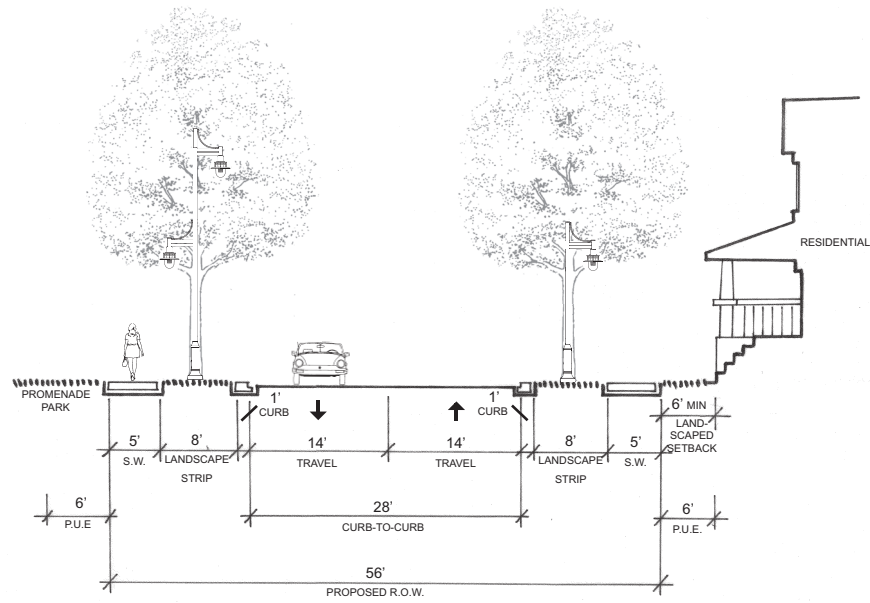

Figure 3.D.35: Harbor Way Cross Section at Residential (5)

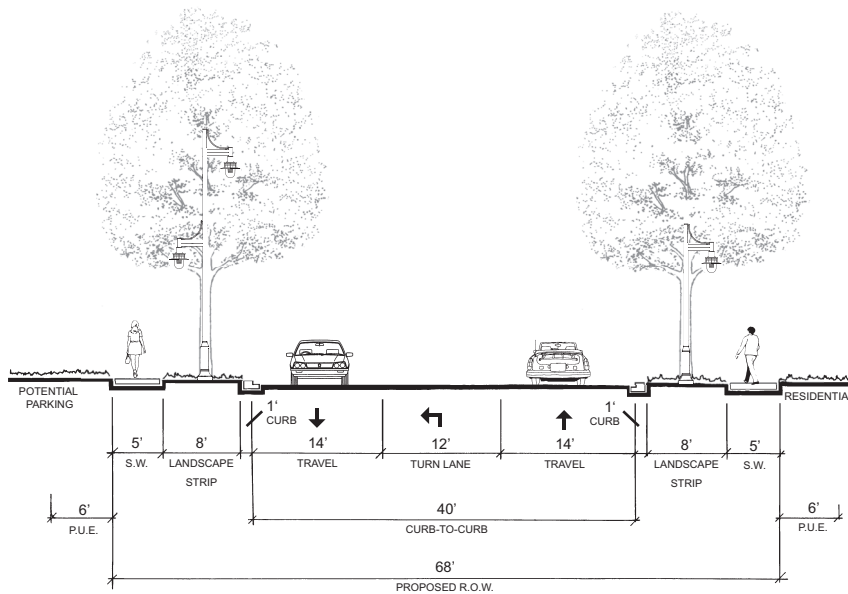

Figure 3.D.36: Harbor Way Cross Section at Intersection (6)

### 2.3.2 Mariner's Cove Residential Streets

#### 2.3.2.A Typical Residential Street

The overall width of the public right-of-way of a typical residential street within Mariner's Cove is 53 feet. Roadway and sidewalk widths of this street are as compact as possible to increase the depth of landscaped front yards and to reduce the amount of impervious, paved surfaces. In order to achieve this goal travel lanes are 11 feet wide and parking lanes are 7 feet wide (See Figure 3.D.38). Sidewalks of 4-foot width provide accessibility for pedestrians, who may also use the pathways connecting the residential courts and those along the Wetland Park to move around the neighborhood. A tree-lined landscape strip between roadway and sidewalk provides a visual delineation and separation between the roadway and adjacent residential buildings, and enhances the residential character and pedestrian-supportive nature of the street. Pedestrian-scale light fixtures will also be located in the landscape strip. The Ornamental Pear (*Pyrus Calleryana* 'Aristocrat') is the proposed typical street tree for the Mariner's Cove residential streets.

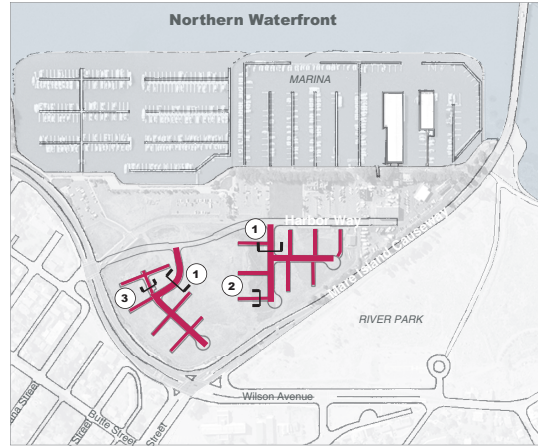

Figure 3.D.37: Mariner's Cove Residential Street and Section Location Diagram

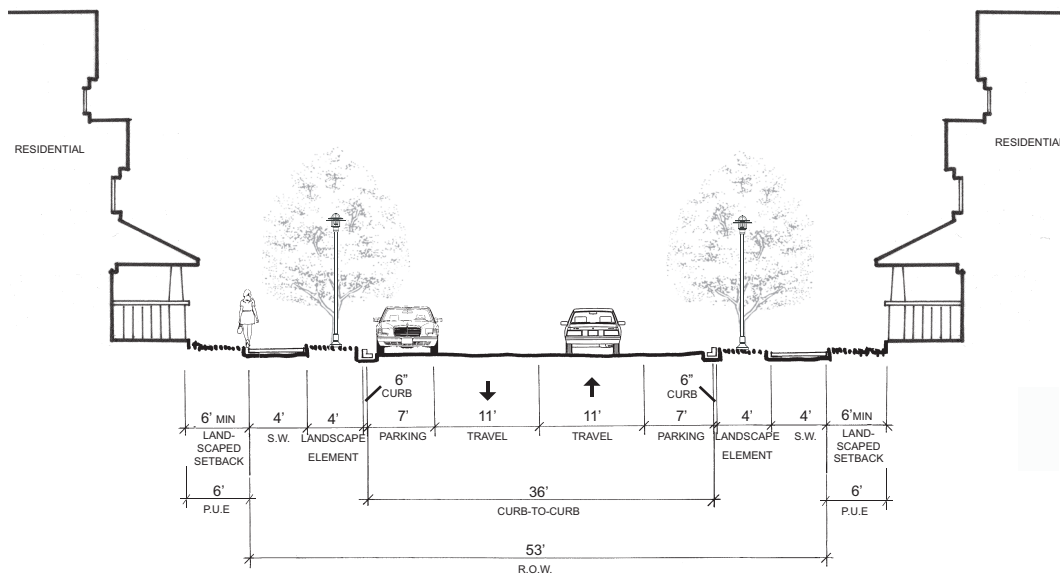

Figure 3.D.38: Mariner's Cove Residential Street Cross Section (Typical) ①

### 2.3.2.B Typical Private Court Roadway

Private courts provide access to garages located in the rear of the residential buildings in the Mariner’s Cove development. Garages internal to the buildings are typically accessed via a 4-foot concrete drive, which is separated from the curbsless roadway by a 6-inch wide concrete band. Drainage occurs through a 3-foot wide, concrete valley gutters located at the center of the 20-foot wide roadway (See Figure 3.D.39). The compact layout of the private court promotes slow driving and careful maneuvering.

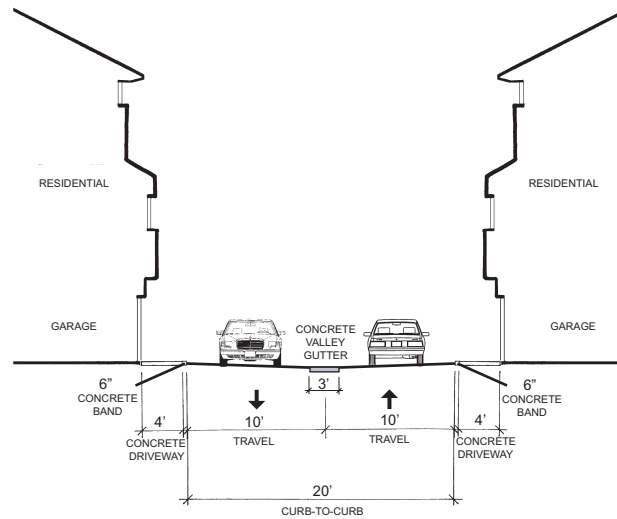

Figure 3.D.39: Cross Section of Typical Private Court Roadway ②

2.3.2.C Typical Private Entryway at 'T' Court Road

In locations where private residential courts are not directly accessed from a loop road, a short street segment provides a connection from the street to the private court road. This segment should typically be fronted by residences with a wrapped porch fronting both the 'T' Court Road and the adjacent street. The configuration of such a street segment is illustrated in Figure 3.D.40. While sidewalks have the same width as along the typical residential streets, they are not separated from the roadway by a tree-lined landscape strip and through a curb and gutter, but rather a continuous concrete band that is not raised above the surface of the roadway. Instead, a 6-inch wide concrete band creates a visual separation between the edge of the sidewalk and the adjacent travel lane. Drainage is achieved through 3-foot wide, concrete valley gutters located at the center of the 28-foot wide roadway. Parking is not permissible along this type of street.

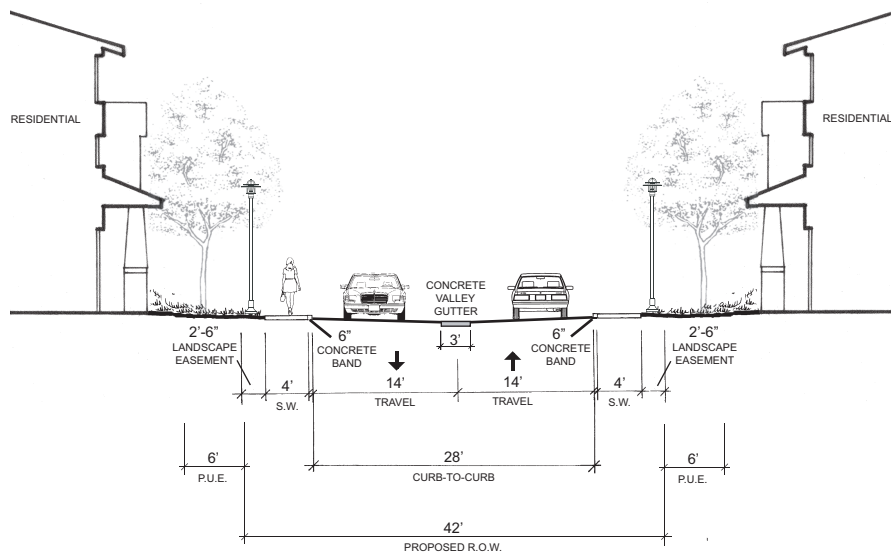

Figure 3.D.40: Cross Section of Typical Private Entryway at T-Court ③



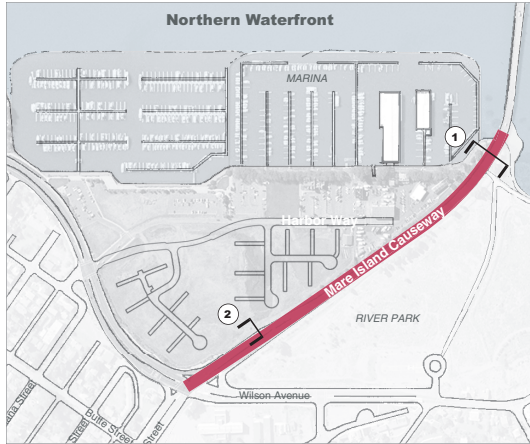

Figure 3.D.41: Mare Island Causeway and Section Location Diagram

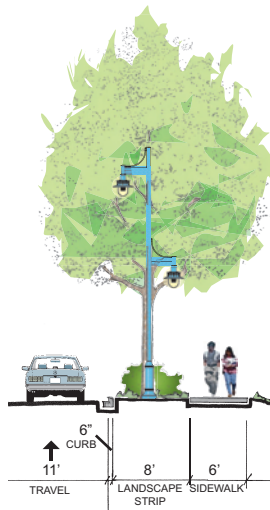

Figure 3.D.42: Partial Cross Section of Typical Sidewalk and Lighting Improvements on Southside of Mare Island Causeway ①

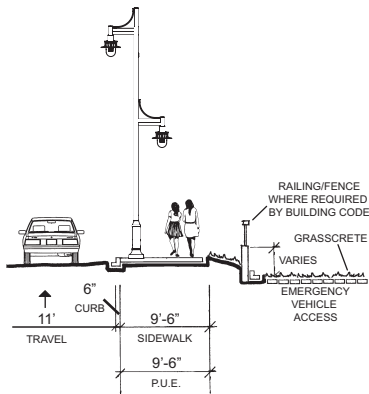

Figure 3.D.43: Mare Island Causeway (Constrained) - Partial Cross Section ②

### 2.3.3 Mare Island Way and Mare Island Causeway Edges

#### 2.3.3.A Mare Island Causeway Edge

Figure 3.D.42 illustrates the typical sidewalk improvements that could occur in this section of Mare Island Causeway between the bridge and the western end of the new development. The proposed improvements include an 8-foot wide landscaped and tree-lined buffer that provides a separation between pedestrians and moving traffic. The addition of pedestrian-scale fixtures along the entire length of the street is intended to increase the visibility of pedestrians and their sense of safety.

The northeastern portions of the Mariner’s Cove residential development directly abut the Mare Island Causeway. A grade difference of about 5 feet exists where the internal residential street parallels the Causeway and its sidewalks. This condition will become even more constrained with the pending addition of a second right-turn lane on Mare Island Causeway, which will further reduce the width of the landscaped area between these two streets and creates the need for a retaining wall. These conditions limit the opportunity for providing wider sidewalks and a substantial landscape buffer along the Causeway similar to those proposed for the segment between the causeway structure and the edge of the new development (Illustrated in Figure 3.D.42). However, it is expected that the volumes of pedestrians that will be using this route for travel to destinations in other parts of town will be limited. This will particularly be the case if the new path connection from the Causeway to the Promenade below is implemented (See Section III.D.2.3.4 Trail Connections).

Figure 3.D.43 illustrates the typical section for the sidewalk along this constrained segment of the southern edge of the Causeway. Where the future widened Causeway and the new residential street are located in close proximity to one another, a retaining wall will make up some of the grade difference. A railing atop the retaining wall will be provided where this is necessary to ensure pedestrian safety.



Figure 3.D.44: Mare Island Way and Section Location Diagram (For a description of section nos. 3 through 7, see Central Waterfront Section 2.2.1.G; For a description of section no.8, see Southern Waterfront Section 2.2.1.F.)

### 2.3.3.B Mare Island Way

The following series of cross-sections, shown in Figure 3.D.44, illustrate how specific conditions along a segment or in a particular location on Mare Island Way in the Northern Waterfront should be reflected in the design of the cross-section of the entire street or the street's edge condition.

The following sections are organized by location beginning at Mare Island Way's northern end.

#### **Mare Island Way between Mare Island Causeway and Harbor Way**

Figure 3.D.45 illustrates the current configuration of Mare Island Way near Alabama Street, (with the exception of the shown palm trees and pedestrian-scale light fixtures, which represent proposed additions to the existing streetscape in order to provide consistency with future improvements along other segments of the street). Here, pedestrians on the west side of the street are separated from traffic by a substantial landscape buffer of varying width. The sidewalk essentially has the character of a trail. This is appropriate as there are no existing or future uses that directly address the street and no destinations where pedestrian access would need to be provided to. On the east side of the street, pedestrians are somewhat buffered by the bike lane on Mare Island Way, however, it is anticipated that relatively few pedestrians would use this side of the street for longer travel along the busy arterial.

The addition of trees and pedestrian-scale light fixtures are the only changes proposed for this segment of Mare Island Way. Widening of the roadway may occur based on potential future improvements at the Tennessee Street/Mare Island Way intersection.

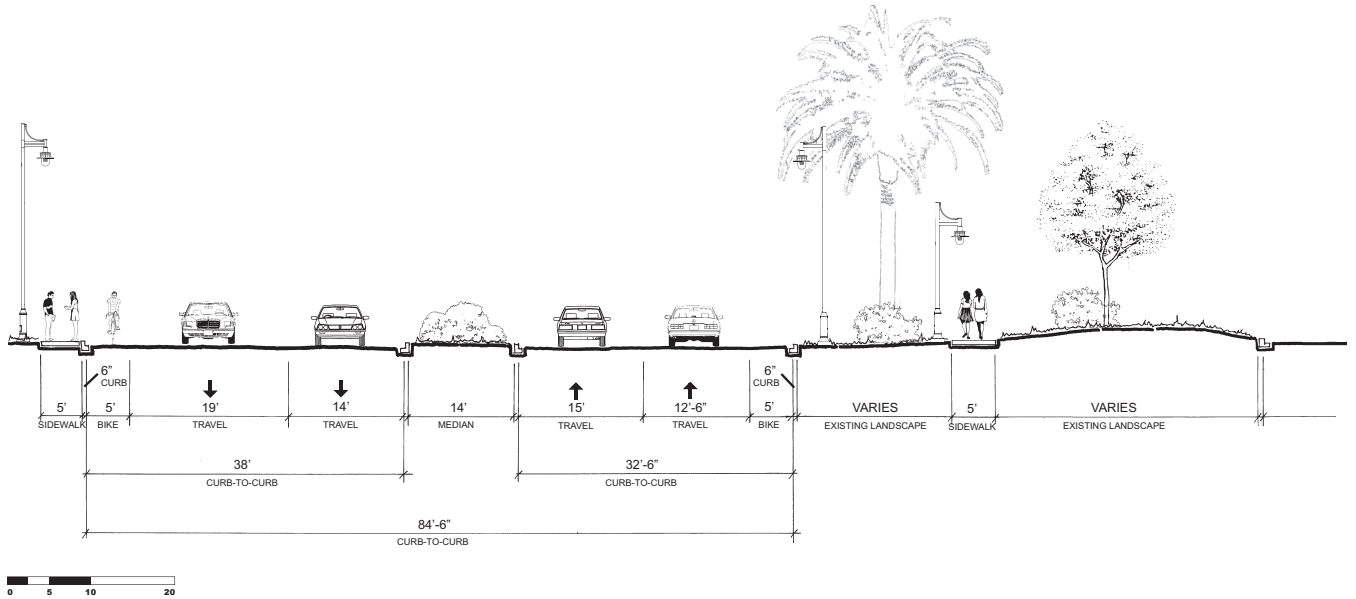

Figure 3.D.45: Section of Mare Island Way near Alabama Street ①

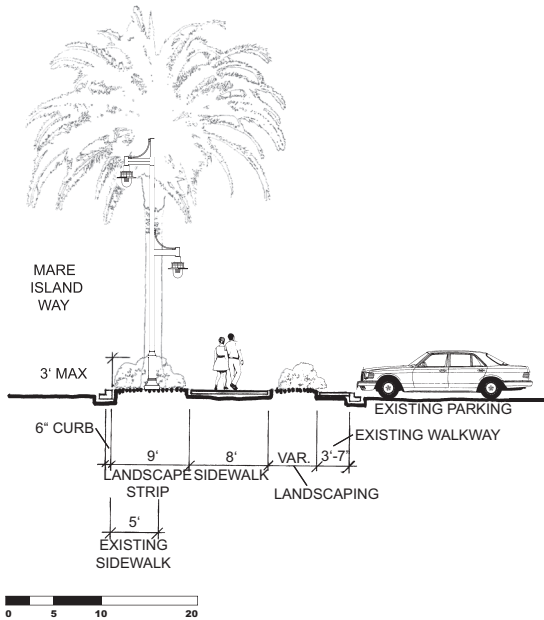

Figure 3.D.46: Partial Section of Mare Island Way near Ohio Street ②

### Mare Island Way from Harbor Way South to Kentucky Street

Figure 3.D.46 illustrates how the pedestrian environment can be significantly improved by widening the sidewalk to 8 feet and by introducing a tree-lined landscape strip that acts as a buffer between pedestrians and moving traffic on Mare Island Way. The landscape along the back of the sidewalk provides a visual screen and buffer toward the proposed parking lot.

### Mare Island Way from Kentucky Street to Capitol Street

Improvements in this section of Mare Island will likely be minimal for the foreseeable future, as it was recently improved and little or no new development is planned in this area. Yet installation of pedestrian fixtures attached to the existing roadway fixtures and the planting of street trees to match the rest of the street would support the concept of Mare Island Way serving as a major linkage between the three Waterfront Districts (Note: This section is repeated in *Section III.C.2.2.1.G Mare Island Way* due to overlap in District boundaries).

### 2.3.4 Trail Connections

**Trail Connection:** This is the Mare Island Causeway Promenade Connection at the eastern end of the Mare Island Causeway structure.

#### 2.3.4.A Mare Island Causeway Promenade Connection

This new trail connection will provide direct and convenient access for pedestrians and bicyclists into the Northern Waterfront. This location is an important- yet currently poorly functioning- access point to River Park to the north and the Waterfront Promenade to the south of the Causeway. Two related sets of improvements are necessary to create a safe and functional gateway in this location (See Figure 1.B.1):

1. **Promenade Extension:** Improving the existing north-south trail connection underneath the Causeway structure to become an extension of the Waterfront Promenade, which should include the installation of a focal point in the form of an overlook and seating area as well as pedestrian-scale lighting and landscaping.
2. **Multi-purpose Trail Ramp:** Providing direct access between the southern sidewalk of Mare Island Causeway and the existing trail adjacent to the water's edge, located 10 feet below.

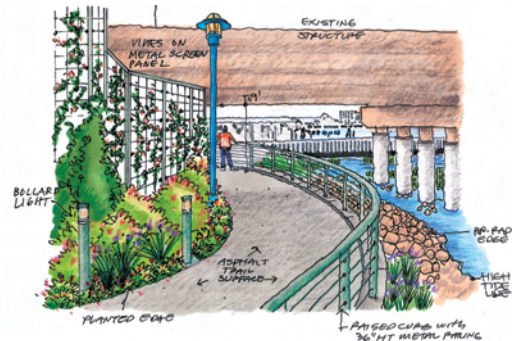

Figure 3.D.47: Sketch Concept of Trail Connection under the Causeway Overpass Looking South

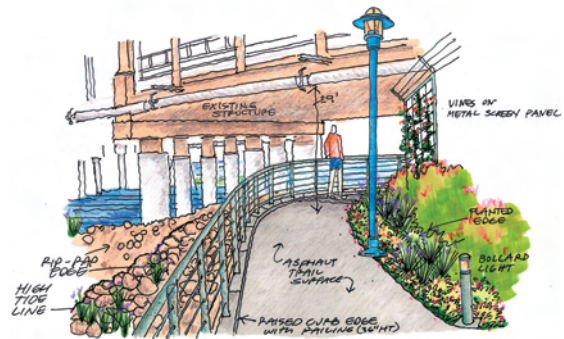

Figure 3.D.48: Sketch Concept of Trail Connection under the Causeway Overpass Looking North

#### Promenade Extension

The Promenade should be extended from the end of the existing improvements near the Coast Guard facility as an 18-foot wide, multi-use path that accommodates pedestrians and bicyclists. The Promenade extension should provide a connection under the Causeway to connect with the path system in the River Park to the north of the Causeway. The sketch plan and perspectives in Figures 3.D.47 and 3.D.48 illustrate how the trail connection under the overpass can be improved with lighting, railings, attractive planting, and seating (focal point with overlook and seating is not shown). Pedestrian light fixtures (See *Section II.B.1.1.0.B Fixture #2*) should be added along both the ramped path from the Causeway to the trail and along the trail itself.

#### Multi-purpose Trail Ramp from Causeway to Promenade Extension

A 10-foot wide path can provide the desired connection between the sidewalk of Mare Island Causeway and the Promenade extension below. The ramped trail should be designed to allow pedestrians, bicycles, and those in wheelchairs to safely make the connection between the Causeway and the Promenade extension. The opportunity to provide seating along the ramp so that people can stop to enjoy the view should be considered. An aboveground sewer line traverses the area between the Causeway and the Promenade, and its location and the details of crossing it should be addressed as the design for the access ramp is further developed. The ramp should be lighted with the Promenade Standard #2 fixture (See *Section II.B.1.1.0.B Fixture #2*) to provide consistency with lighting along the Promenade (See Figure 3.D.49 and Figure 3.D.50).





Figure 3.D.49: Sketch Concept of Trail Connection under the Causeway Overpass (arrows and lines indicate location of section - See Figure 3.D.50)

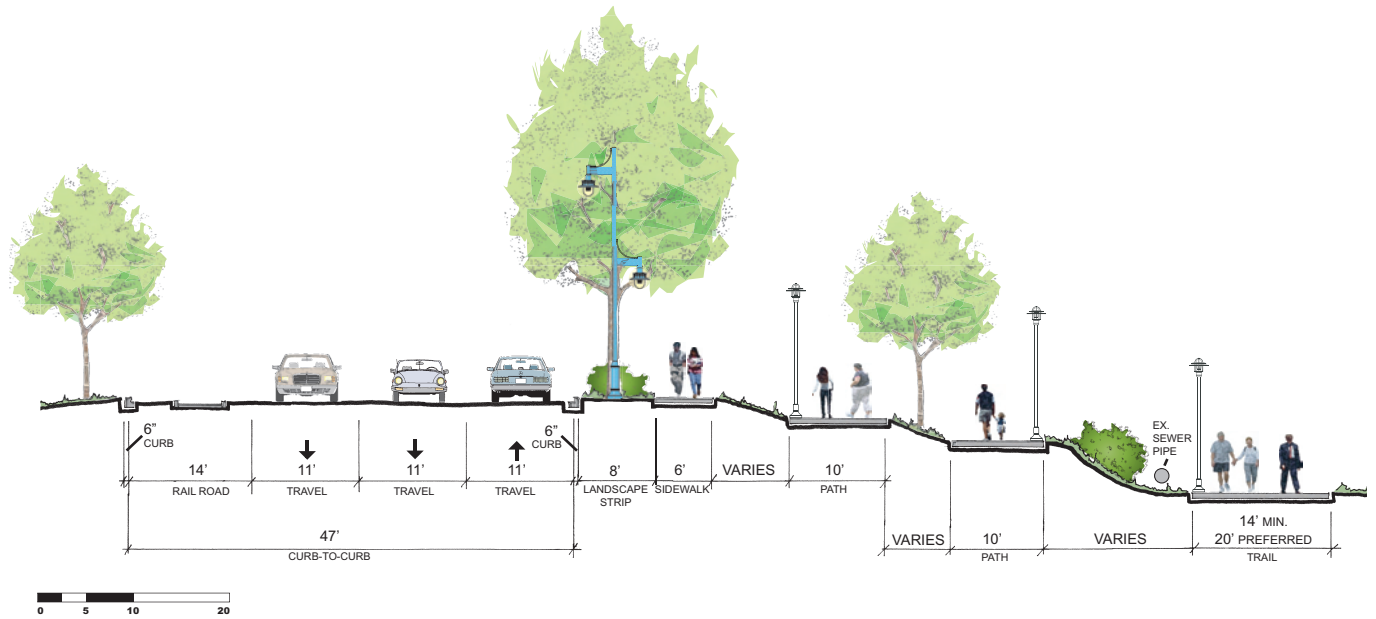

Figure 3.D.50: Partial Cross Section of Mare Island Causeway at Proposed Multi-purpose Trail Ramp Connection to Promenade Extension



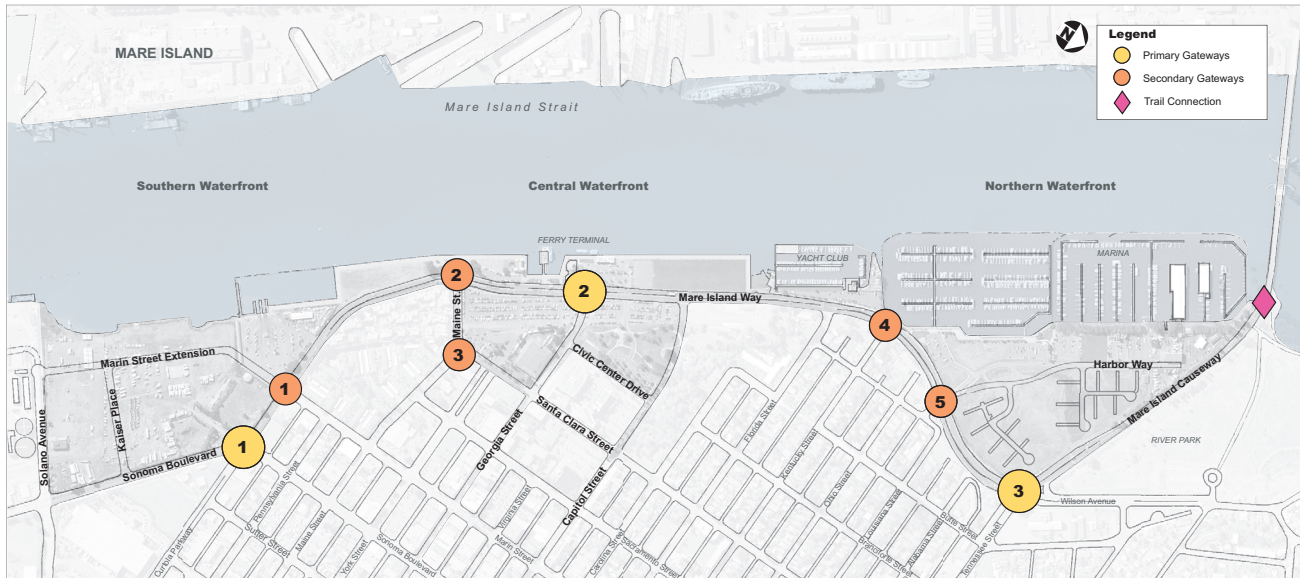

Figure 3.D.51: Diagram of Primary and Secondary Gateways

## 2.4 Gateways

### 2.4.1 Primary Gateway

The northern gateway is located at the intersection of Mare Island Way, the Mare Island Causeway, Tennessee Street, and Wilson Avenue. This is the most challenging gateway to the Waterfront, because of the scale of the intersection, and because the four roadways that intersect here provide access to distinct areas of Vallejo and in some cases important regional transportation connections. The southwest corner of this intersection is visible for those who are approaching the Waterfront from either Wilson Avenue or Tennessee Street. The improvements to Parcel A in the Northern Waterfront District include this corner and propose to construct an accent wall and landscaping in this location. In addition, the street trees and general streetscape improvements that are proposed for Mare Island Way could be used to frame the proposed accent features and highlight this point as a major gateway to the Waterfront. Similarly, street trees and other elements of the streetscape improvements could be used in the park space at the southeast corner of the intersection to further frame this gateway.



Figure 3.D.52: Location Diagram for Secondary Gateway at the Intersection of Harbor Way and Mare Island Way

### 2.4.2 Secondary Gateways

Secondary Gateways within the Northern Waterfront are located at the intersections of Mare Island Way and Harbor Way and Mare Island Way and Kentucky Street. The intersection of Mare Island Way and Harbor Way is the principal vehicular access and entry point into the Northern Waterfront. All vehicular traffic as well as pedestrians and bicyclists approaching from across and along Mare Island Way will pass this gateway (No. 5 in Figure 1.2). Therefore, this location should have visual emphasis through the use of ornamental landscaping and landscape structures on either side of Harbor Way and in close proximity to the corner of Mare Island Way. The landscaped areas between sidewalks and buildings should complement the ornamental landscaping around the entry features (Figure 3.D.53 illustrates an example of this condition in plan view).

To provide views from Mare Island Way into the Promenade Park area, the northern edge of the intersection is envisioned as an open lawn area. A low linear landscape feature, whose height is not to exceed 18 inches, and the planting of ornamental trees would define the edge of the lawn area. A sign, which may be taller than 18 inches, could be integrated into the linear landscape feature.



Figure 3.D.53: Design Concept for Secondary Gateway at the Intersection of Harbor Way and Mare Island Way

The gateway at Kentucky Street highlights the importance of the connection between the neighborhoods on the bluff and the Vallejo Waterfront.

### 3. Private Realm Guidelines

The specific Guidelines for the private realm in the Northern Waterfront District are organized into two sub-areas: the Mariner's Cove residential neighborhood clusters on Parcel A to the east of Harbor Way, and the retail commercial areas on the west of Harbor Way.

#### 3.1 Site Design and Building Orientation

Individual buildings, parking lots, and landscaped setbacks and buffers in the Northern Waterfront District should create a visual continuum with the existing and proposed parks and playgrounds, the Waterfront Promenade, and Harbor Way, that is visually pleasing when experienced from within Mariner's Cove as well as when viewed from areas outside of the District. The following Guidelines will guide this integration.

##### 3.1.1 Relationship of Buildings to Streets and Open Spaces

###### *Mariner's Cove Residential Neighborhood*

The residential area of the Mariner's Cove development is bounded by Mare Island Way, the Mare Island Causeway and the realigned Harbor Way, which create a triangular shaped site. A landscaped buffer of varying slope is located along Mare Island Causeway and the majority of the frontage along Mare Island Way, and should provide a 'natural' sound and sight buffer to the buildings in the new residential neighborhood. Three residential cul-de-sac streets provide vehicular access to residential buildings largely through a direct connection to private court roads (lined with garages) and, in a single instance, through a short street segment (T-alley). Pedestrian access is provided along the residential streets with sidewalks, an extensive network of landscaped paseos and garden courts throughout the site, as well as a trail network within the Wetland Park (See Figure 3.D.54).

1. Buildings should be oriented to either face a street with sidewalks or one of the many landscaped paseos or garden courts.



*Figure 3.D.54: Example of Building Relationship to Adjacent Landscaped Passage*



2. Where feasible based on the overall geometry of the site, a T-alley configuration should be applied to reduce the visibility of garages from streets with sidewalks (See site plan in Figure 3.D.3).
3. Porches and stoops should be oriented toward street-facing front yards or landscaped paseos and garden courts to provide a comfortable transition between these public and semi-public realms of the street and the private realm of the residential units.
4. Corner buildings at roadway intersections and/or intersections of roadways and landscaped paseos and garden courts should provide porches facing either of those circulation elements.

### ***Waterfront Retail***

While in the Central Waterfront building frontages will create direct connections to the public realm of adjacent streets, this relationship is going to be less direct in the Northern Waterfront. This is due to the need to accommodate parking in surface rather than underground parking lots, setbacks related to the preservation of views, and ornamental landscaping in conjunction with gateway designs and the Waterfront Promenade. This approach will create a more landscaped environment that is in keeping with the landscaped character of the surrounding neighborhoods and River Park to the north.

Based on these conditions, it is important to create safe and functional pedestrian connections between street sidewalks, buildings, and adjacent parking lots as well as a mutually enhancing relationship between buildings, landscaping, open spaces, and the Waterfront Promenade. However, a direct relationship between buildings and the adjacent street should be established where this is not precluded by other goals and Guidelines.

### 3.1.1.A Building Setbacks

#### Mariner’s Cove Residential Neighborhood

Building setbacks for residential buildings in Mariner’s Cove should follow the Guidelines indicated in the table below. The separation between adjacent buildings should not be less than 25 feet.

Building Setback	Minimum	Preferred
Mare Island Way and Mare Island Causeway	30 feet	60 feet
Harbor Way and Internal Streets	13 feet	25 feet
Landscaped Passages (separation between buildings)	25 feet	40 feet

Table 3.D.1: Building Setbacks and Separation

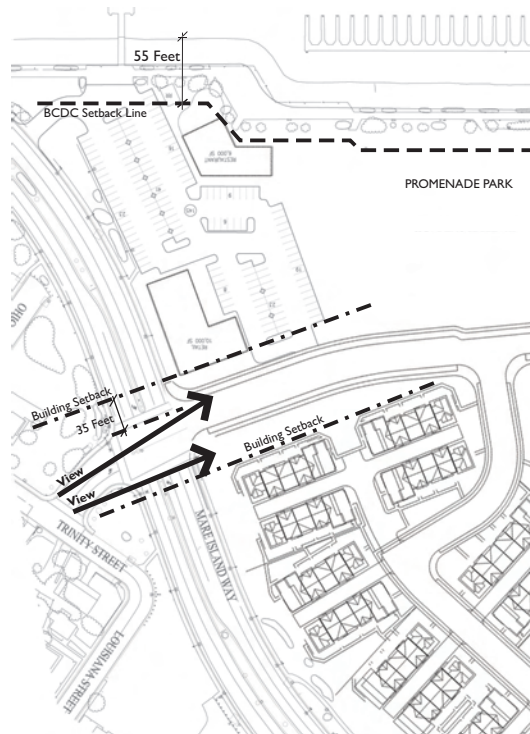

Figure 3.D.55: View Corridor and Waterline Setback Lines

#### Waterfront Retail

1. Retail building at the corner of Harbor Way and Mare Island Way: The northeastern face of the building should be set back from the back-of-curb along Harbor Way by 35 feet to provide a view corridor from Mare Island Way and Trinity Street into the site and to boat masts and views of the waterfront. Landscaping in this setback should be selected and designed as an integral part of the future gateway at the entry to Harbor Way (See Figure 3.D.55).
2. Retail Building at Harbor Way North of Harbor Master Building: The building should be separated from the sidewalk by a landscaped setback that, at its narrowest point, is 10 feet deep. At the entry, a small plaza should provide a direct connection with the adjacent sidewalk to activate the street with pedestrian activity (Also see *Section III.D.3.1.2.A Entry Orientation Guidelines*). The pedestrian path from Harbor Way to the Promenade that runs adjacent to the northwestern building façade, is an important connection to the Waterfront. If the final floor plan requires that more than 50% of this frontage consist of a blank wall, should it become the building’s service area, a minimum 7-foot wide landscape buffer should be provided to allow for effective screening of the retail building’s service façade with trees, tall shrubs, vines and/or other vertical elements, to create a more interesting environment along the adjacent walkway.
3. Restaurant Building at Promenade: No portion of the restaurant building should be located closer to the high water mark than 55 feet (as defined by the Bay Conservation Development Commission; Also see Figure 3.D.55). The building and its surrounding landscaping and hardscaped “patio” seating areas should engage the Promenade and make activity within the building visible to the Promenade.





Figure 3.D.56: Sample Residential Building Side Elevation (Southern Neighborhood)

### 3.1.1.B Building Frontage

#### **Mariner's Cove Residential Neighborhood**

1. Streets and residential building locations in Mariner's Cove should be laid out to maximize the number of units that front onto a landscaped paseo, garden court, major landscaped setback, or the Wetland Park.
2. The orientation of buildings should provide a visually engaging variety that is supported by the geometry of the site and the resulting layout of the network of streets and landscaped paseos. This approach should include stretches of alternating elevations along Harbor Way, the internal neighborhood streets, landscaped paseos and garden courts.
3. In order to support the desired overall character of a neighborhood well-integrated into a strong landscape framework, a monotonous, unfaltering series of recurring frontage conditions should be avoided. The architectural detailing of buildings and particularly the design of end unit frontages should support this approach by varying in treatment and in configuration. The same concept should also be applied to internal landscaped paseos to create a variety of front and side elevations.

### **Waterfront Retail**

1. Retail Building at Corner of Harbor Way and Mare Island Way: While the majority of visitors will be arriving by car and accessing the building from the parking lot side, it is critical that the building frontage toward Mare Island Way and Harbor Way include frontages comprised of windows and visually engaging architectural detailing.
2. Retail Building at Harbor Way North of Harbor Master Building: The eastern façade of this building should directly relate to Harbor Way with a small, paved plaza at its corner entry (Also see *Section III.D.3.1.2.A Entry Orientation Guidelines*), and ornamental landscaping along its setback between sidewalk and building façade. The landscaping should be designed so as to not block views of display windows and activity in the building's interior. Both eastern and southern frontages should be considered the building's primary frontages and consist of display windows.
3. Restaurant Building at Promenade: All building frontage along the Waterfront Promenade should be considered primary frontage and directly relate to patios for outdoor dining and associated landscape areas. Except for the drop-off area close to the building entry, the sidewalk along the building's frontage toward the parking lot should be buffered from adjacent parking by landscaping to screen views from the building into the parking lot.

### **3.1.2 Building Entries and Access**

#### **Waterfront Retail**

Irrespective of whether entries are oriented toward a street or a parking lot, they should be easily recognizable to the arriving visitor and functionally well designed. While the retail buildings in the Northern Waterfront are likely to be primarily accessed from their parking lot side, their relationship to the public realm of surrounding streets, parks, and the Waterfront Promenade can be strengthened by either providing a corner entrance that is visible and accessible from both parking lot and sidewalk, or by providing a second entrance that is oriented toward the adjacent street or the Waterfront Promenade.

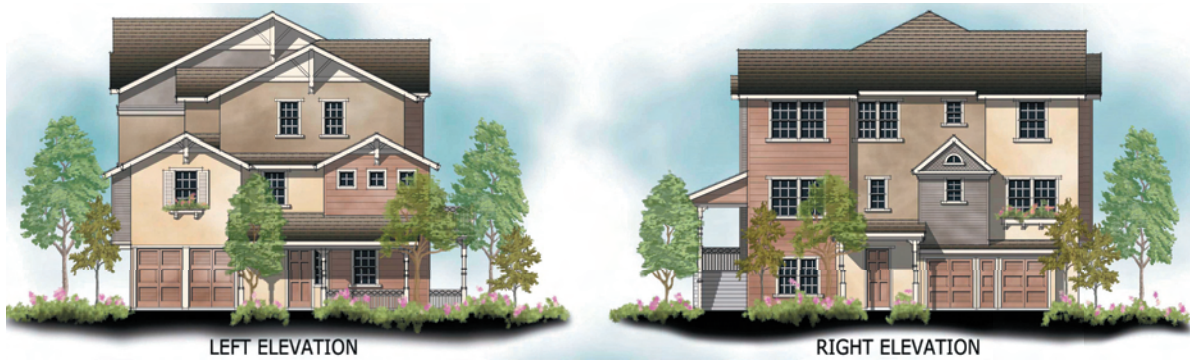

Figure 3.D.57: Sample Residential Building Side Elevation (Northern Neighborhood)

### 3.1.2.A Entry Orientation Guidelines

#### **Mariner's Cove Residential Neighborhood**

1. The entries of all residential buildings should either orient towards the adjacent street or to a landscaped paseo or garden court.
2. The end units of the townhome buildings should have an entry either out onto an at-grade patio or a stoop that lead up to a porch.
3. All other units should have entries associated with a raised porch or stoop that face the street or landscaped paseo or garden court.
4. Main entries may not face the private court roads, which are primarily intended to provide vehicular access to garages integrated into the rear façade of buildings.
5. All entries should be designed to be easily located and be configured to maximize the functionality of internal landscaped paseos, garden courts and private open space.

#### **Waterfront Retail**

1. Retail Building at Corner of Harbor Way and Mare Island Way: It is strongly encouraged to provide a second entry (or entries) to retail space(s) in the building that orient toward Mare Island Way. This will activate the building frontage along the street and provide more direct access for pedestrians approaching from residential areas across Mare Island Way.
2. Retail Building at Harbor Way North of Harbor Master Building: The main entry to this building should be located at its southeastern corner. In this location the entrance can conveniently serve and address both Harbor Way and the parking lot associated with the building.
3. Restaurant Building at Promenade: The main entry to the restaurant should be located at the northeast corner of the building and be clearly visible from both the parking lot entry on Harbor Way, the adjacent Promenade Park, and the Waterfront Promenade.

### 3.1.3 Visibility of Ground Floor Activity in Retail Buildings

Visibility of ground floor activity is important within the Northern Waterfront where retail and restaurant buildings are adjacent to public open spaces and streets. A high level of visibility between the public and private realms will encourage a dynamic environment and afford a greater sense of security during the day and in the evening.

1. Retail Building at Corner of Harbor Way and Mare Island Way: While the building will be primarily accessed and therefore viewed from the parking lot side, it is important that the building maintain a visual relationship to Mare Island Way. In addition to a façade dominated by clear windows facing the parking lot along its longitudinal façade, a minimum of 60% of clear windows should be integrated into the façade facing Mare Island Way.
2. Retail Building at Harbor Way North of Harbor Master Building: Although both the eastern and southern frontages are considered to be the building's primary frontages and should be dominated by display windows, the pedestrian connection along the northwestern façade should also be dominated by clear windows between its mid-point and the corner of the building at Harbor Way, to establish a visual relationship between activities inside the building and the activity along this important pedestrian connection. If the future floor plan requires that more than 50% of the northwestern building frontage consist of a blank wall, should it become the building's service area, the building's façade should be screened from view with trees, tall shrubs, vines and/or other vertical elements. In order to support pedestrian activity along Harbor Way, a minimum of 50% of clear windows should be integrated into the façade facing this street.
3. Restaurant Building at Promenade: All façades facing the restaurant's outdoor patios and the Waterfront Promenade should be dominated by clear windows and french doors (See figure 3.D.58). This will reinforce the critical spatial and visual relationship between these areas and the activities inside of the proposed building. Similarly, clear windows should be provided along the primary frontage of the building toward the parking lot. However, views from these windows into the parking lot should be screened by a landscape buffer located between the edge of the sidewalk and adjacent parking stalls.



Figure 3.D.58: Restaurant with French Doors to Dining Area





Figure 3.D.59: A sidewalk is buffered from an adjacent parking lot by an attractively landscaped wall and overhead trellis.



Figure 3.D.60: A hedge buffers a sidewalk from adjacent parked cars. In the evening, the hedge can prevent headlights from shining on pedestrians.

### 3.1.4 Off-Street Parking Areas

All of the sub-areas of the Northern Waterfront District will have some areas of surface off-street parking. In the Mariner’s Cove residential neighborhood parking for residents will be provided in parking garages for each unit with visitor parking provided both on-street and in small surface parking lots typically at the end of the cul-de-sac streets.

Due to the limited extent of additional planned retail uses in the Northern Waterfront area and the presence of several existing surface parking lots, future parking will occur in surface parking lots rather than structured parking facilities. It is critical to achieving the desired overall character of the Northern Waterfront District that such parking lots are well buffered from residences on the other side of Harbor Way and Mare Island Way, and adjacent open spaces. In addition, most visitors to the retail buildings will arrive in one of the parking lots. It is therefore important to provide high quality pedestrian circulation within the parking area and to the buildings. Finally, because of the large paved areas in surface parking lots, they can negatively impact the microclimate in their surroundings and create large amounts of stormwater runoff. These negative impacts can be partially mitigated by incorporating landscape areas into the parking lot design. The following Guidelines, which supplement those in Section III.A.2.2.5 *Off-Street Parking and Drop-off Areas*, address how this can be achieved.

#### Surface Parking Design – General Guidelines

Parking screening and landscaping is required to provide both a spatial and visual buffer for pedestrians walking on sidewalks, paths, and trails adjacent to a surface parking area and to provide an area that helps to counter-balance the negative impacts of large impervious surfaces. In addition, buffers protect pedestrians from car headlights in the evening and create a more pleasant walking environment to and within Waterfront places.

1. Buffers may consist of a combination of trees, shrubs, vines, low walls, and landscape structures that create a visual and physical separation, and create an attractive frontage onto sidewalks, parks and other adjacent areas.
2. The landscaped buffer should be located between the surface parking lot and adjacent sidewalks, paths, and



trails. The landscape buffer should be a minimum of 6 feet wide if a hedge is used and 10 feet wide if trees and shrubs are used. Where widths are constrained, less than 5 feet in width, a low wall may be used in place of shrubs and hedges. Greater separation and articulation may be achieved with a visually permeable landscape structure such as a trellis.

3. Shrubs, hedges and low walls should not be more than 3-feet 6-inches tall. The use of landscape structures, such as trellises or arbors, is encouraged. The height of any such structures should not exceed 6 feet tall. In cases where this is required by topography, their height may be increased to 8 feet. As the screening of parking should be balanced with the need for visual surveillance of parking areas for security purposes, any portion of a landscape structure above 3-feet 6-inches in height should be largely open to views (Figures 3.D.59 and 3.D.60).
4. If a wall is used, vines or other landscaping should be used to soften the appearance of the wall from the street.
5. Buffers should be protected from car bumpers and fenders with wheel stops or a 6-inch curb. If a 6-inch curb is used, low ground covers should fill the area beyond the back-of-curb. (Figure 3.D.61)
6. Parking lots greater than 24 stalls (approximately one quarter acre) should provide a tree canopy that will cover 50% of the lot at the time of the trees' maturity (approximately 10 years). Spacing of trees will depend upon the species and their growing habits.
7. To effectively achieve this coverage, trees should be planted "orchard style" (i.e., evenly spaced throughout the parking lot; See Figure 3.D.62).
8. Additional landscaping within the interior of parking lots should comprise a minimum of 15% of the total net parking area exclusive of the perimeter planting strip used for screening purposes.
9. Landscape elements, such as trees, plants and structures, within a parking lot and along pedestrian pathways should be utilized to reduce the perceived size of the lot and create a more pleasant microclimate and walking environment for pedestrians (Figure 3.D.63).

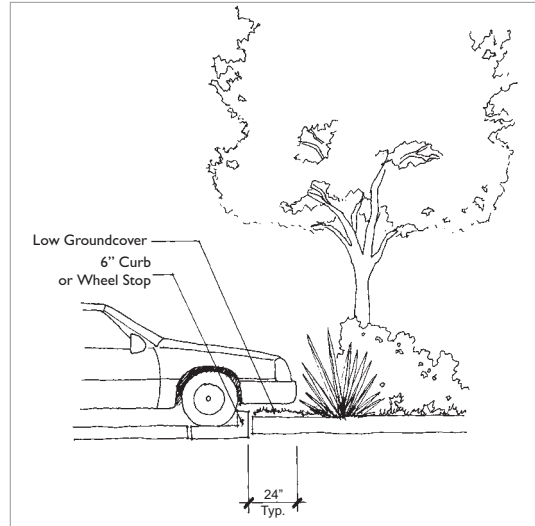

Figure 3.D.61: Wheelstops and low-growing groundcovers keep car overhangs from destroying landscaping within parking lots.



Figure 3.D.62: An orchard configuration maximizes shade for parked cars.



Figure 3.D.63: Landscaping can break up large asphalt areas within parking lots.



Figure 3.D.64: Pedestrian Access at Waterfront Retail (S.A. 2006)



Figure 3.D.65: Example of Swale with Ornamental Planting



Figure 3.D.66: Example of Grassy Swale

10. The number of driveways from individual parking lots to Harbor Way should be limited to one per lot.
11. Where pedestrian connections through parking to the waterfront occur, a raised crossing should be used to elevate the pedestrian crossing at a driveway, to the level of the sidewalk or walkway it is associated with. Special paving should continue the path across the crossing and communicate clearly that cars are crossing a pedestrian path. The elevated crossing can also act as a traffic-calming device within the parking lots. Additionally, a stop sign should be located at this crossing. At a minimum, such instances should occur adjacent to the retail building North of the Harbor Master Building to provide a continuous pedestrian connection from the Harbor Way crosswalk to the waterfront along the northwestern façade of the building and at the drive aisles north of the existing restaurant (currently known as Zio Fraedo's) where they meet the driveway to Harbor Way.
12. The path along the retail building North of the Harbor Master Building should be buffered by a minimum 7-foot wide landscaped area adjacent to the building (See *Section III.D.3.1.1.A Building Setbacks* and *Section III.D.3.1.3 Visibility of Ground Floor Activity in Retail Buildings* for additional Guidelines for this area). As the path extends through the parking lot towards the Promenade the landscaped buffer may be reduced to a minimum 5-foot width due to the constrained proportions of the surface parking lot associated with the retail building (See Figure 3.D.64).
13. Consideration should be given to the use of swales within parking lots to reduce peak stormwater run-off and to treat the water quality of the run-off (Figures 3.D.65 and 3.D.66).

### Surface Parking Design – Paths Along Edges of Parks

Particular care in implementing the above Guidelines should be taken where pedestrian paths provide connections between Harbor Way and the Waterfront Promenade, north and south of the proposed Promenade Park. These paths represent the main connection between the residential areas of Mariner's Cove and the Promenade and will be used by large numbers of pedestrians. High standards for landscape materials and buffering widths should therefore be applied to the landscape buffers between the adjacent parking lots and the paths (3.D.67).

1. Buffer widths between the parks and adjacent parking areas should be a minimum of 10 feet wide. A double row of trees should be provided, with one row planted in the buffer area and the other on the park-side of the path.
2. At the Harbor Way end of the buffer and path, in Promenade Park where it connects to the restaurant building a landscape feature or structure should be provided that adds a visual emphasis to this important public pathway connection.

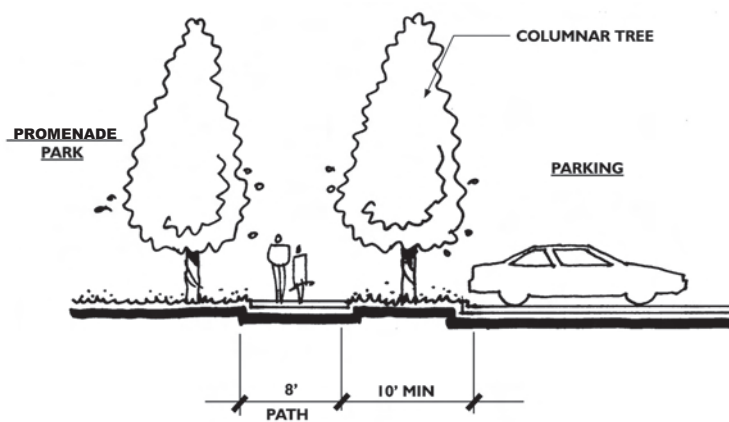

Figure 3.D.67: Cross Section of Buffer Between Parking and Path Along the Edge of Promenade Park

### 3.1.5 Off-Street Loading and Service Access

Where buildings do not form a continuous frontage and particularly where side and rear building façades are exposed to views from multiple vantage points in the surrounding area, it is important that off-street loading and service areas be well sited within the overall site plan and well integrated into the overall architecture of a given retail building. The conditions around the retail buildings in the Northern Waterfront require such treatments. In addition to the Guidelines that are outlined in *Section III.A.2.2.6 Off-Street Loading and Service Access*, the following Guidelines are applicable in the Northern Waterfront District.

1. Appropriate screening strategies include evergreen shrubs and trees, vine-covered walls or fences, and trellises.
2. Planting and overhead features such as trellises and arbors should accompany hardscape features such as curbs and low walls which are used to define the boundary between loading and off-street parking circulation.
3. Retail Building at the corner of Harbor Way and Mare Island Way: Loading and service areas should be consolidated and located at the southwestern building edge facing the parking lot.
4. Retail Building at Harbor Way North of Harbor Master Building: Loading and service areas should be consolidated and located at the western or southern building edge.
5. Restaurant Building at Promenade: Loading and service areas should be consolidated and located at the southern building edge.



## 3.2 Human Scale and Building Contribution to the Public Realm

### *Mariner's Cove Residential Neighborhood*

Variety in building forms and the use of architectural detail elements provide diversity and visual interest to the neighborhood and can be used to create a desirable human scale. The following elements should be incorporated into the design of residential structures:

1. Porches or enhanced entries should be used to articulate each home's primary entry (Figure 3.D.68).
2. Residential structures should orient to the street with front façades that are generally parallel to the street.
3. Projections and recesses should be used to provide shadow and depth.



*Figure 3.D.68: Example of Entry Porches that Enhance and Articulate Individual Building Entries*

### *Waterfront Retail*

Massing, scale, and form of the retail buildings along Harbor Way should respond to the direct relationship of these buildings to adjacent open spaces and the Promenade in this part of the Waterfront. Because of their free-standing locations within the overall site plan of the Northern Waterfront, it is important that these buildings be designed to be aesthetically and architecturally pleasing “on all four sides.” It is also critical that the buildings be conveniently approachable for pedestrians and bicyclists using the many trails and paths in the open spaces in the Northern Waterfront.

#### **3.2.1 Building Form**

The Northern Waterfront District is currently a largely vacant site with the exception of a few buildings along the Waterfront. The building form of these existing buildings is inconsistent and therefore does not provide a sufficient basis for informing the building form of the proposed retail buildings. It is of importance to ensure that the new buildings integrate well with the overall scale of residential development in the area as well as with the existing and proposed parks.





Figure 3.D.69: Sample Elevation Illustrating Residential Building Massing (Southern Neighborhood)

### 3.2.1.A Scale of Building Massing and Height Guidelines

#### **Mariner’s Cove Residential Neighborhood**

In keeping with a pedestrian-oriented community, the scale of buildings should be broken down through the use of varied building massing and forms. Furthermore, both horizontal and vertical offsets help to minimize expansive, uninterrupted wall planes, and are encouraged in the design of the residential buildings (See Figure 3.D.54). Height articulating elements include:

1. Shed roof forms;
2. Second and third story dormers or pop-outs;
3. Multiple plate heights; and,
4. Material and color changes.

#### **Waterfront Retail**

As per the PDMP height standards for the area, retail buildings may be up to 25 feet high. This limit will ensure that the commercial buildings will be smaller in height compared to the residential development (with allowable heights of up to 45 feet) and similar in height to the existing marina-related buildings. This relationship in height will help underscore the intended overall residential and marina-related character of the Northern Waterfront. Similarly, a building’s massing should support the goal of integration with existing and proposed development as well as adjacent parking areas and surrounding open spaces.

1. All retail buildings in the Northern Waterfront should be one-story structures whose scale of building massing is compatible with that of the future residential buildings east of Harbor Way, existing marina-related buildings and with the landscape elements in adjacent existing and future open spaces and parks.



Figure 3.D.70: Sample of a Residential Building Elevation (Northern Neighborhood)

### 3.2.1.B Variations In Building Façade

#### **Mariner's Cove Residential Neighborhood**

In response to the local architectural styles found within the neighborhoods of Vallejo, the architectural design concept for this community is based on maintaining a traditional design, to fit into the context of the surrounding neighborhoods. In order to achieve this, architectural styles and components that complement traditional architecture were selected.

The potential architectural styles selected for this community are a blend of Craftsman and Victorian Traditional (See Figures 3.D.69 and 3.D.70). Elements of these architectural styles focus on human scale details, thus enhancing the pedestrian-friendly character of the neighborhood. Such enhancements include:

- Building projections and recesses;
- Multiple plate heights;
- Front porches;
- Enhanced entries; and
- A mix of materials and textures.

Architectural detailing includes the integration of elements such as:

- Wood Railings;
- Balconies;
- Brackets;
- Outlookers (Elements similar to rafter tails that project out from the gable end of a roof, see Figure 3.D.71);
- Enhanced windows sills; and
- Shutters.

Together, the combination of design features enliven the street and promote the friendly interaction of neighbors.

### **Waterfront Retail**

Similar to the scale of building massing, variations in the design of building façades, such as bays, recesses, overhanging eaves, etc., should be used to create human-scale buildings that integrate well with adjacent open spaces and provide visual interest to their visitors.

1. Buildings with a frontage greater than 30 feet should make use of bays, recesses, overhangs, and other massing elements to create a human-scaled character to the building. The use of changes in plane as small as 6 to 18 inches in depth can be used in combination with architectural detailing, materials, and color to satisfy this Guideline.

#### *3.2.1.C Corners and Landmark Features*

### **Waterfront Retail**

The northeastern corner of Harbor Way at Mare Island Way is the anchor intersection of the Northern Waterfront and acts as a gateway to this District. In contrast to the Central Waterfront, where gateways are created or enhanced by buildings, the gateway at the Harbor Way entry will consist of landscaping that is enhanced by a landscape structure or feature element. This approach is in keeping with the landscaped character of the surrounding neighborhoods and River Park to the north. The Guidelines for the landscape treatment of the entry to the Northern Waterfront at Harbor Way are provided in *Section III.D.2.4.2 Secondary Gateways* of the Northern Waterfront Chapter.

1. Scale and façade articulation of the corner retail building should be designed to further enhance and relate to the future gateway design.

### 3.2.1.D Rooflines and Roof Form

#### **Mariner's Cove Residential Neighborhood**

Similar to building form, roof form and slope are also important design elements in creating the Craftsman and Victorian style that is potentially desired for the neighborhood.

1. Roof treatments should be consistent with the architectural style of the dwelling:
  - Craftsman Style: low-pitched gable roofs should be the primary roof forms used; generally with extended eaves with wooden brackets and outlookers.
  - Victorian Style: front-to-back gable roofs should be the primary roof forms used with steep-pitched side-to-side gable roof forms used on dormers and pop-outs as secondary roof forms.
2. Variety of roof design and treatment is encouraged to provide visual interest to the neighborhood, including the use of gable, cross-gable, hip, or a combination of these roof forms.

#### **Waterfront Retail**

The retail buildings of the Northern Waterfront are visually prominent from the Waterfront Promenade and Parks, and from elevated portions of surrounding neighborhoods located to the east. The profile and form of building rooflines should be sensitively integrated into the character of the surrounding open spaces and be designed to minimize impacts on distant views of the Mare Island Strait and Mare Island.

1. Retail Building at Corner of Harbor Way and Mare Island Way and Retail Building at Harbor Way North of Harbor Master Building: Low-profile, sloped roofs with eaves are recommended for these buildings. Mansard roofs are acceptable if these are well integrated into the overall design of the building and are needed to adequately buffer mechanical equipment.
2. Restaurant Building at Promenade: Sloped roofs with eaves are recommended for this signature building. Mansard roofs are strongly discouraged for this highly visible building.



Figure 3.D.71: Example of Craftsman Style Roof



Figure 3.D.72: Example of Victorian Style Roof

### 3.2.2 Building Articulation

#### Waterfront Retail

Articulation of buildings is important whenever buildings are located in an area with high-levels of pedestrian activity. This is particularly true for buildings along the Waterfront Promenade. These buildings should provide a level of architectural detailing that responds to a human scale in order to create an environment that will be attractive, interesting, and inviting (For additional Guidelines applicable to all buildings see *Section III. A.2.3.2 Building Articulation*).

#### 3.2.2.A Architectural Detailing – Scale and Ornamentation

#### Building Materials and Finishes

#### Mariner’s Cove Residential Neighborhood

**Building materials and color** are important elements to the visual quality of homes within the neighborhood.

1. Building materials (including accent materials, roof materials, and paint colors) should be consistent with the architectural style of the residence. Such materials include the use of:
  - Stucco,
  - Wood or simulated wood siding, and
  - Wood or simulated wood shingle.
2. The use of all surface treatments or materials should be an integral part of the design, and not merely applied.
  - All materials should wrap columns, porches, or balconies in their entirety.
  - Material changes should occur at inside corners or other meaningful locations, such as a change in plane, a bay, door or window frame, or other appropriate architectural feature. Materials applied to any elevation should turn the outside corner of the building a minimum of 3 feet before terminating.
3. The color palette should be selected with the design objectives of avoiding monotony, providing a variety of colorful schemes, and promoting visual diversity.



Furthermore, the color palette should be chosen in keeping with the traditional architectural theme of the neighborhood.

**Roof materials** should be compatible with the architectural style of the residence and should have a matte finish to minimize glare.

1. Permitted Roof Materials
  - Clay or Concrete Flat Tiles
  - Clay or Concrete Shakes
  - Architectural Grade Composition Shingles
2. Prohibited Materials
  - Wood Shake
  - Rolled roofing material

### ***Waterfront Retail***

1. Material selection is particularly critical for the restaurant building and should contribute to creating a signature building for the Waterfront Promenade. Furthermore all exterior building materials should be of a grade that is designed to withstand the harsh conditions of a waterfront location and convey a sense of durability.

### ***3.2.3 Transition from Public Realm to Interior Space***

#### ***Mariner's Cove Residential Neighborhood***

The entry of a residential dwelling should be articulated as a focal point of the building's front elevation. Roof elements, columns, porticos, recesses or projections, windows or other architectural features should be used to accentuate the entryway.

Porches can also be used to help articulate the entry of residential structures. Porches not only provide pedestrian scale elements to the building massing, but also allow for an area for residents to enjoy the outdoor climate and a place to converse with neighbors.

1. When provided, porches should be designed as an integral component of the building's architecture.
2. Porches should have railings and be fully covered in one of the following ways:
  - a. Roof element and tile matching the residence;
  - b. Trellis structure;
  - c. Second floor balcony or overhang.
3. Porches should have a clear depth of at least 5 feet in order to be usable for seating. Porches deeper than this minimum should be provided where feasible.

### **Waterfront Retail**

It is envisioned that the restaurant building and Waterfront Promenade will be located and oriented to have a very close spatial relationship. It is therefore recommended that a transitional space along those edges of the building that face the Promenade be provided in order to express the transition from the public space to the more private interior of the restaurant.

1. Restaurant Building at Promenade: At a minimum, provide porches along all Promenade-facing building façades. This will contribute to the architectural “waterfront” character of the building and provide an outdoor area with some protection from windy or rainy weather as well as glare on sunny days.

Landscaping along the edges of the restaurant’s patio area(s) should enhance the outdoor seating area. It should not be designed to buffer or separate the patio from the adjacent Waterfront Promenade, but rather be used to integrate the two areas.

### **3.2.4 Utilities and Mechanical Equipment**

#### **Mariner’s Cove Residential Neighborhood**

Special care should be made so that mechanical equipment does not detract from the architecture of the primary residence.

1. Mechanical equipment such as air conditioners, heaters, evaporative coolers, television and radio antennas, and other such devices should not be mounted on any roof.
2. Mechanical devices such as exhaust fans, vents and pipes should be painted to match adjacent roof surfaces.
3. Ground mounted air conditioning units must be located behind side yard privacy return walls.

### **Waterfront Retail**

Rooftop utilities on retail buildings in the Northern Waterfront District will be particularly visible from Mare Island Way and residential areas to the east, where with increasing elevation even more of the roof area becomes visible.

1. Carefully screen rooftop utilities from exposure to views from Mare Island Way and elevated residential areas located toward the east.
2. Carefully integrate such screens into the overall architecture of the building and roof design.

### **3.2.5 Signage**

Building signage for the retail and restaurant buildings in the Northern Waterfront should be particularly modest in order to enhance the overall residential and recreational character of the District (Also see *Section III.A.2.3.6 Guidelines for All Districts: Signage*).

1. Restaurant Building at Promenade: Signage for this building should be limited to pedestrian-oriented signs.

### 3.3 Neighborhood Open Space

#### 3.3.1 Mariner's Cove Landscaped Paseos and Garden Courts

The homes within Mariner Cove will face onto tree-lined streets or the internal pathway paseos. The paseos should be configured to create space for neighbors to stop and have informal conversations at the stairway to each home entry. The landscaping along the pathways should be designed to emphasize the “individual” identity of each home.

Intimate outdoor courts should be created at pathway intersections and between building clusters. These spaces should contain informal lawn areas, seating, and special planting to enhance overall community ambiance (See Figures 3.D.73 through 3.D.76).

Where space permits garden courts should be developed, and include amenities such as tot lots, shaded seating respites, and barbeque areas.



Figure 3.D.73: Location of a Proposed Landscaped Paseo



Figure 3.D.74: Example of a Landscaped Paseo



Figure 3.D.75: Sketch Plan of a Proposed Landscaped Paseo

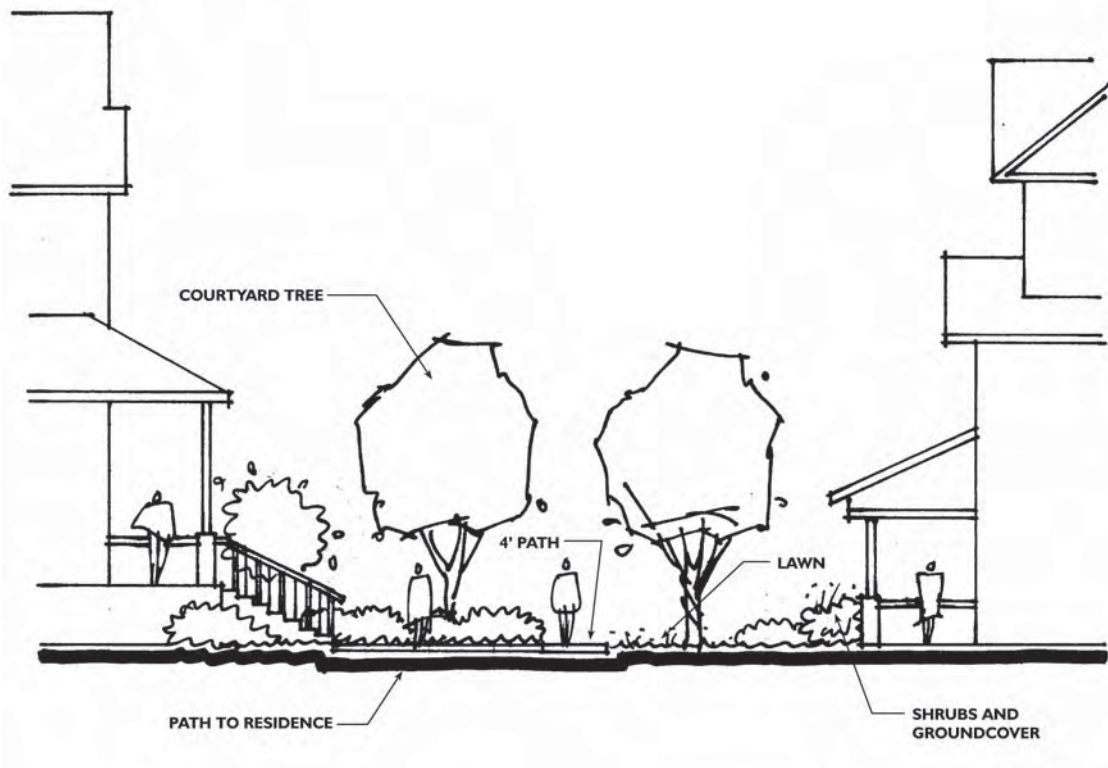

Figure 3.D.76: Illustrative Cross Section through Proposed Landscaped Paseo



This Page Intentionally Left Blank



This Page Intentionally Left Blank

# Acknowledgements

## City Council

*Anthony J. Intintoli, Jr. - Mayor*

*Gerald Davis*

*Tony Pearsall*

*Gerald Davis*

*Gary Cloutier*

*Tom Bantee*

*Herminio Sunga*

*Stephanie Gomes*

## Planning Commission

*Robert McConnell, Chairperson*

*Norm Turley, Vice Chair*

*Gary Salvadori*

*Linda Engelman*

*Gary Morris*

*Gail Manning*

*Charles Legalos*

## City Staff

*Craig Whittom, Assistant City Manager*

*Brian Dolan, Development Services Director*

*Bonnie Robinson-Lipscomb, Senior Community Development Analyst*

*Gary Leach, City Engineer*

*Taner Aksu, City Traffic Engineer*

*Sam Gonzales, Landscape Maintenance District Manager*

*Crystal Odun-Ford, Transportation Superintendent*

*Ann Meredith, Former Development Services Director*

*Al DaSilva, Former Community Development Director*

*Jerry Haag, Contract Planner*

## Callahan/DeSilva Vallejo LLC

*Joseph W. Callahan, Jr., Principal, Callahan Property Company*

*Jim Summers, President, The DeSilva Group*

*Leah Dreger, Manager, The DeSilva Group*

*Tim Collins, Media Coordinator, The DeSilva Group*

## Community Design + Architecture

*Philip Erickson, Principal-in-Charge*

*Sue Chan, Senior Associate*

*Thomas Kronemeyer, Senior Associate*

*Danielle Wong, Urban Designer*

*Kendra Mitchell, Urban Designer*

*Bharat Singh, Urban Designer/Planner*

*Clark Wilson, Associate Principal*

*Janice Lum, Urban Designer*

*Nino Walker, Intern*

*Kyla Burson, Intern*

## Northern Waterfront

Site Plan and Landscape Architecture:

*Gates + Associates, Danville, California*

Parcel A Architecture:

*KTGY Group, Inc., Irvine, California*

This Page Intentionally Left Blank